

AZTECK

ASSEMBLY INSTRUCTIONS

4.00 x 5.60 x 1.40 metre

Above-ground pool

Mixed Model



AZTECK THANKS YOU FOR YOUR PURCHASE AND
HOPES YOU WILL ENJOY YOUR ASSEMBLY EXPERIENCE

AZTECK MIXED MODEL 4 x 5.60 metre above-ground pool

CONTENTS

Parts list and illustrations	Pages 3-13
General	Pages 14-17
Preparing the ground	Page 18
Preparing the concrete apron	Page 18
Assembling the metal structure	Pages 19-23
Assembling the SKD metal structure + pre-liner elements	Pages 24-29
Installing the liner	Pages 30-33
Filling with water + water system connections	Pages 34-38
Installing composite elements	Pages 39-45
Skimmer Dress finish	Page 46
Installation electrical connection boxes	Page 47
Assembling the outside ladder	Pages 48-51
Last measurements for inspection purposes	Page 52
Safety and maintenance tips	Pages 53-59
Maintenance	Pages 60-63
Warranty and terms	Pages 64-69

Parts list and illustrations

Open all of the boxes and ensure that all of the parts listed below are present. Learn to identify them. Never start the installation work if you have any doubt about the identification of the parts. Do not hesitate to ask your dealer!

Note: Drawings are not to scale. The parts listed below relate only to the pool structure.

ALL OF THE DIMENSIONS SHOWN IN THESE INSTRUCTIONS ARE IN MILLIMETRES

METAL STRUCTURE

Number	Description	Quantity
P40961	7+1 panels 1.50 x 1.40 with skimmer / nozzle cut-out	1
P40203	Panels 1.50 x 1.40	7
P40204	Panel 1.00 x 1.40	4
P40271	Post 90, height: 1.40	2
P40211	45° angle post, height: 1.40m	8
P40530	Corner post, height: 1.40 thickness: 5	6
P40264	HSL 3M12/25 fixing anchor	6
P40690	HSL 3 B M12/25 torque mounting anchor	12
P40628	Adjustment shim	50
P40475	Bag of M8 x 20 screws	
P40499	Bag of M8 x 130 screws	
P39862	Zinc spray 400 ML	1
P36942	Felt 24 M2	1

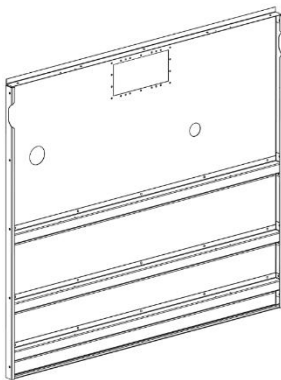

P40961

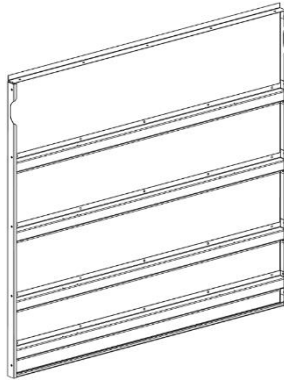

P40203

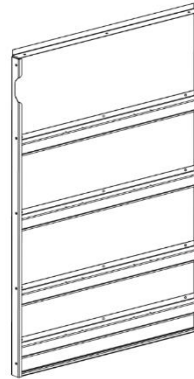

P40204

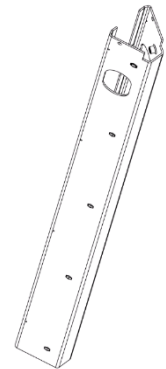

P40211

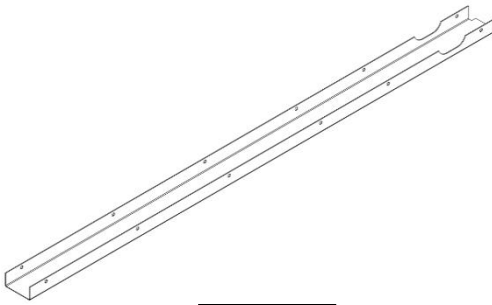

P40271



P36942



P40264



P40690

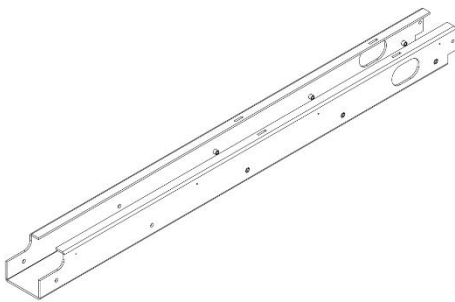

P40530



P39862

M8 x 20 screw

M8 washer

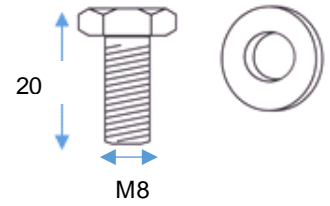

P40475

M8 x 130 screw

M8 washer

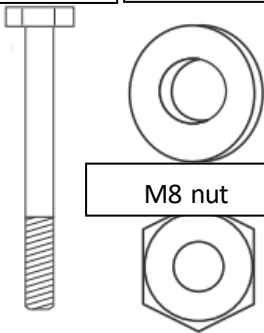

M8 nut

P40499

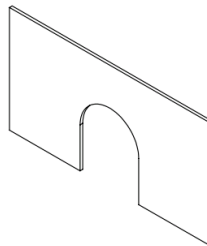

P40628

DETAILS OF COMPOSITE ELEMENTS BY COLOUR

The tables below show the quantities of composite elements depending on the colour configuration that you chose.

For the **Exotic Brown / Teak** configuration

Pool

Number	Description	Quantity
P40245	L932 Teak facing	28
P40242	L1540 Teak facing	49
P40248	L140 Teak facing	14
P40244	L932 Exotic Brown facing	8
P40241	L1540 Exotic Brown facing	14
P40247	L140 Exotic Brown facing	4
P40239	L1357 machined Exotic Brown foot	6
P40236	L1357 Exotic Brown upright	8
P40231	45-45 L100 Exotic Brown pool coping	2
P40230	90-45 L1000 Exotic Brown pool coping	2
P40229	45-90 L1000 Exotic Brown pool coping	2
P40277	45-45 L1500 Exotic Brown pool coping	3
P40278	45-90 L1500 Exotic Brown pool coping	1
P40280	90-45 L1500 Exotic Brown pool coping	1
P40288	90-90 L1500 Exotic Brown pool coping	3
P40447	Cast iron foot painted Brown	6

Skimmer Dress

P40527	SKD machined Teak facing	2
P40254	SD 800 Teak facing	7
P40456	SKD L1375 Exotic Brown pool coping	1
P40250	SD L400 Exotic Brown facing	4
P40251	SD L400 Teak facing	12
P40253	SD L800 Exotic Brown facing	2
P40236	L1357 Exotic Brown upright	2

NOTE: If you opted for a single colour pool, the Teak colour elements are replaced by Exotic Brown colour elements

For the Colorado Brown / Teak configuration

Pool

Number	Description	Quantity
P40245	L932 Teak facing	28
P40242	L1540 Teak facing	49
P40248	L140 Teak facing	14
P40243	L932 Colorado Brown facing	8
P40240	L1540 Colorado Brown facing	14
P40246	L140 Colorado Brown facing	4
P40235	L1357 machined Colorado Brown foot	6
P40232	L1357 Colorado Brown upright	8
P40228	45-45 L100 Colorado Brown pool coping	2
P40227	90-45 L1000 Colorado Brown pool coping	2
P40226	45-90 L1000 Colorado Brown pool coping	2
P40283	45-45 L1500 Colorado Brown pool coping	3
P40284	45-90 L1500 Colorado Brown pool coping	1
P40286	90-45 L1500 Colorado Brown pool coping	1
P40287	90-90 L1500 Colorado Brown pool coping	3
P40447	Cast iron foot painted Brown	6

Skimmer Dress

P40529	SKD machined Teak facing	2
P40254	SD 800 Teak facing	7
P40455	SKD L1375 Colorado Brown pool coping	1
P40249	SD L400 Colorado Brown facing	4
P40251	SD L400 Teak facing	12
P40252	SD L800 Colorado Brown facing	2
P40232	L1357 Colorado Brown upright	2

NOTE: If you opted for a single colour pool, the Teak colour elements are replaced by Colorado Brown colour elements

For the Anthracite Grey / Iroise Grey configuration

Pool

Number	Description	Quantity
P40784	L932 Iroise Grey facing	28
P40783	L1540 Iroise Grey facing	49
P40785	L140 Iroise Grey facing	14
P40778	L932 Anthracite Grey facing	8
P40777	L1540 Anthracite Grey facing	14
P40779	L140 Anthracite Grey facing	4
P40776	L1357 machined Anthracite Grey foot	6
P40773	L1357 Anthracite Grey upright	8
P40755	45-45 L100 Anthracite Grey pool coping	2
P40754	90-45 L1000 Anthracite Grey pool coping	2
P40753	45-90 L1000 Anthracite Grey pool coping	2
P40759	45-45 L1500 Anthracite Grey pool coping	3
P40760	45-90 L1500 Anthracite Grey pool coping	1
P40761	90-45 L1500 Anthracite Grey pool coping	1
P40762	90-90 L1500 Anthracite Grey pool coping	3
P40805	Cast iron foot painted Grey	6

Skimmer Dress

P40788	SKD machined Iroise Grey facing	2
P40787	SD L800 Iroise Grey facing	7
P40767	SKD L1375 Anthracite Grey pool coping	1
P40780	SD L400 Anthracite Grey facing	4
P40786	SD L400 Iroise Grey facing	12
P40781	SD L800 Anthracite Grey facing	2
P40773	L1357 Anthracite Grey upright	2

NOTE: If you opted for a single colour pool, the Iroise Grey colour elements are replaced by Anthracite Grey colour elements

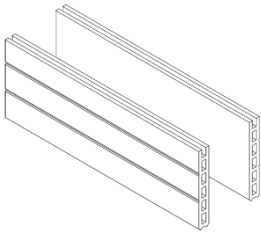

SD 400 Machined facing

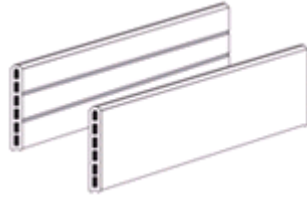

SD 800 facing



SKD 1375 pool coping

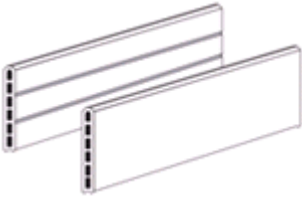

SD 400 facing

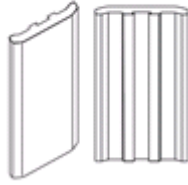

1357 upright

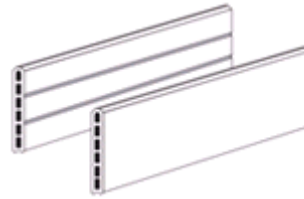

1540 facing

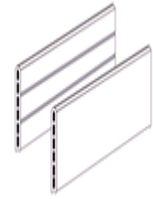

140 facing

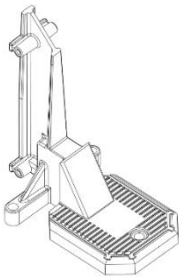

Cast iron foot

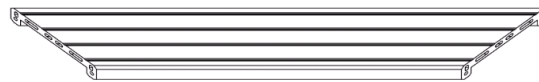

45-45 L 1500 pool coping

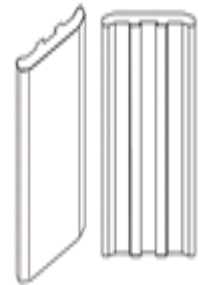

1357 machined upright



45-45 L 100 pool coping



45-90 L 1500 pool coping



90-45 L 1500 pool coping



90-90 L 1500 pool coping



45-90 L 1000 pool coping



90-45 L 1000 pool coping

FINISH

Number	Description	Quantity
P40626	Box of 2 stainless steel AZTECK 3 pool coping covers	7
P40214	Angle flange	8
P40213	Straight flange	6
P40216	Corner panel	8
P40215	Straight panel	6
P40806	WPC upright support	28
P40439	Bag of 3.9 metal screws	
P40497	Bag of M6 x 16 screws	
P20001	Inside pool ladder stainless steel 1.40	1
P20472	Liner hung stop for high liner lock	1
P20481	AZTECK liner lock - 855mm	21

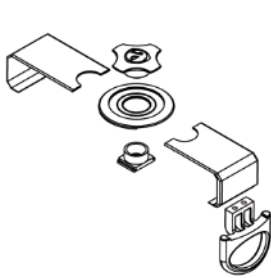

P40626

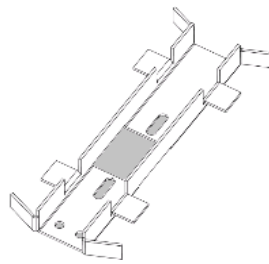

P40214

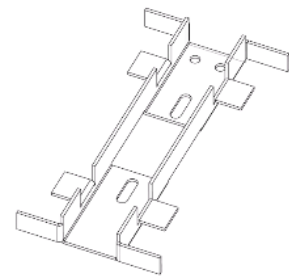

P40213

M6 washer M6 x 16 screw Metal screw 3.9 x 9.5

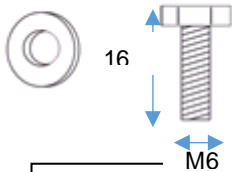

P40497

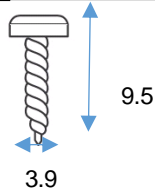

P40439

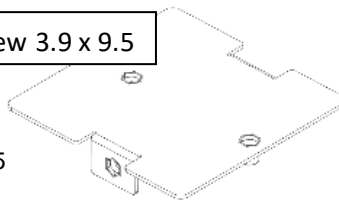

P40215

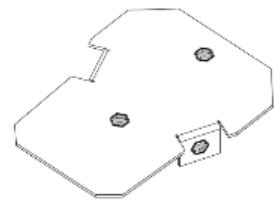

P40216

High liner lock

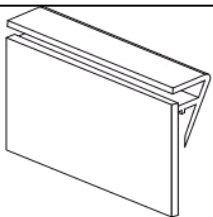

P20481

Line hung stop

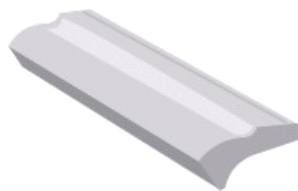

P20472

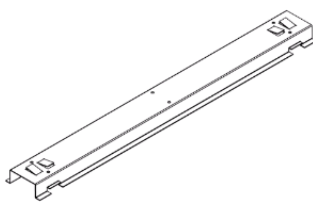

P40806

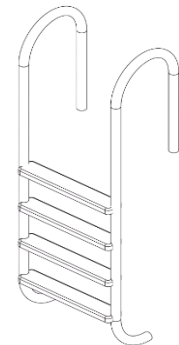

P20001

SKIMMER DRESS

Number	Description	Quantity
P40191	SKD support left	3
P40192	SKD support right	3
P40479	SD nut and bolt kit 1.40	1
P39069	Box of stainless steel SKD parts	1
P20238	SD spacer	1
P40184	Upper cladding WPC SD 1.40	2
P40182	Upper upright WPC SD 1.40	2



M6 washer	M6 x 16 screw	Metal screw 3.9 x 9.5
-----------	---------------	-----------------------

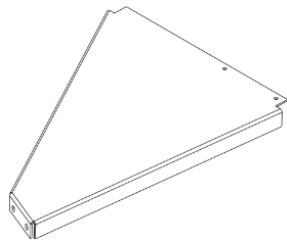

P40191

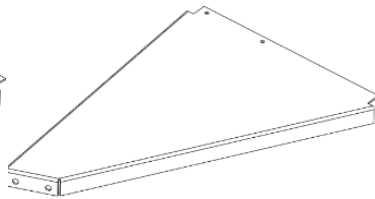

P40192

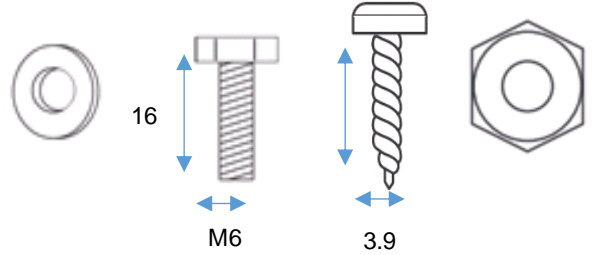

P40479

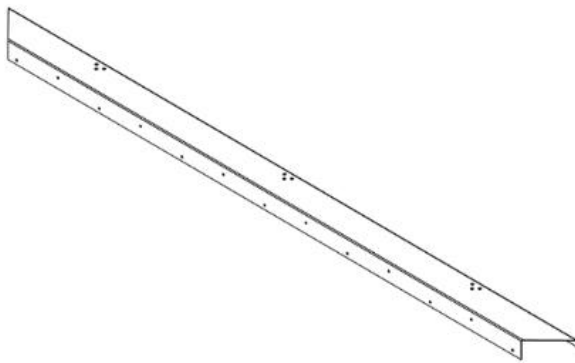

P20238

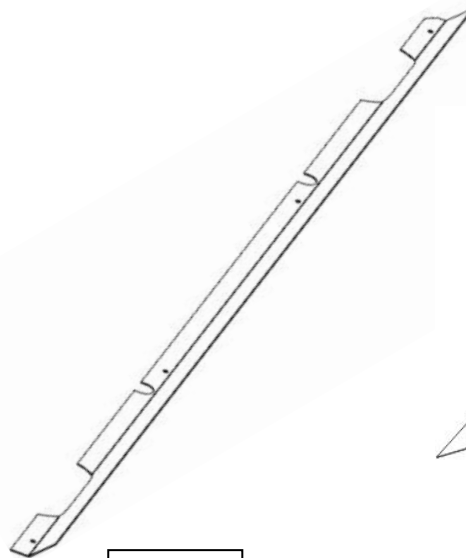

P40184

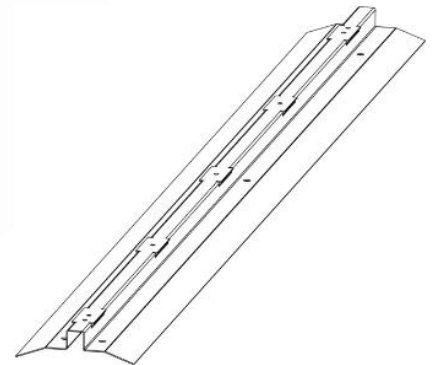

P40182



P39069

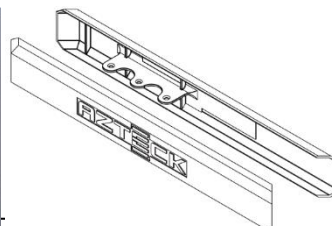

FILTRATION

Cartridge (standard)

Number	Description	Quantity
P20559	Skimmer Weltico 300 HS C5	1
P40547	Box of skimmer/nozzle connectors (2017)*	1
2260162	Aquaplus 6 pump	1
P20619	SD safety electrical box	1
P20571	50 dia. rigid pipe length 1.20m	3
P41056	LED + Filtration programming box	1
P41057	White LED spot kit	1

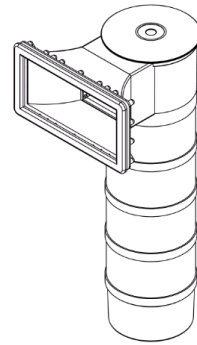

P20559



P20619

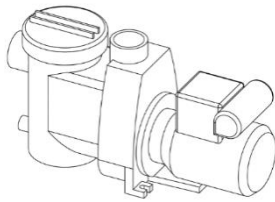

2260162

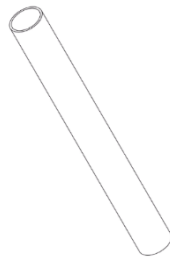

P20571



P41056

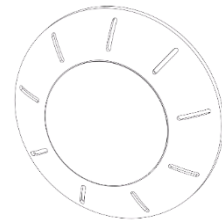

P41057

If you opted for sand filtering (optional)

Number	Description	Quantity
2260002	6 m³/hr sand filtering panel pipe 38mm	1
P39226	D45/25 pipe	1
P39136	25 KG sand bag	1
P41129	Sand filter skimmer kit (AZTECK 7+1)**	1
P41056	LED + filtration box	1
P41057	White LED spot kit	1



P39136



2260002



P39226



P41056

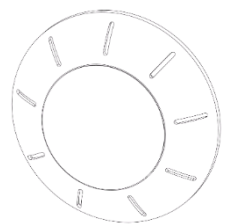

P41057

*CONTENT LIST BOX P40547

Number	Description	Quantity
RLPPP	AZTECK nozzle (v2017)	1
P62125	1/4 turn valve F50 / F50	2
P20103	Mix end 50X63 - 1"1/2	1
P17977	PVC 90° elbow F50/ F50	10
P17375	White Teflon	2
BOUHIV	Winter cap return nozzle AZ	1
P61415	Large seal dbl. skim SM03	1
590000007	Diam 50 connection for Aqua Plus pump to glue	2
P19340	Union connector F50/M1"1/2	3
P18391	PVC glue	2

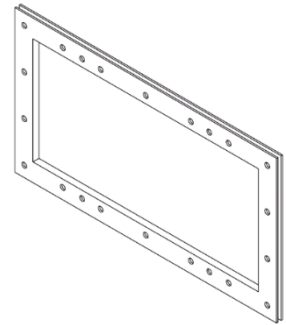

P61415



590000007

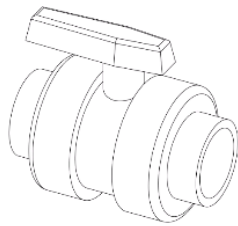

P62125

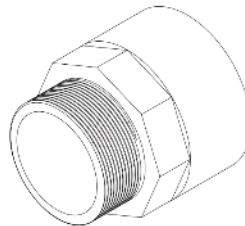

P20103

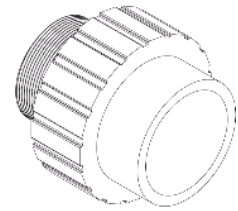

P19340

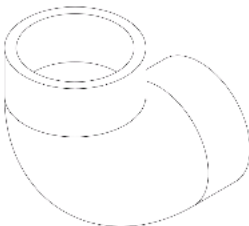

P17977

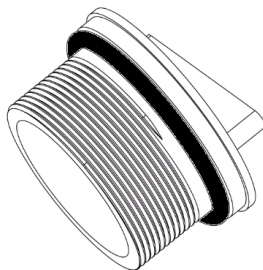

BOUHIV

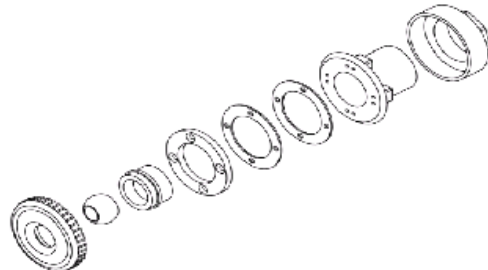

RLPPP

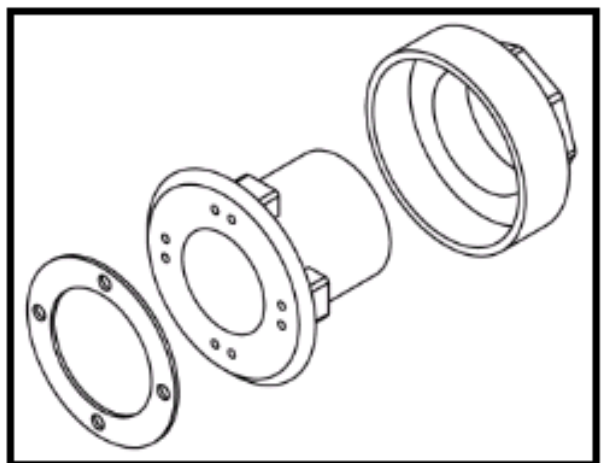
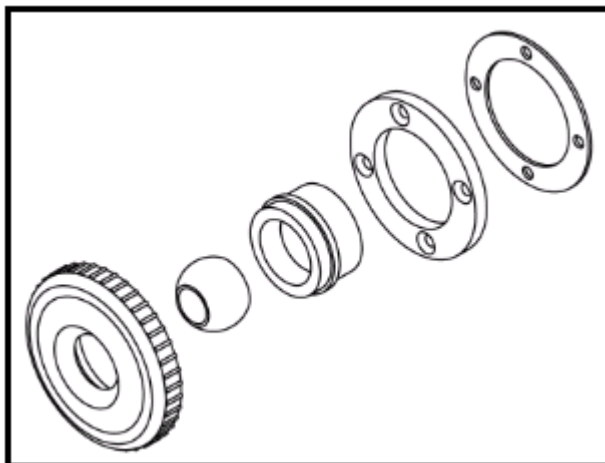

****DETAILS OF THE SAND SKIMMER KIT (P41129)**

Number	Description	Quantity
P20529	Large opening II skimmer 98286	1
P61415	Large seal double skimmer	1
P62125	1/4 turn valve F50 / F50	2
BOUHIV	Winter cap return nozzle AZ	1
P20103	Mix end 50X63 - 1"1/2	1
P17375	White Teflon	1
590000007	Diam 50 connection for Aqua Plus pump to glue	2
P18391	PVC glue	1
RLPPP	AZTECK nozzle (v2017)	1

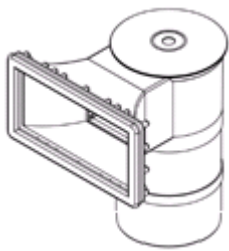

P20529

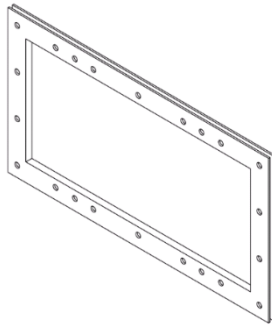

P61415

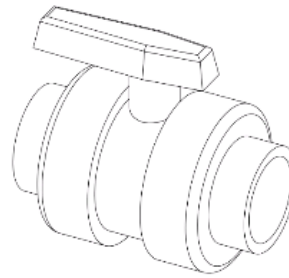

P62125



590000007

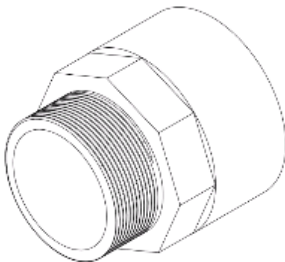

P20103

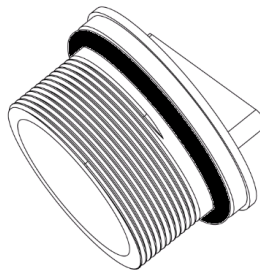

BOUHIV



RLPPP

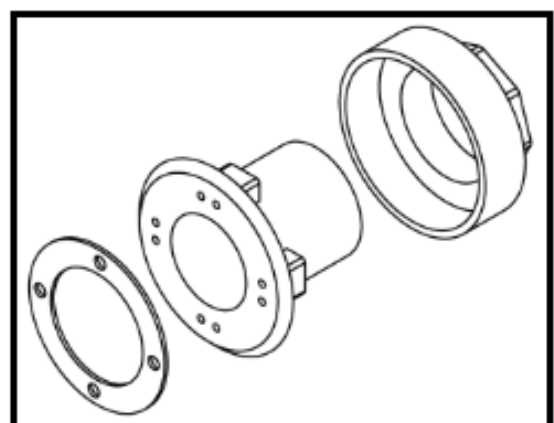
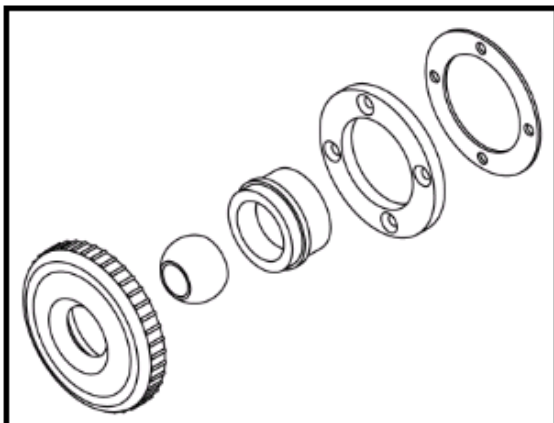

GENERAL

⚠ Caution, your pool contains thousands of litres of water. Poorly prepared ground or an improperly assembled pool may cause major damage.

REMINDER: 1000 litres of water = 1 cubic metre = 1 ton

Legal requirements: Refer to applicable laws covering the installation of pools (refer to your local town hall for information).

Carefully read the safety instructions and apply them.

Do not hesitate to contact our approved distributors for any additional information you may require.

The appearance and the solidity of your pool depend on the care that you take during installation. Your pool comprises a number of components. Before installing your model of pool, examine all of the parts and know how to identify them from the parts list.

1. CHOOSING THE LOCATION

Examine all of the land area available when determining the best location for a pool. The best location is one that offers plenty of space. If you do not have enough flat space available for your pool, then identify the location where the least excavation work is required. Never install any part of your pool in a natural collection area used for water run-off or in an area that may flood. The space around the base of your pool must be level over an area of at least one metre all around the pool.

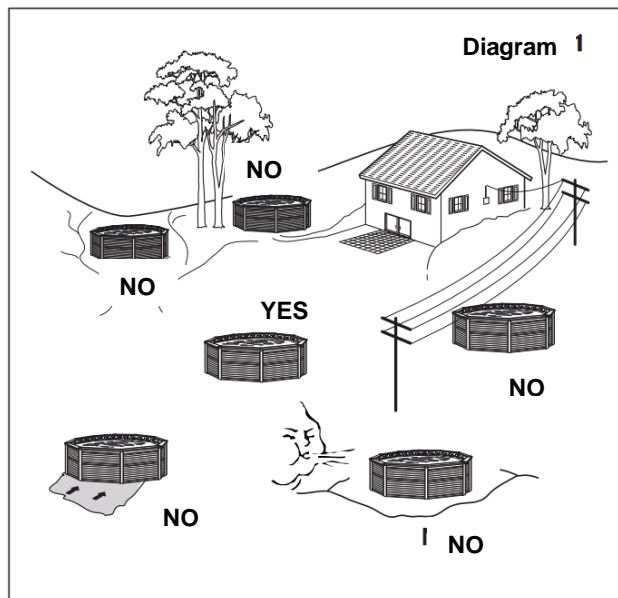

2. GROUND

The ground that your pool rests on must be solid (no backfill), stable, flat, smooth and horizontally level. Levelled ground (without any holes or lumps) is essential or this will cause stresses that may damage your pool.

Very important: Beware of water seepage caused by ground water.

3. UNDERGROUND UTILITIES

Always ensure that no underground utility line (water, gas, electricity, telephone, cables, etc.) run where you wish to locate and install your pool.

4. OVERHEAD ELECTRIC LINES

As a precautionary measure, the pool must not be located directly under overhead electric power lines. In some areas, this is also illegal.

5. TREES

Trees are not always an issue. You should however pay attention to the shadow that they cast and especially to the issues they may cause. The presence of a linden or birch tree should be avoided. This is because these trees will release pollen, flowers or leaves into your pool throughout the year. Trees can also be good neighbours when they serve as a windbreak or screen and belong to persistent foliage varieties.

6. SUNLIGHT

Where there are a number of different sunny locations, prefer those exposed to the morning sun. The morning sun provides far more heat than the sun at the end of the day.

7. WIND

Install your pool away from the prevailing wind. A pool exposed to wind will lose a significant amount of heat due to evaporation. Pool covers (bubble type or winter covers) that are exposed to too much wind may deteriorate prematurely.

⚠ Important: Always install the one or more skimmers facing the prevailing wind preferably widthwise across the pool.

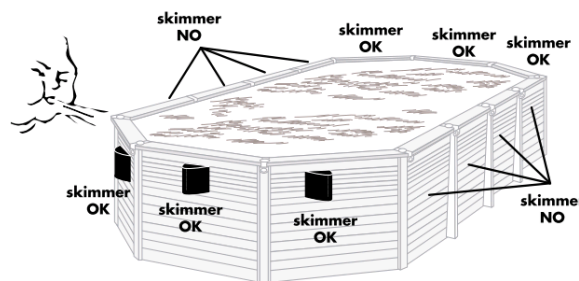

8. PRIVACY

Your pool should be an integral part of your home, an additional room with all of the advantages this can bring. Properly located, a pool should be close to the house and in a fairly private part of the garden, away from neighbour's prying eyes.

9. AN ENVIRONMENT COMBINING WATER AND ELECTRICITY

Remember to provide a water and electricity supply for your filtration system. Do not forget to allow for the ability to drain your pool as part of short term maintenance.

Note: The distance between the pool and the filtering system is **3.5 metres** according to CENELEC HD 384 harmonisation documents. For France the NFC 15-100 standard applies.

 **Use a power outlet fitted with a 30mA ground fault protection device. Check the applicable standards with a specialist.**

10. FULL POOL

Remember that a pool should always remain full whatever the season. Never empty your pool other than for short duration maintenance purposes and if the pool is to be dismantled.

11. APPROVED SAFETY DEVICE

In France, even partially semi-inground pools are required by the law of 3 January 2003 to be fitted with a standardised safety system intended to prevent drowning hazards (fence, alarm, safety cover). Ask your distributor and specialist suppliers of these systems for information to ensure that your chosen equipment fits your project and offers the best safety.

PREPARING THE GROUND

Draw markings on the ground to the stated dimensions. These dimensions will be those of your concrete apron.

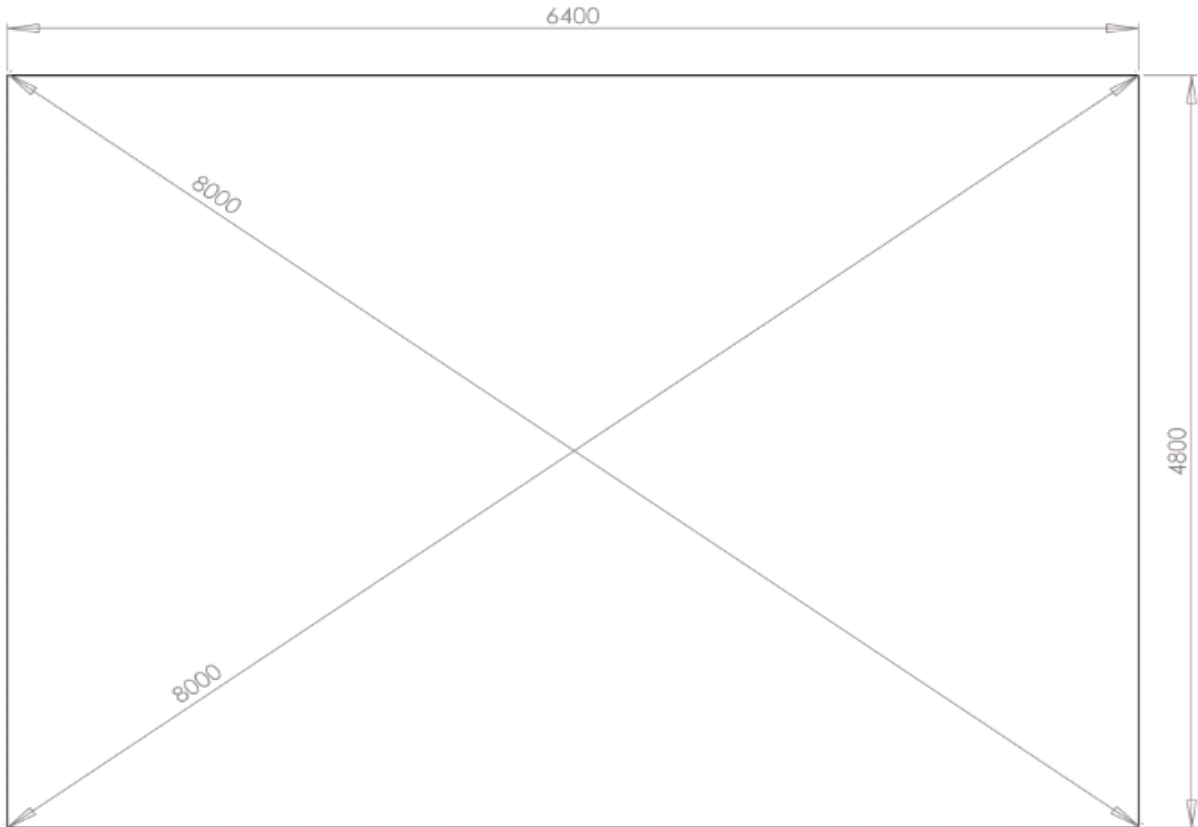

CONCRETE APRON

Refer to specialists like architects, landscapers, masons, pool builders, plumbers, electricians and others, where necessary and have them do the work so that the location and installation work is done in compliance with best practices and in compliance with the applicable standards and regulations in the country and location where the pool is installed.



The concrete apron requires a thickness of at least 17cm with a welded reinforcing mat, CPJ 45 type concrete with a dosage of 350kg/m³ perfectly compressed and vibrated down. Remember that any imperfection in the concrete apron will be visible once the pool is full of water. Check the flatness and perfect execution of the surfacing work.

The effort and care that you take in preparing the foundations may make a significant difference to the life of your pool and its liner.

IMPORTANT: The time required for the slab to set is 3 to 4 weeks. It is impossible to assemble the swimming pool until it has set completely or the slab and pool may deform leading to a warranty exclusion.

ASSEMBLING THE METAL STRUCTURE

1. MARKING ON THE GROUND

⚠ Plan for the positioning of the ladder and skimmer dress in relation to the slab.

Before assembling your metal structure, take a piece of chalk and draw the shape of your pool on the ground, taking care to refer to the measurements provided below (these measurements are the inside pool dimensions).

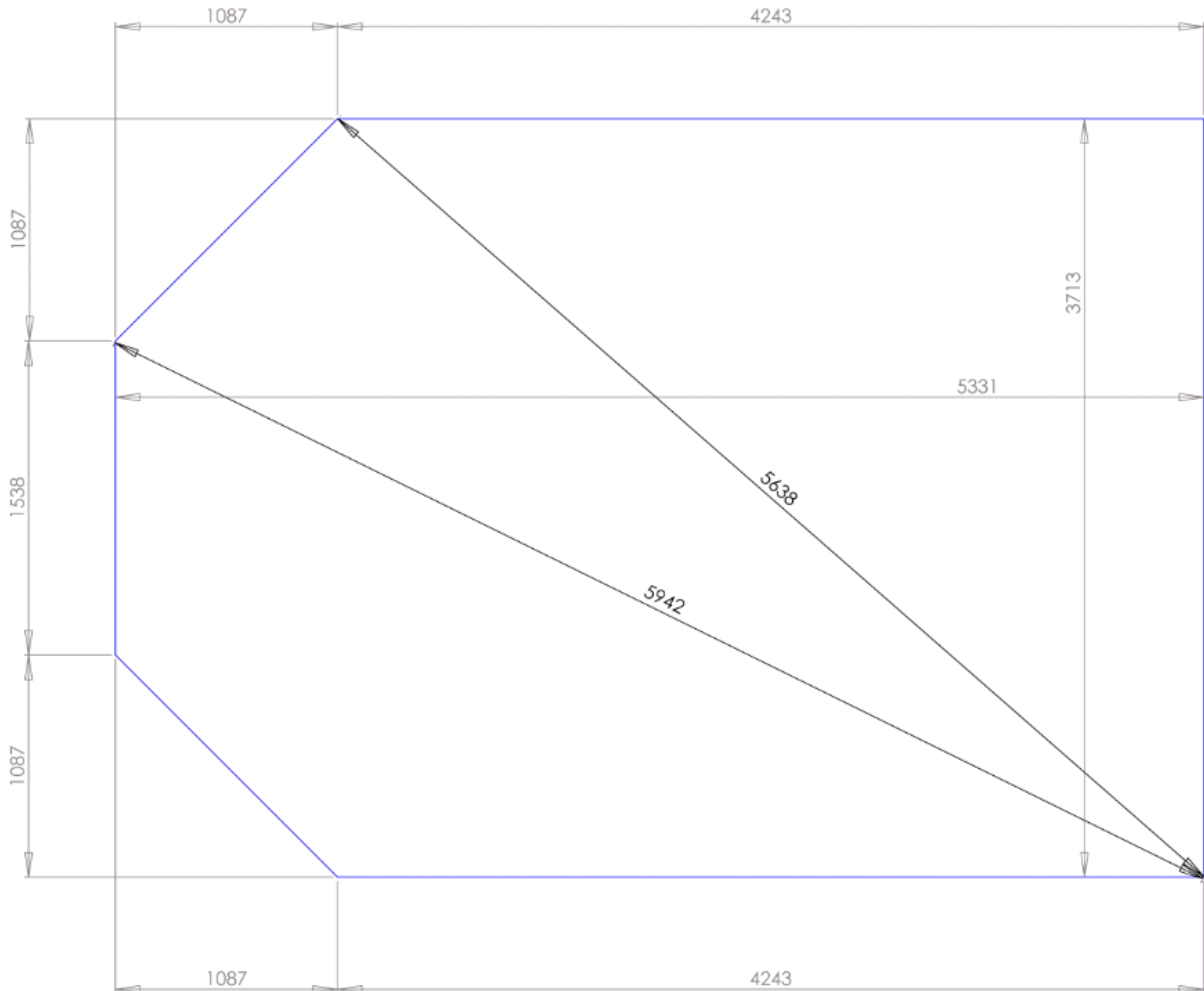

Remember: Take care to keep children away from the "works" for the entire duration of the installation work required to complete your pool. At least three people wearing gloves are required to perform the assembly work on a fine weather, wind-free day.

Tools required to assemble the structure

- | | |
|---|---------------------------------|
| - Gloves (especially for the cast iron feet) | - Drill with an 18 mm drill bit |
| - Wrench or impact wrench with a 13 mm socket | - Wrench with a 19 mm socket |
| - Wrench or impact wrench with a 10 mm socket | - Wrench with a 24 mm socket |

2. PANEL AND POST LAYOUT

Once the pool is drawn, layout the panels, cast iron feet and the posts on the ground along the lines drawn.

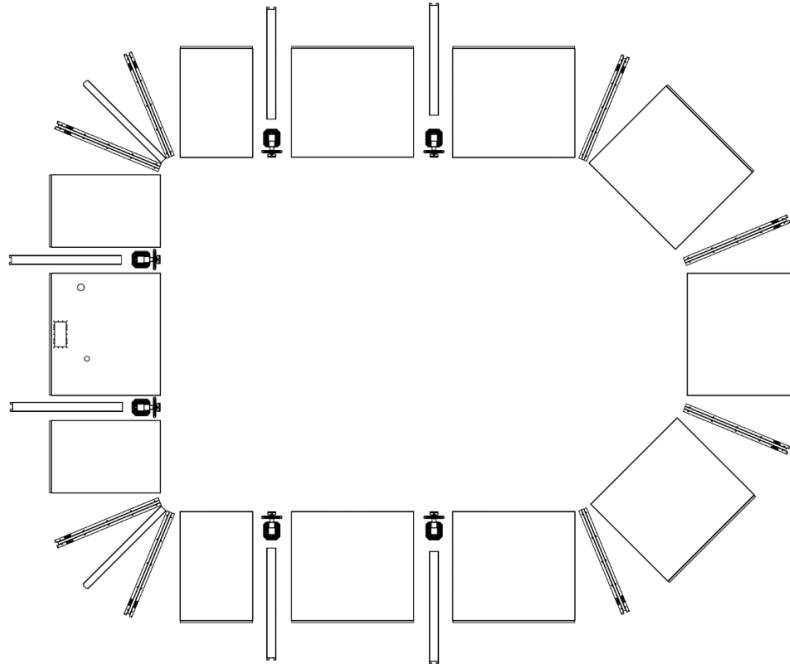

Assembling a curved part

Take a first panel and a post and assemble them with the M8 x 20 bolts and washers, then continue this operation until the entire panel-post structure is assembled.

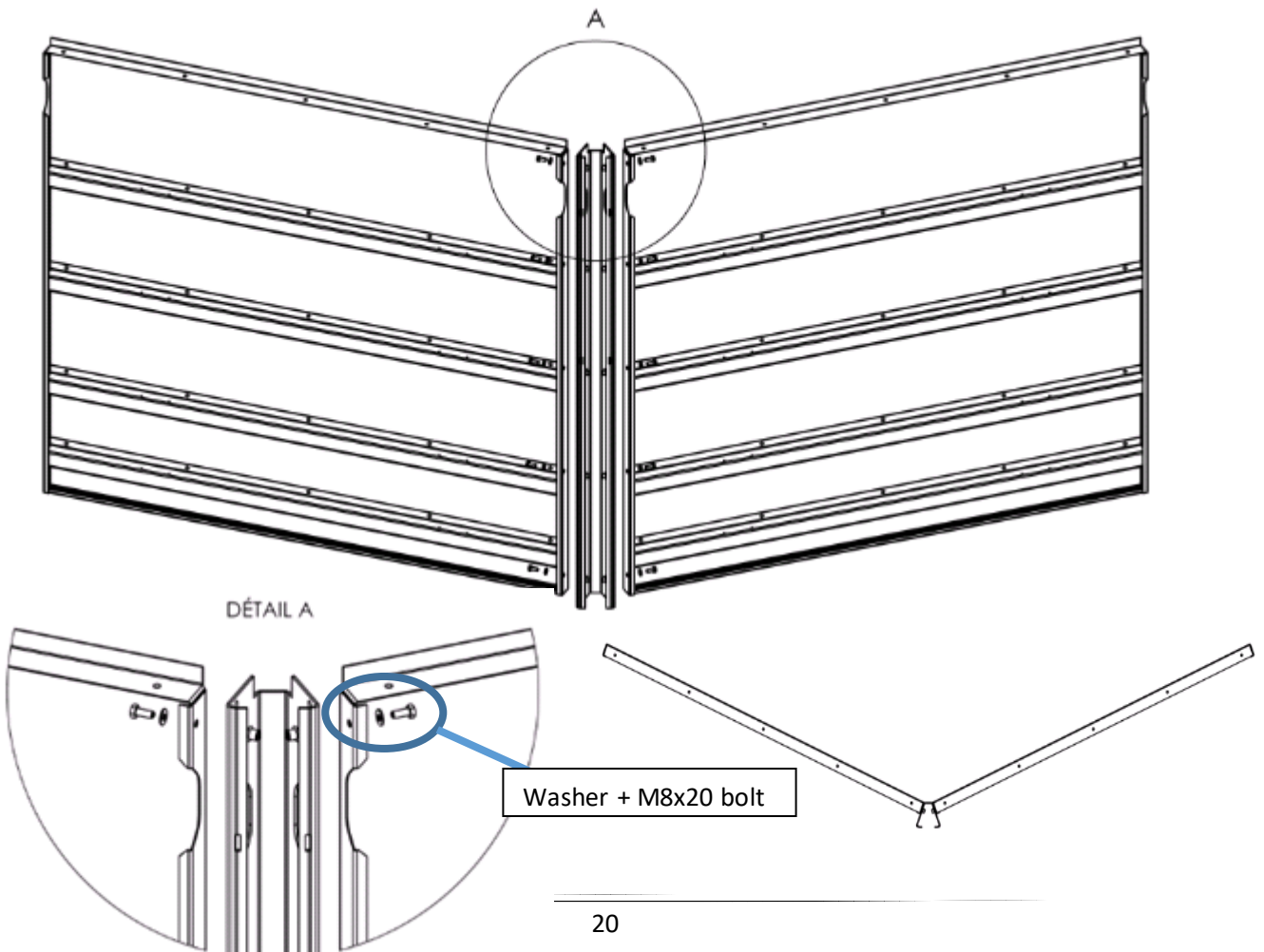

Assembling a straight part

Start by inserting a post into a cast iron foot.

Attach the cast iron foot/upright/panel assembly using M8 x 130 bolts and washers and nuts (Detailed view D).

Attach the upright/panel using M8 x 20 bolts and washers (Detailed view C).

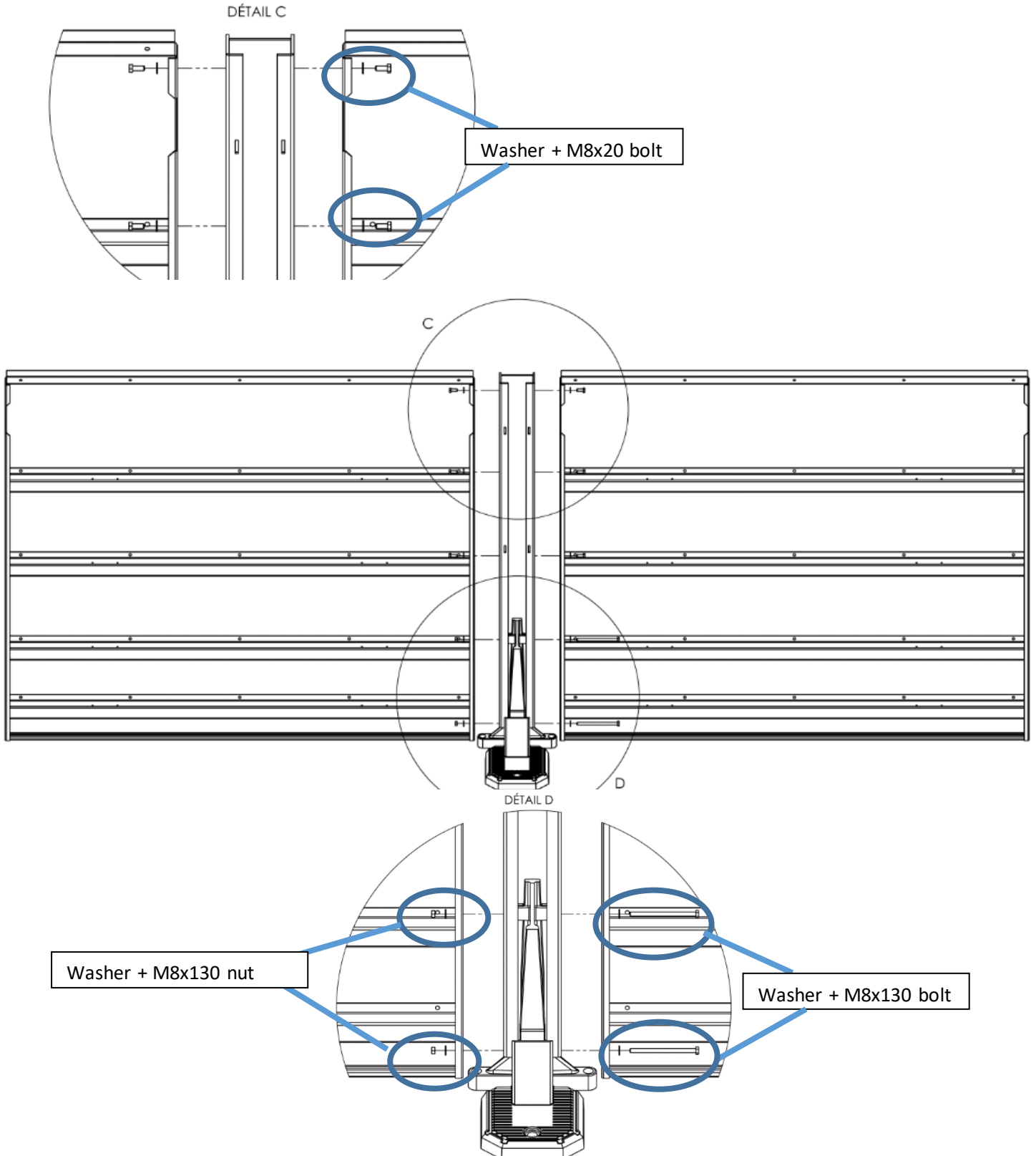

Assembling a 90° angle corner

Attach the upright/panel assembly using M8 x 20 bolts and washers

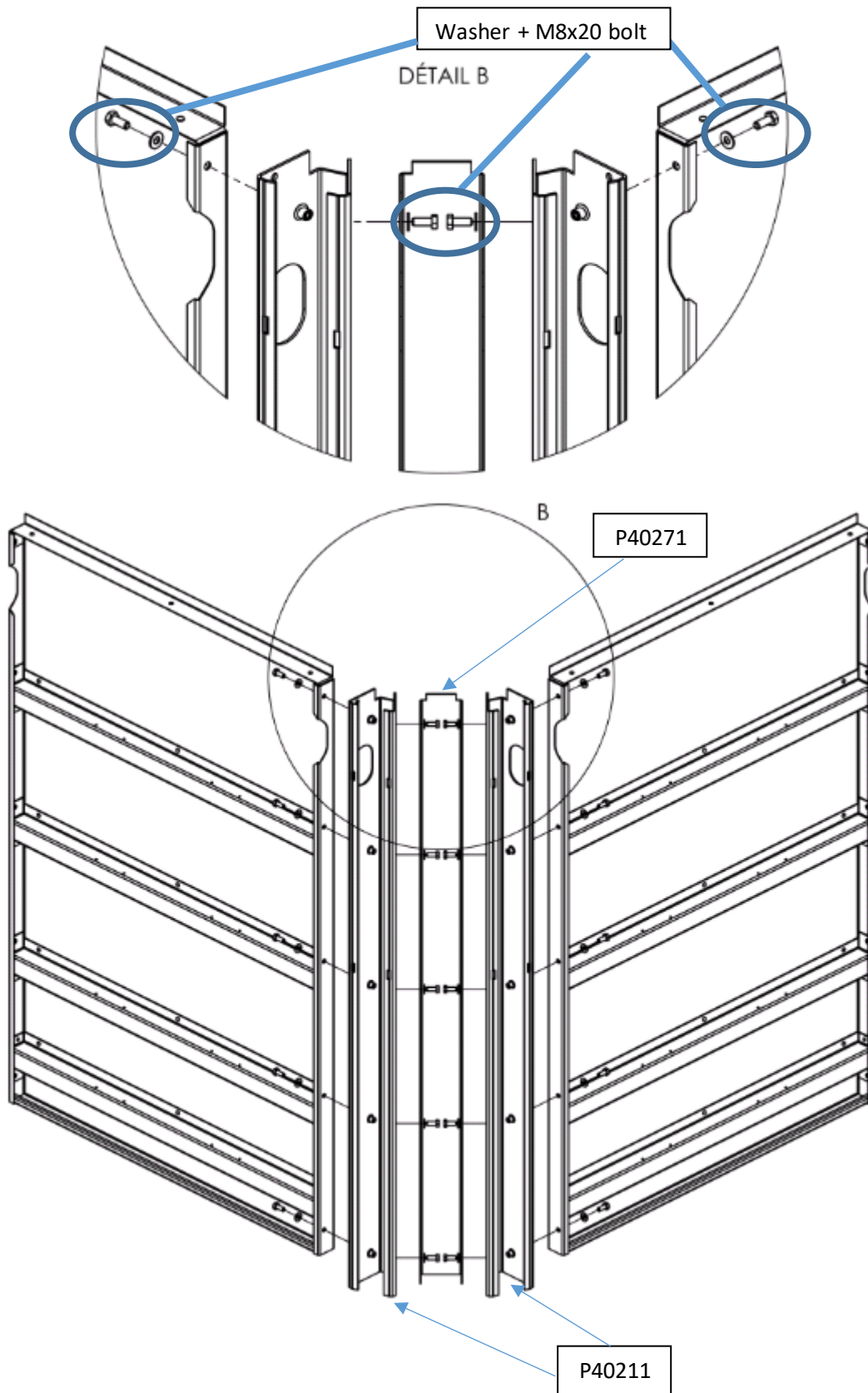

Once all of the panels and posts are assembled, check the inside pool dimensions against the drawing below.

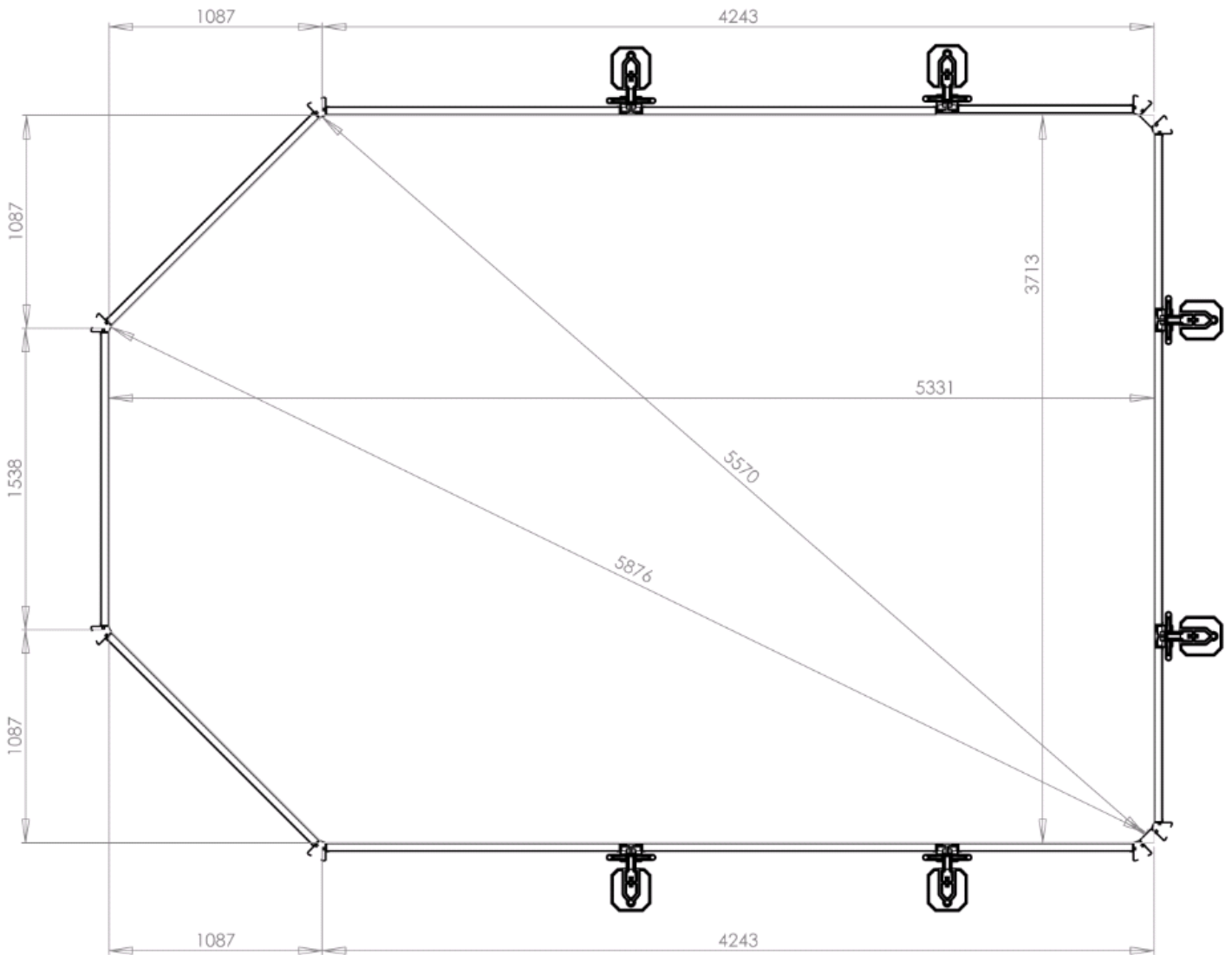

3. ASSEMBLING THE SKIMMER DRESS STRUCTURE

Assemble the composite upright skimmer dress supports using M6 bolts, washers and nuts.

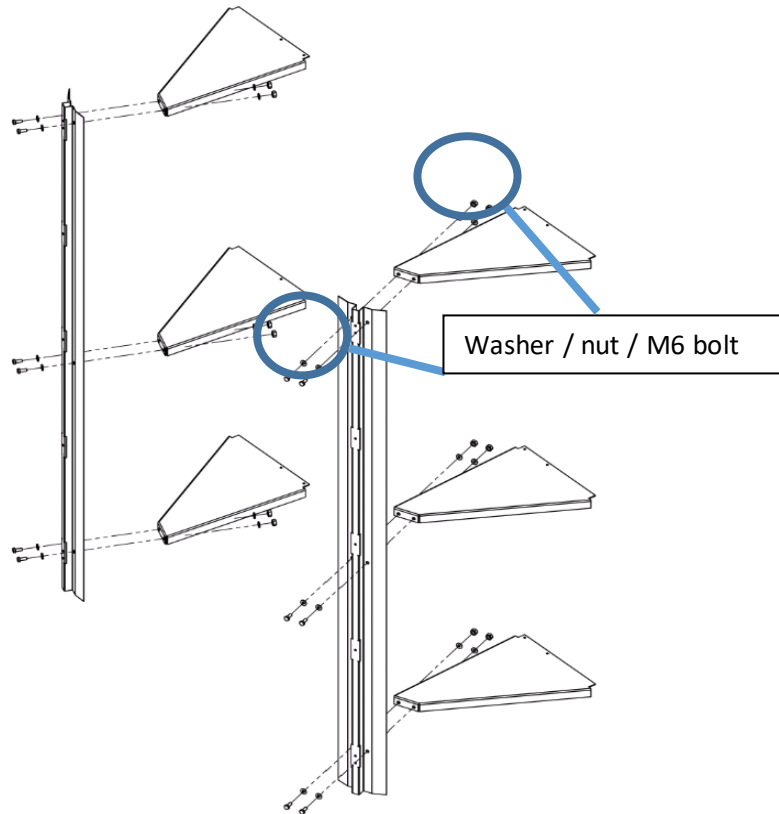

Assembly complete

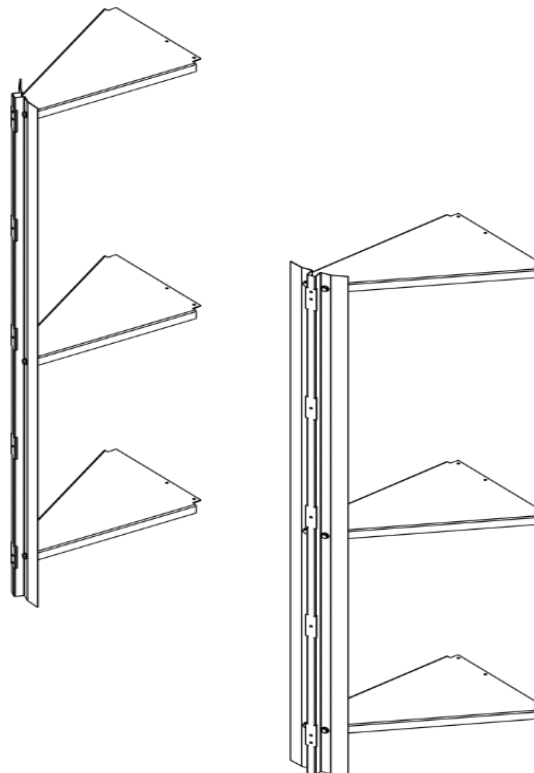

Assemble the composite wood uprights by sliding them into the metal uprights then attaching them with 3.9 x 9.5 mm sheet metal screws.

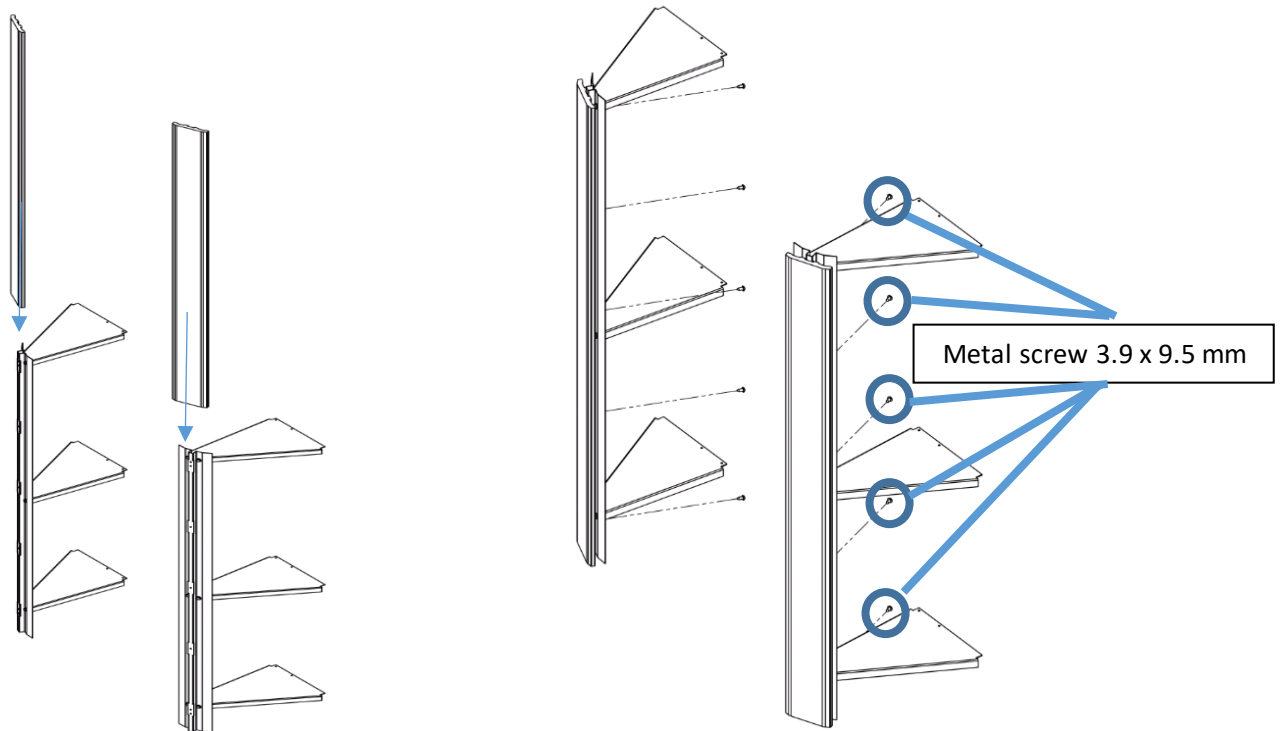

Now you can fit this assembly onto the skimmer panel using self-tapping screws into the pre-drilled holes.

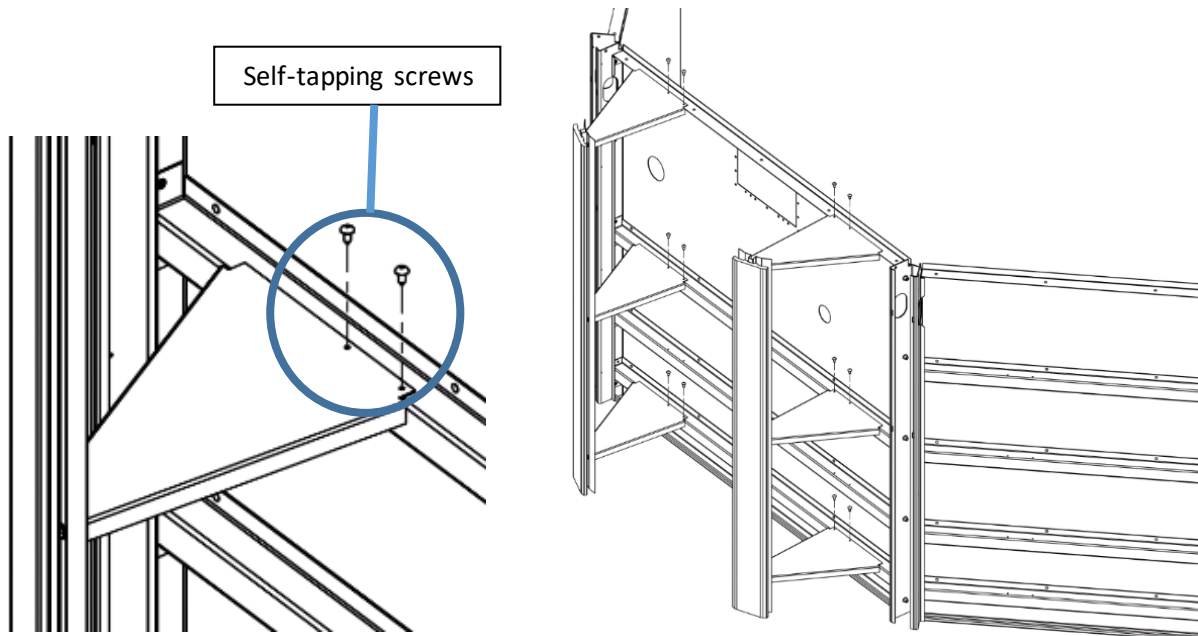

Install the composite upright supports onto the skimmer dress posts using 3.9 x 9.5mm screws.

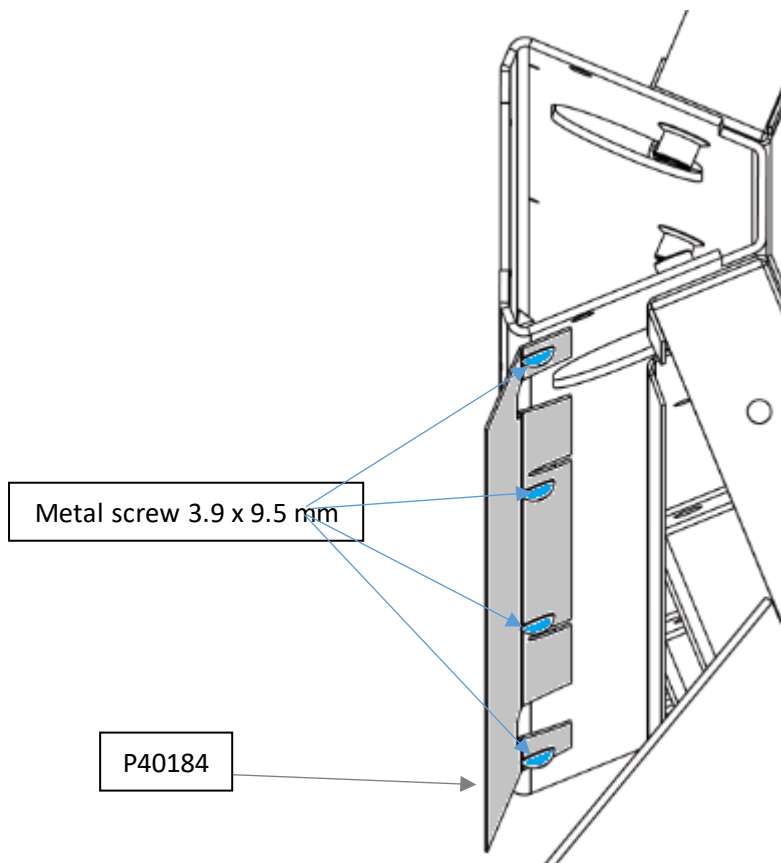
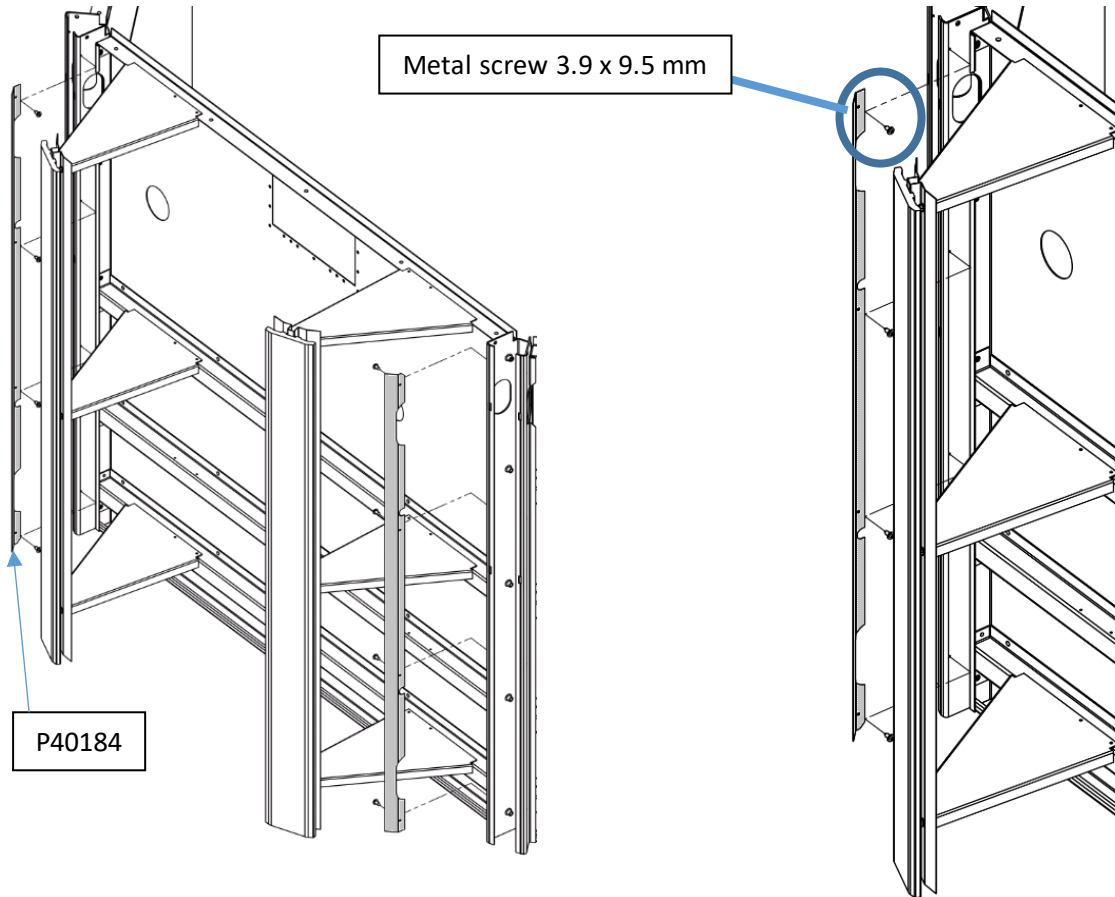

INSTALLING POOL FITTINGS

At this stage in the assembly work you need to install the first skimmer and return nozzle components. Take care to apply the zinc spray onto every panel cut-out prior to installation.

Fitting the first part of the RLPPP return nozzle

Glue the seal onto the nozzle body then pass the complete assembly through the panel. From the other side, tighten down the locknut.

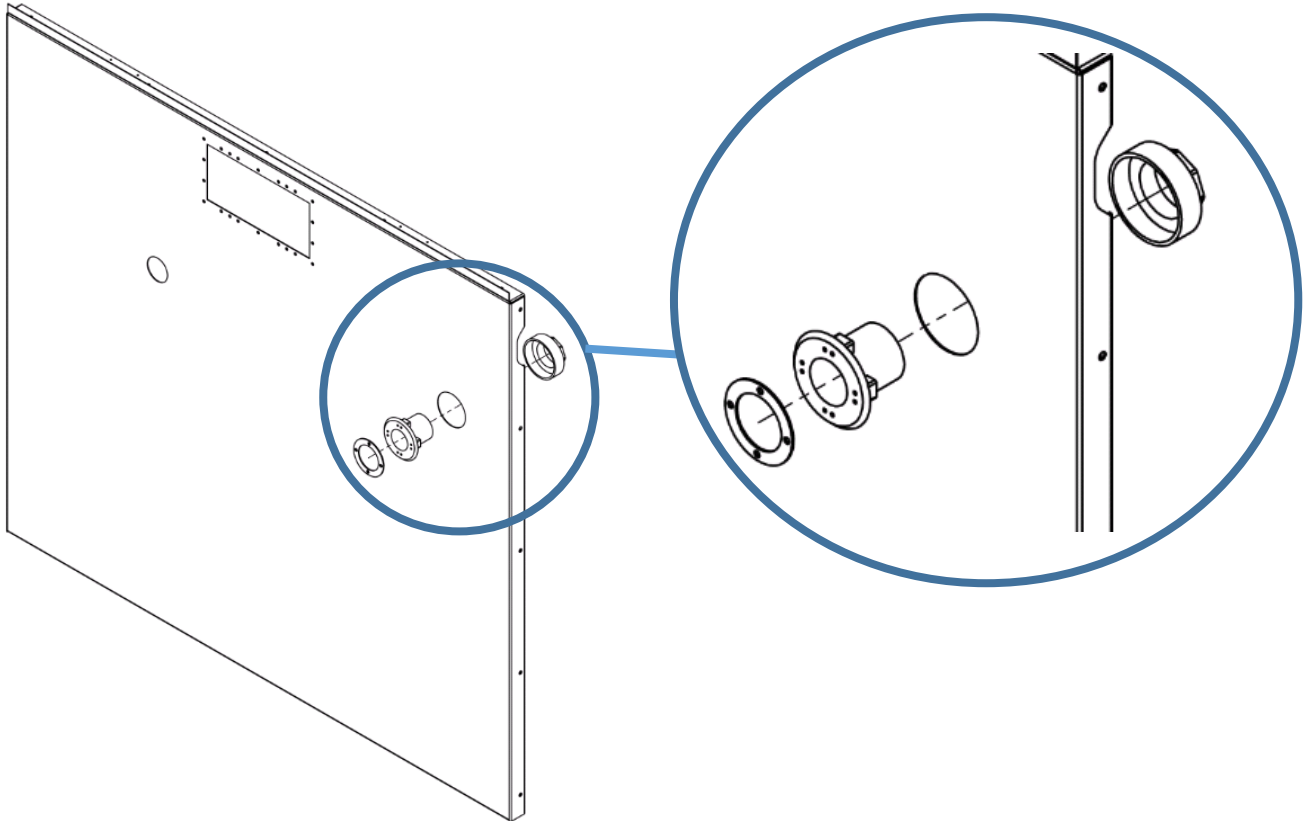

Note:

Second part of the nozzle

First part of the nozzle

Fitting the first part of the skimmer

First of all, take the double neoprene seal and pass it onto either side of the cut-out. Then take the skimmer body and the four screws and assemble it onto the skimmer panel.

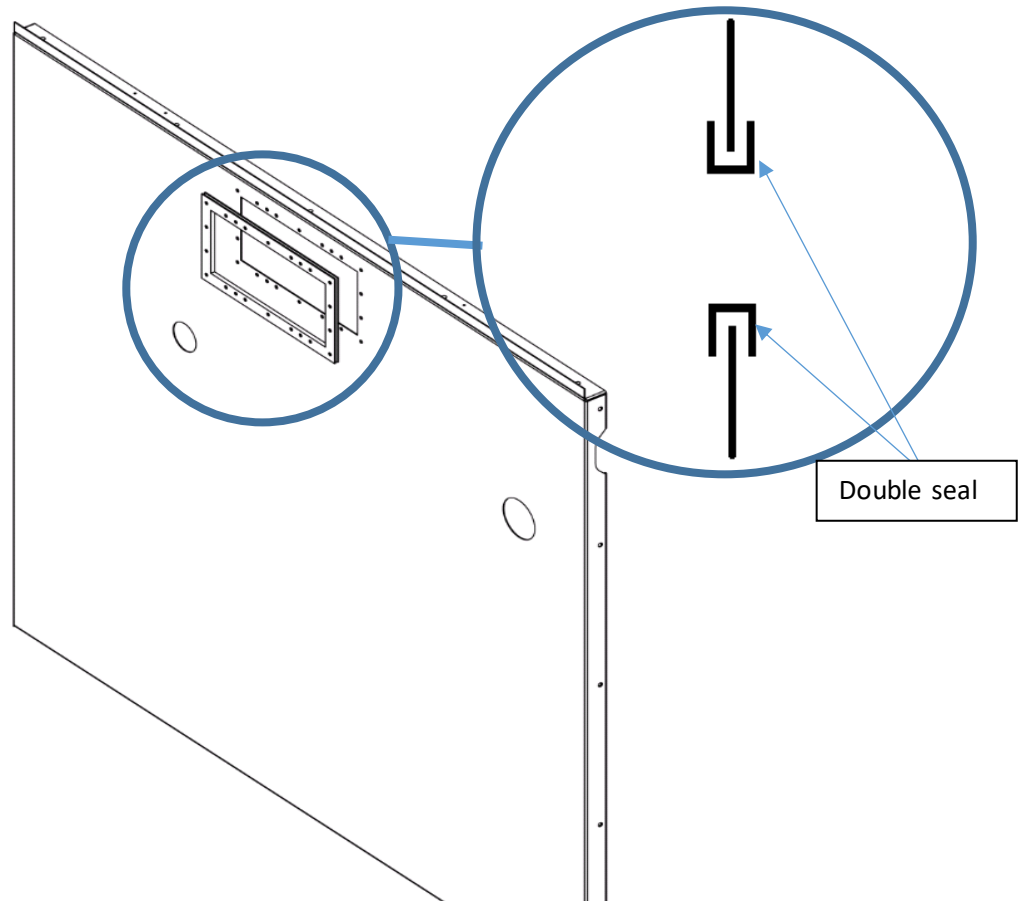

ATTACHING THE CAST IRON FEET TO THE GROUND

After first:

- assembling the structure
- checking the positioning
- checking the diagonals

a) Use a drill and an 18 mm drill bit to drill holes into the concrete slab through the holes in the cast iron feet

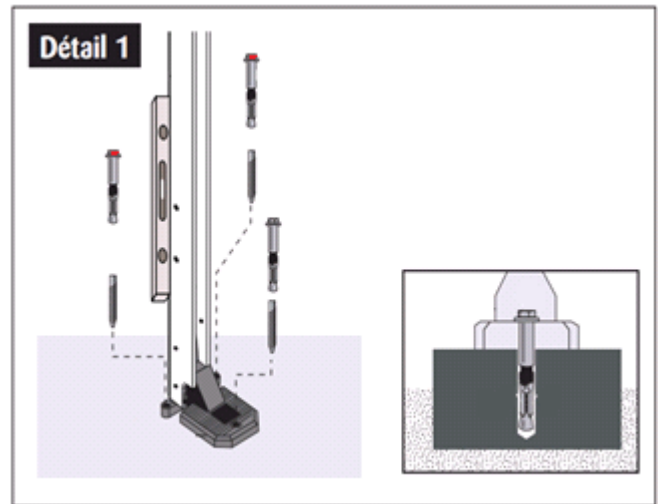

b) Place the mounting anchors into the holes without tightening them while taking care with the position of the torque mounting anchors.

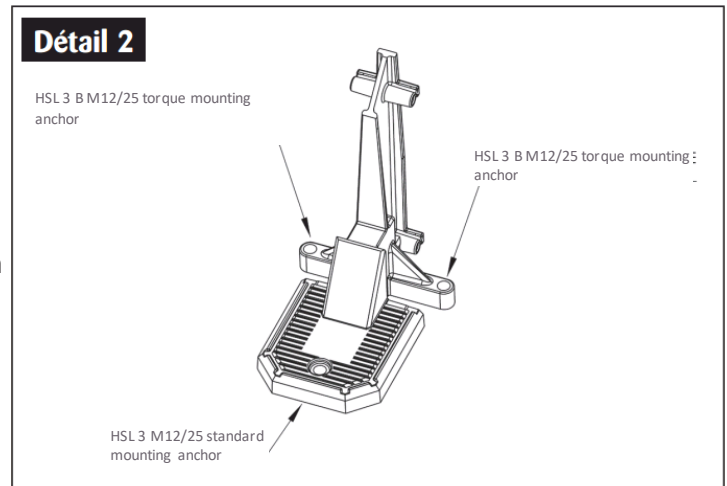

Remark:

A torque mounting anchor is differentiated from a standard mounting anchor by its red nut. When it is screwed down, the red nut breaks off when the tightening torque reaches the recommended 80 Nm tightness.

Essential:

Use a spirit level to check that the complete assembly is vertical and shim the cast iron foot if necessary.

Once the structure is level, add three shims under the mounting anchor, on the outside edge, to compensate for water pressure.

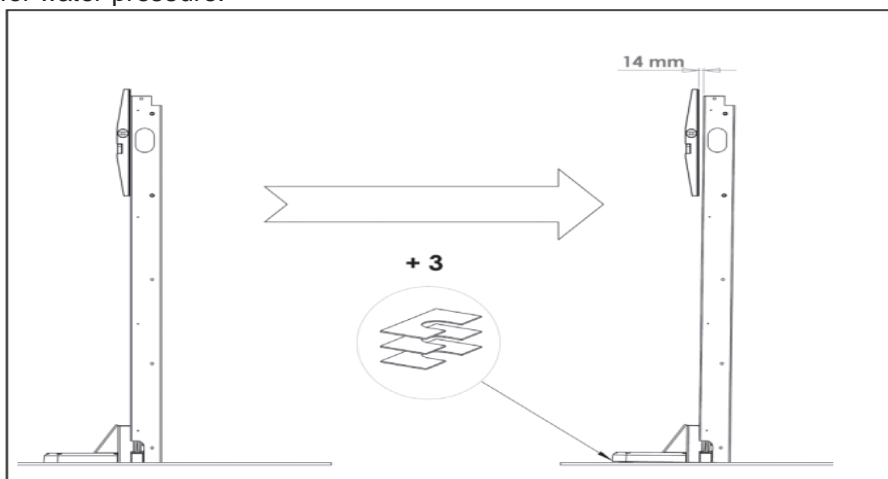

INSTALLING THE LINER

1. LAYING THE FELT

We recommend centring the felt panels in relation to the centre of the pool.

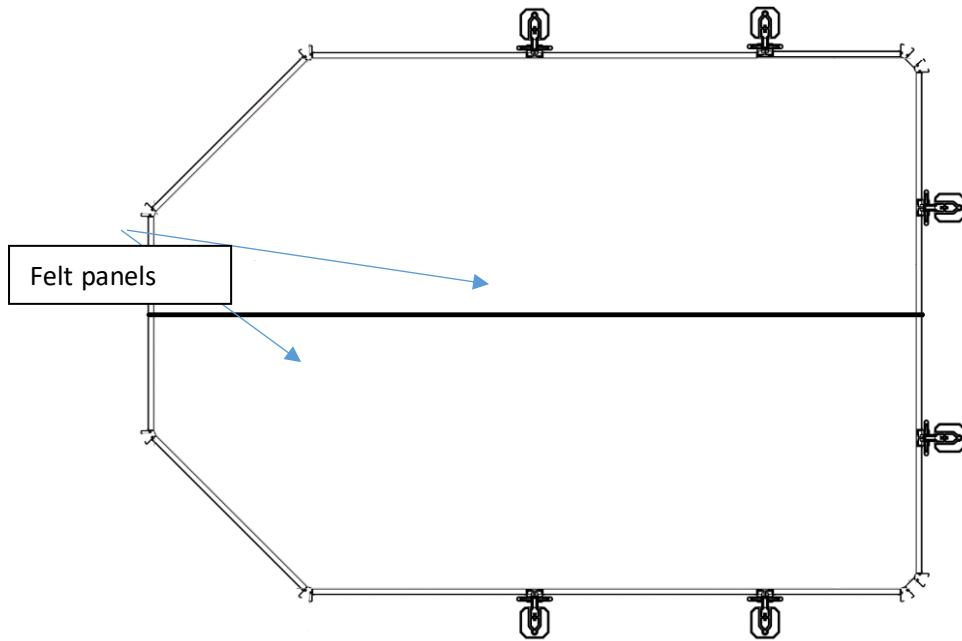

Attach the felt panels with tape (not supplied), first to each other, then onto the panels so that they will not move while installing the liner.

Cut the felt to the inside pool dimensions + 15cm so that there is an overlap against the side.

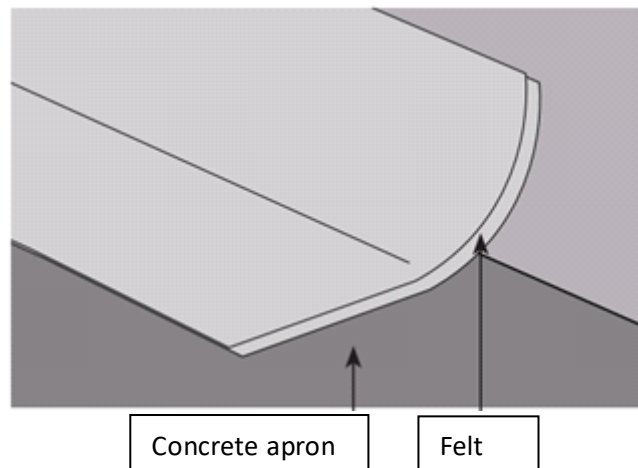

2. INSTALLING THE LINER LOCKS

Install the upper P20481 liner locks by slotting them into the top of the metal panels.

Warning: The liner lock mounts one way only. Place the liner installation slot towards the inside of the pool.

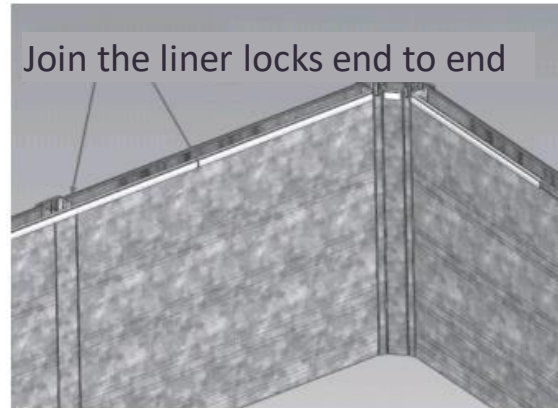
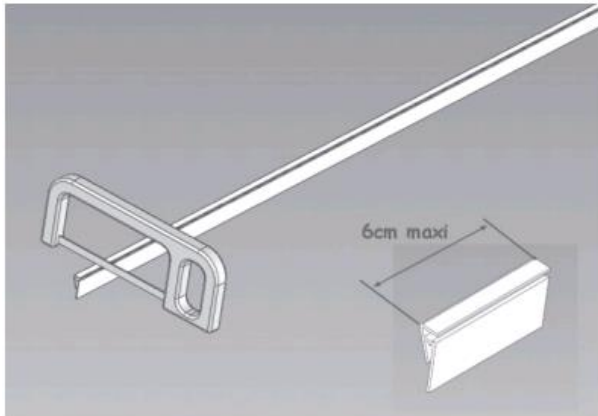
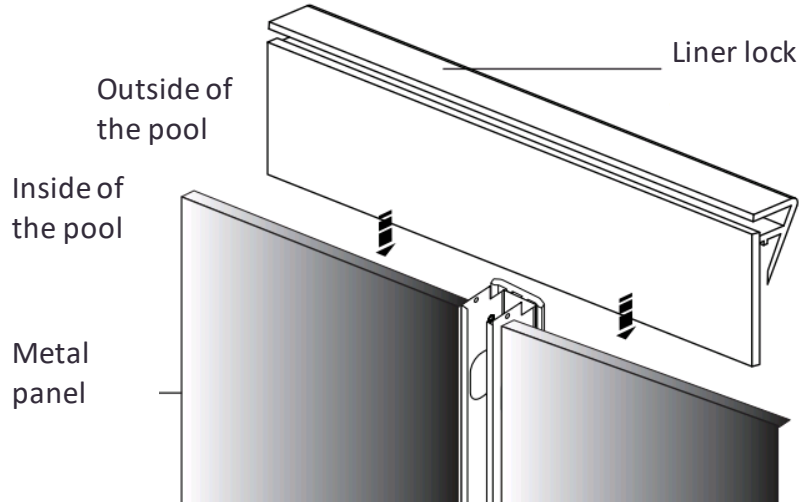

Place liner lock between two posts

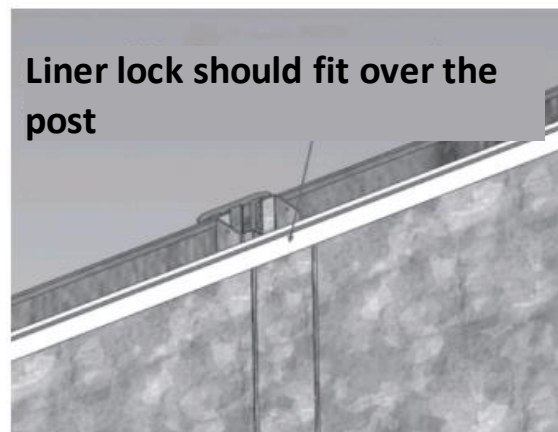
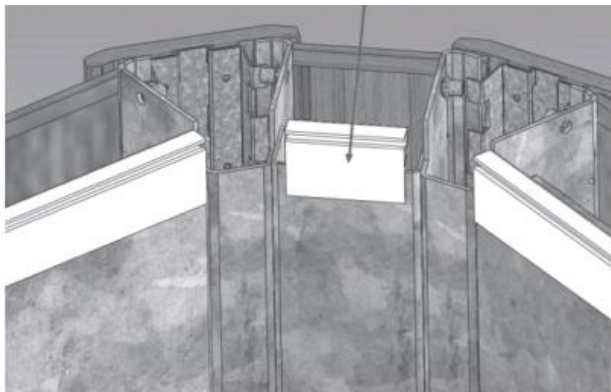

The liner is made of PVC. PVC can stretch very considerably. This is why for some models the height and dimensions of this liner are slightly less than the height

and dimensions of the pool. Once filled, the liner stretches and fits up against the structure at the bottom of the pool thanks to the weight of the water.

A liner is installed on a good weather day when the temperature is between 15°C and 30°C. Failure to comply with this requirement may cause deterioration to the liner and exclude it from warranty cover.

A minimum of two people are required to do this. Do not smoke during this step.

Please comply with the installation procedure point by point.

1. Clean the structure and the bottom of the pool of any dirt that may damage the liner.
2. When entering the pool, do so barefoot or in stocking feet.
3. Take the box containing the liner and place it in the centre of the pool.
4. Open the box WITHOUT USING A BOX CUTTER OR ANY OTHER CUTTING OBJECT!

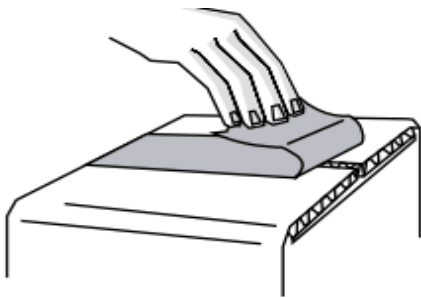

5. Remove the liner from the box.
6. Unfold the liner without pulling on it, but by lifting it

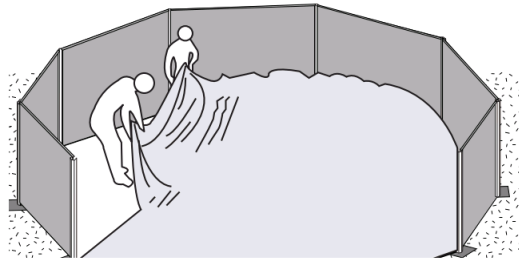

7. Position the outer weld (the one across the base and the vertical part) at equal distance from the metal structure (as the bottom of the liner has a smaller surface area than that of the pool). The weld along the vertical part of the line must be parallel to a vertical edge of a metal panel.

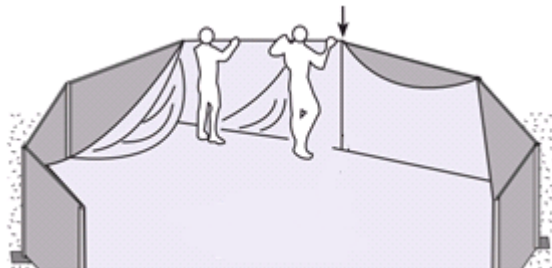

8. Attach the liner to the liner lock, then insert the hung stop taking care to follow the phases shown below.

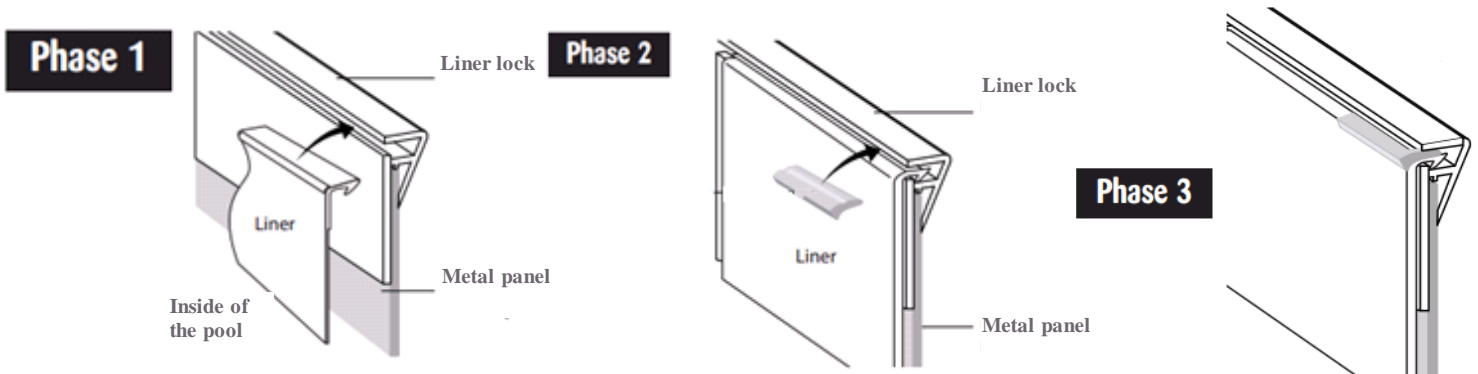

Check that the tension is uniform around the edge and that there are no diagonal folds across the bottom of the pool. At this stage, these folds must absolutely be avoided. If necessary, reposition the liner. Stretch the bottom of the line with your heel and by pulling from the centre outwards.

By lightly pressing your foot against the sidewall/bottom edge, make sure that the folds in the vertical sides will disappear once the liner tensioned by filling. Remove any oblique folds by moving the upper part of the liner.

FILLING THE POOL

Reminder: Before starting, first read all of the points in this section.

1. Start by running water (from the mains water supply) into the pool and eliminate by hand the few folds that may remain on the bottom, by pushing them towards the outside of the pool.
2. Be sure to identify the difference between packaging folds (false folds) that will disappear under the weight of the water and positioning folds (double layers of material that can be pinched between two fingers) and that need to be eliminated or they will remain in place definitively.
3. Remember that once there is at least 3cm of water in the pool, you will no longer be able to move the liner.
4. During filling, make sure that the liner lock remains in place. Click it back into place if necessary.

⚠ When the water level is 5-10cm from the nozzle opening, stop filling the pool

Installing the spotlight sidewall mounting and installing the spotlight

This is the level where you will proceed to install the spotlight. To do this, follow the steps set out below:

1. Make a cross shaped cut-out in the liner at the spotlight opening level
2. Slide a seal over the spotlight sidewall mounting

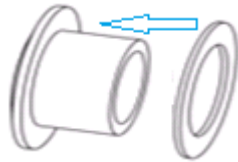

3. Place the other seal between the liner and the pool sidewall and push the sidewall mounting through this hole. As a result, your liner is clamped between the two seals.
4. On the skimmer dress side, lock the sidewall mounting using the tightening nut

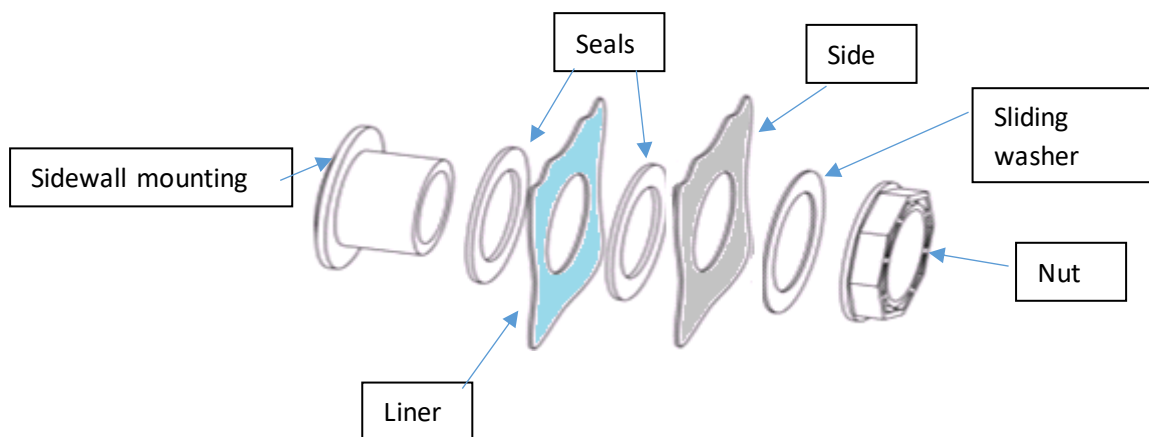

Using a detergent, clean the PVC components. To glue the parts, place the blue glue on each element and assemble them. Note that the glue sets very quickly. Be sure to have all of the parts you need to hand and, if necessary, do a dry run assembly first to avoid mistakes.

Proper bonding can be seen when a collar shaped overflow of glue appears once each of the parts has been glued together.

5. Glue the pipe into the female part of the elbow, then Teflon coat the male thread on the elbow.



6. Screw the complete assembly into the spotlight sidewall mounting on the skimmer dress side
7. Take a length of string and run it through the top of the tube until it comes out of the elbow



8. Once in the pool, take the spotlight and attach its electric cable to the string coming out of the elbow, then pull the string until it comes out of the top of the PVC pipe, then screw the spotlight into the spotlight sidewall mounting

NOTE: When connecting your spotlight to a connection box, we recommend filling the box with insulating silicone gel (not supplied).

Before continuing to fill the pool, first assemble the skimmer's water circuits.

BEFORE DOING ANY GLUING, DO A DRY RUN ASSEMBLY FIRST

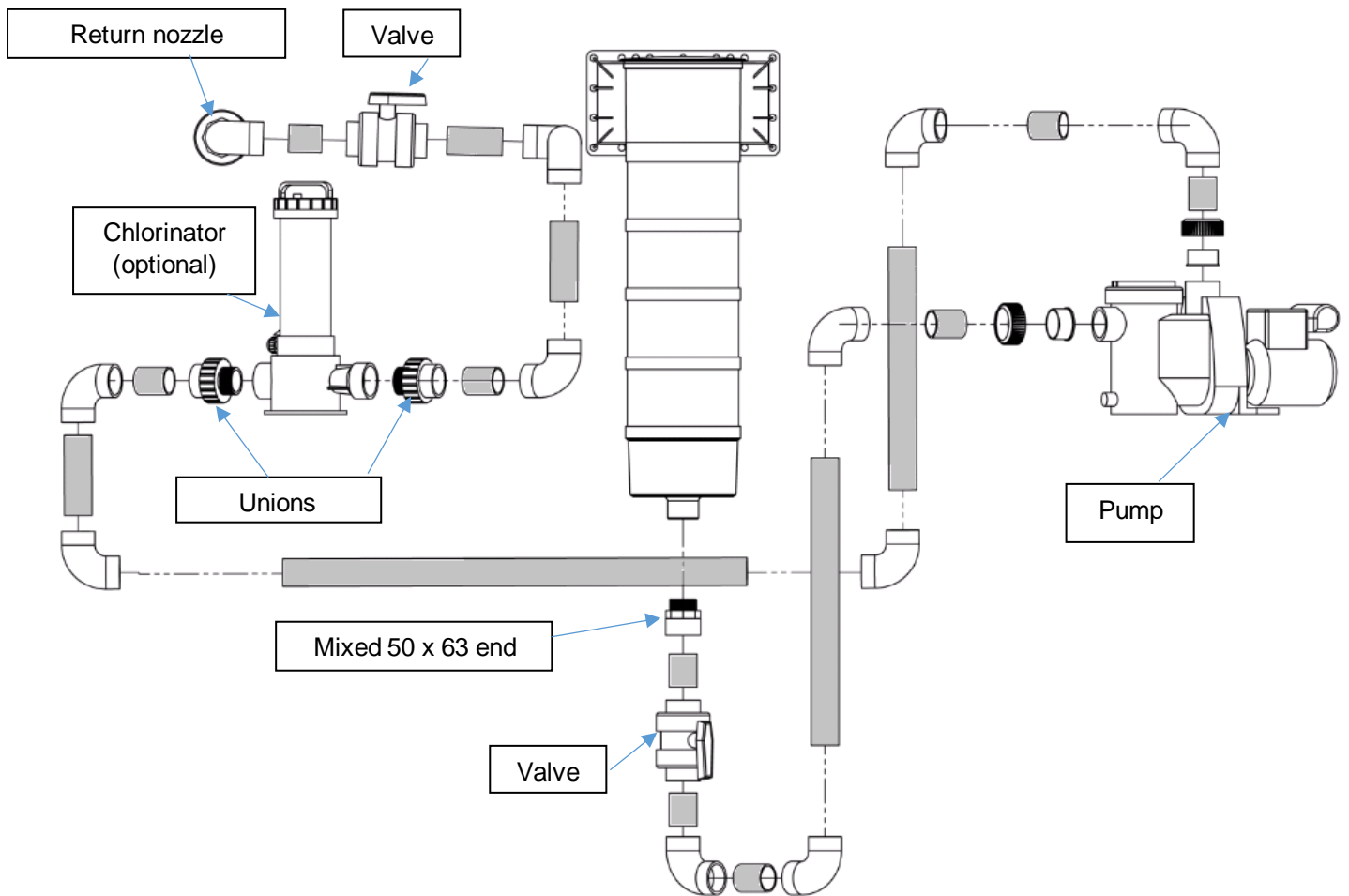

To ensure proper gluing: Using a detergent, clean the PVC components. To glue the parts, place the blue glue on each element and assemble them. Note that the glue sets very quickly. Be sure to have all of the parts you need to hand.

IMPORTANT: A 24 hour period is required for the glue to dry properly and ensure water circuit sealing.

Finished assembly diagram

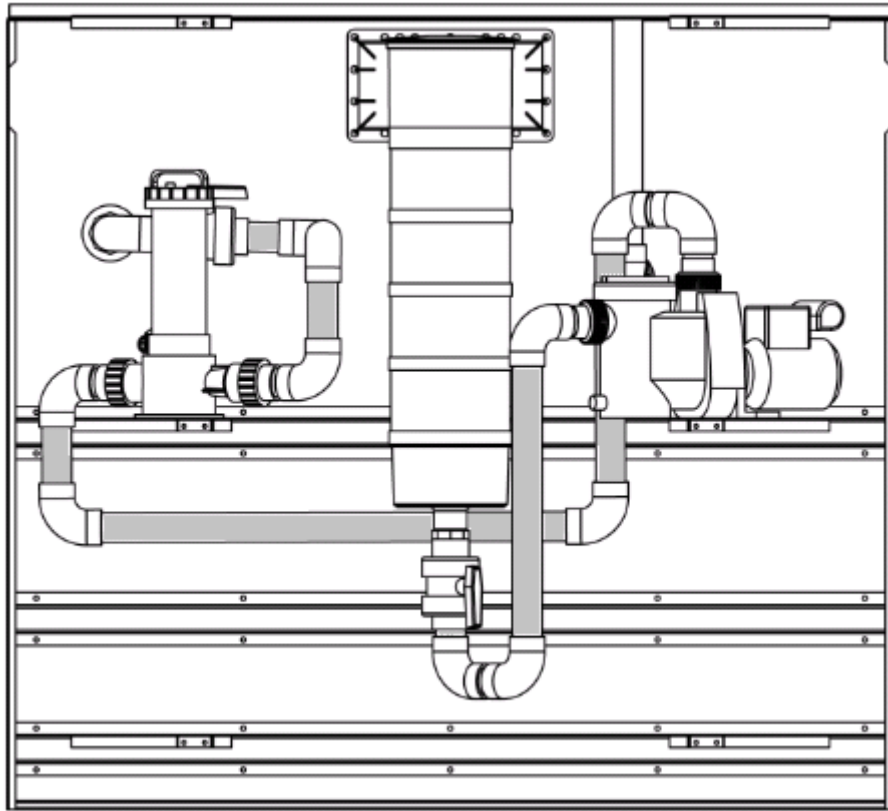

Fitting the **second part** of the return nozzle

1. Identify the threads and mark them with a pen



2. Pierce a hole using a small screwdriver, press the flange flush and screw down



3. Make the cut-out using the flange as your guide

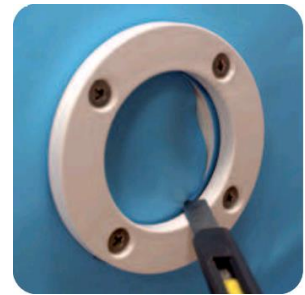

4. You can finish assembling the nozzle by screwing down the return ball nozzle, inserting it into place and tightening down the complete assembly with the flange

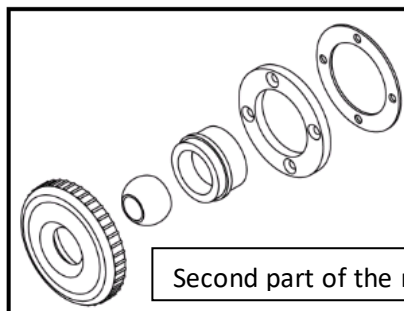

Second part of the nozzle

Continue filling the pool

⚠ When the water level is 5-10 cm from the skimmer opening, stop filling the pool

Fitting the flange and the skimmer flange cover

1. Just like for the return nozzle, find the skimmer mouth threads with your finger (we recommend that you find all four corners) and mark them with a pen or a felt tip.
2. Take the skimmer flange and press it against the pool sidewall, aligned with your markings. Pierce a hole using a small screwdriver through one of the markings, take a screw and screw in but do not tighten it completely.
3. Repeat the operation for each screw.
4. Tighten the complete unit down all the way and clip the flange cover on.
5. Proceed to cut-out the line from the skimmer mouth using the flange cover as your guide. Follow the diagram shown below to avoid damaging the double seal during the cut-out operation.



INSTALLING COMPOSITE ELEMENTS

Assembling the uprights on their metal support

Slide the P40806 upright supports into the upright, then screw them down using the 3.9 x 9.5 mm sheet metal screws.

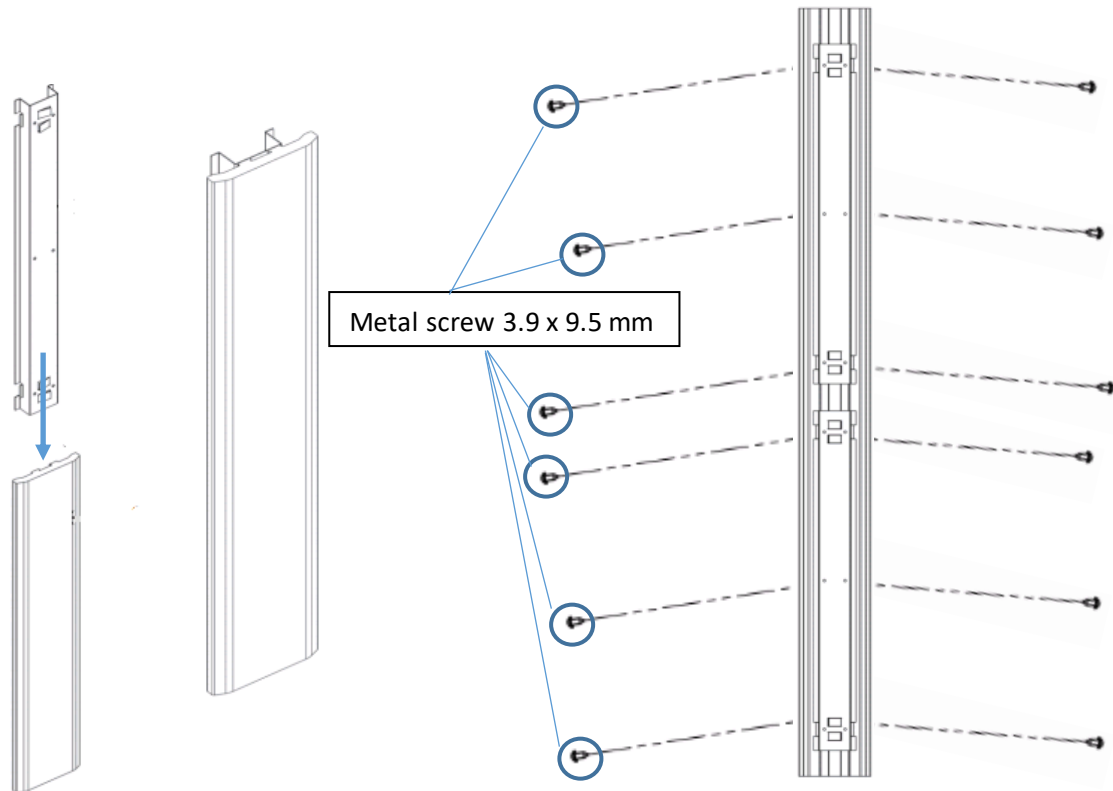

To finish, slide the assembly into the post.

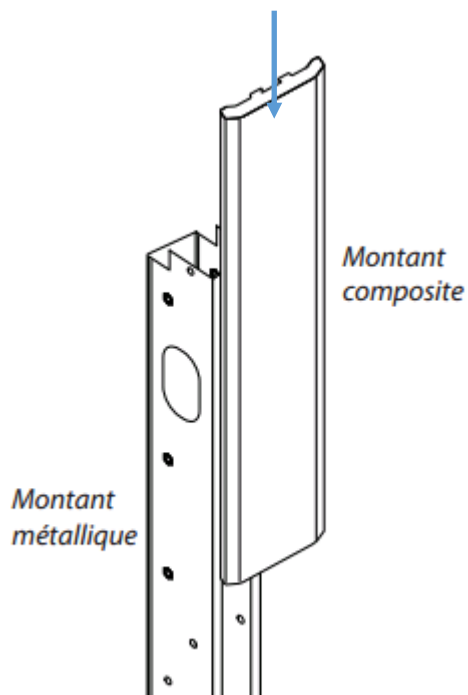

Installing the composite facing parts

Every facing part offers you a choice between a smooth side and a side with two small grooves. This choice means that you can customise the visual appearance of your pool facing. When you ordered your pool, you chose the colour of your facing parts, so you can also customise the visual appearance of your pool by slotting in the facing parts as you wish.

Pool outer surface choice

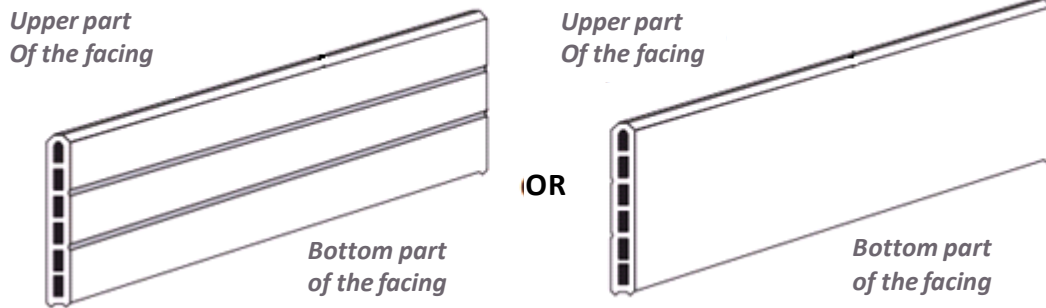

Above-ground pool

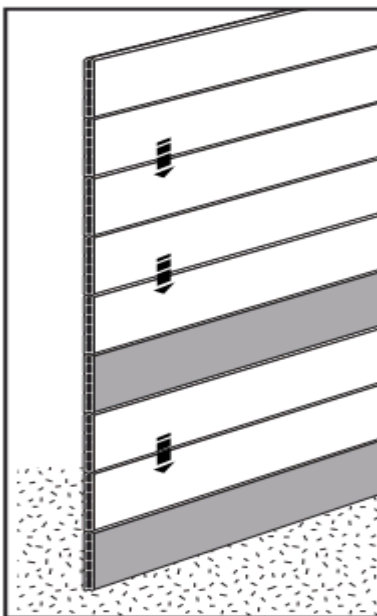

Nine facings for a 1.40 metre high pool

- Seven identical colours
- Two different colours



Installing the plates/flanges/nuts

Take a 10 mm wrench and the M6 bolts and washers to attach the plates and install them on all of the appropriate posts.

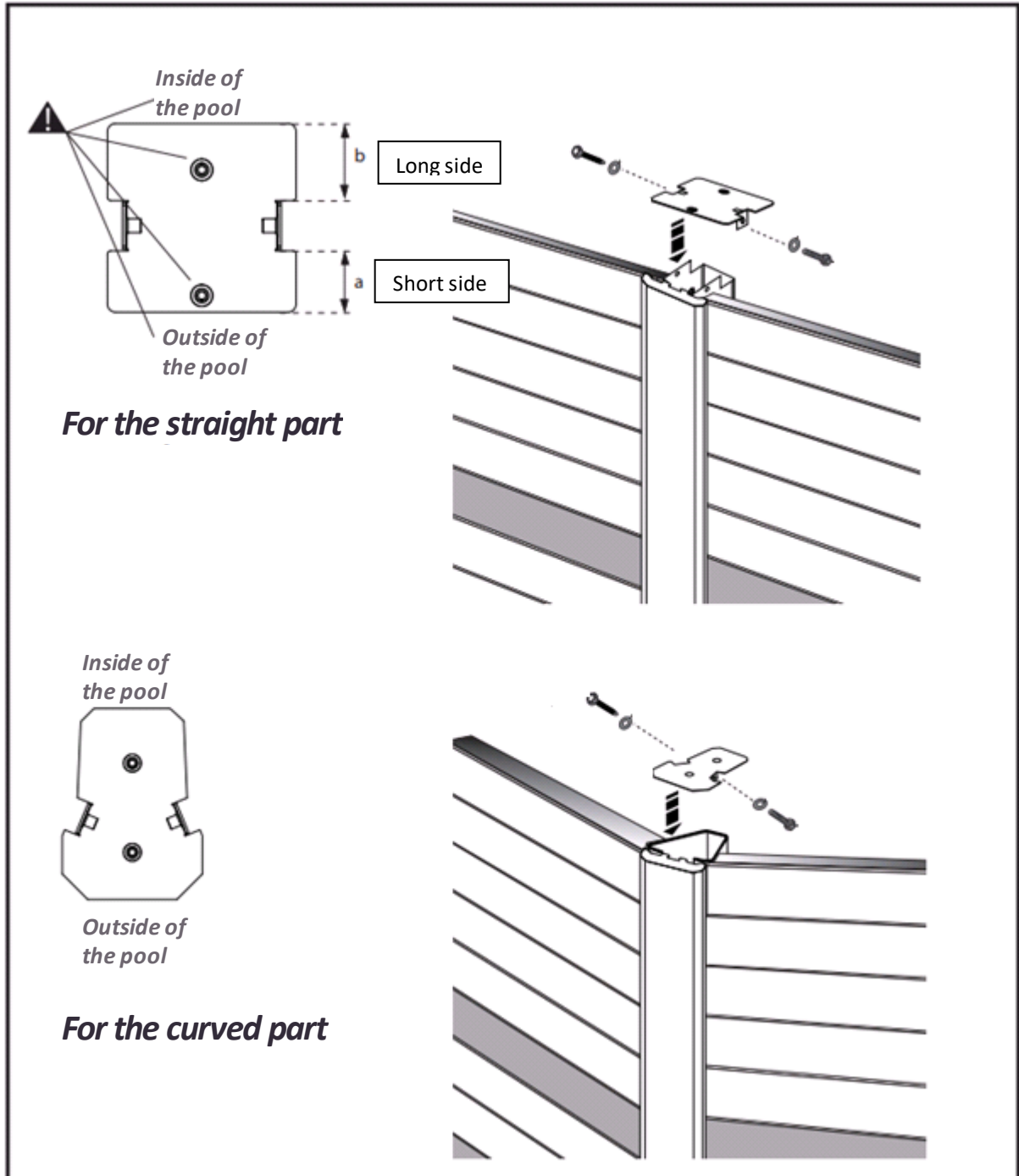

Installing the first flange

Install the first mounting flange and the nut onto the plate using the bolts and the nuts provided. The nut needs to slide freely. Now alternate the fitting of a coping and a flange all around the pool.

 **Do not tighten down fully. The assembly should remain mobile so that you can adjust the copings' positioning later on.**

Corner flange

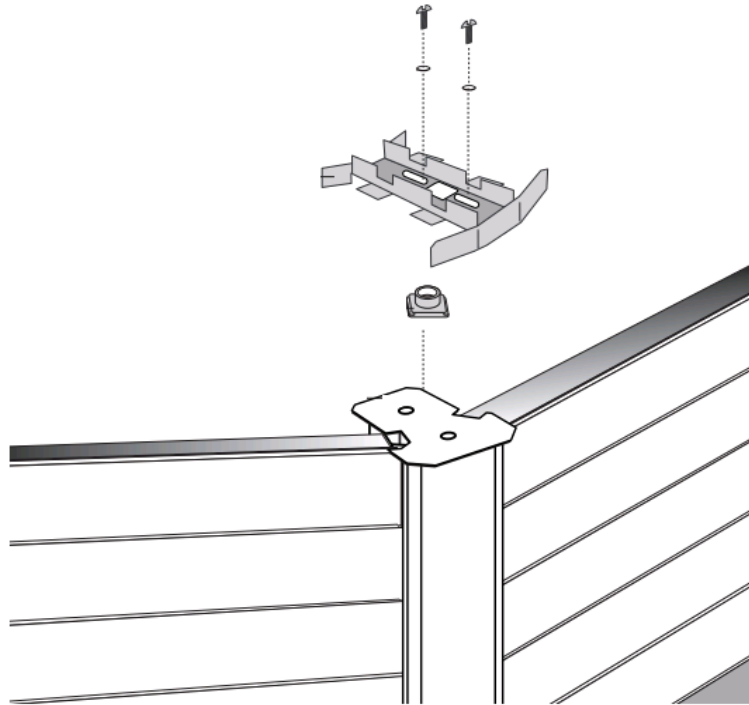

Straight flange

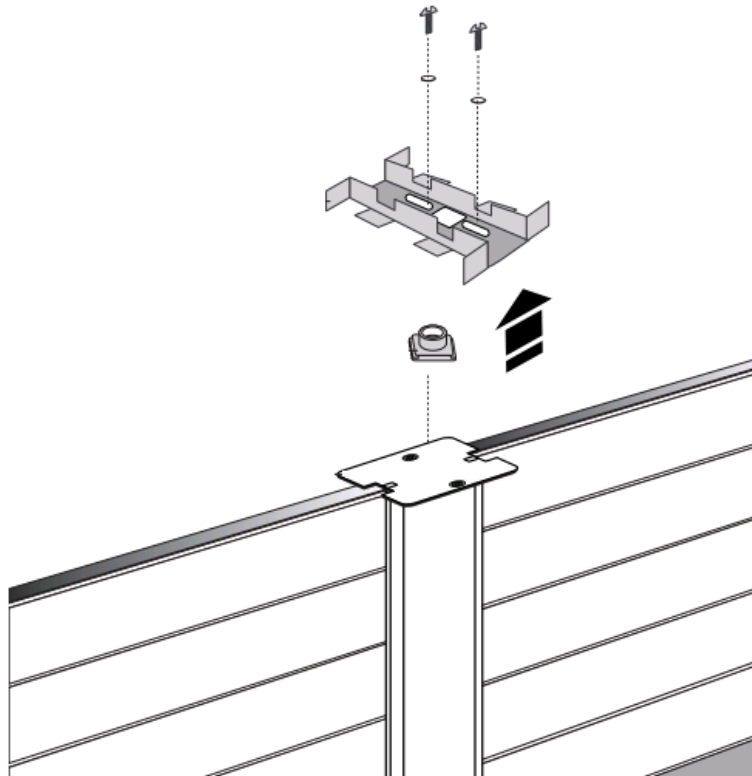

Installing the copings

You can work from the skimmer panel, for example. Slot one end of the coping into the mounting flange taking care to ensure that:

- The tabs (a and a') do slot into the holes (b and b') in the upper deck,
- The tabs (d and d') do slot into the holes (c and c') in the upper deck.

At the other end of the coping, slot in the flange tabs as shown and attach the complete assembly to the plate using the bolts and the washers (do not tighten down fully).

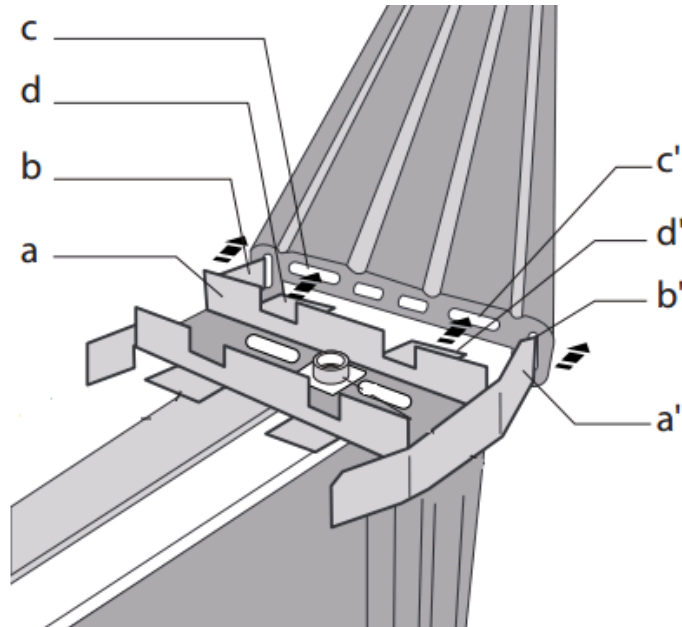

For the last coping

To slot the last coping into the plate, proceed with the following phases:

Phase 1: slot the tabs (a, a' and b, b') of the mounting flange into the coping holes (d, d' and c, c').

Phase 2: Refit the complete assembly and attach it using the bolt washer.

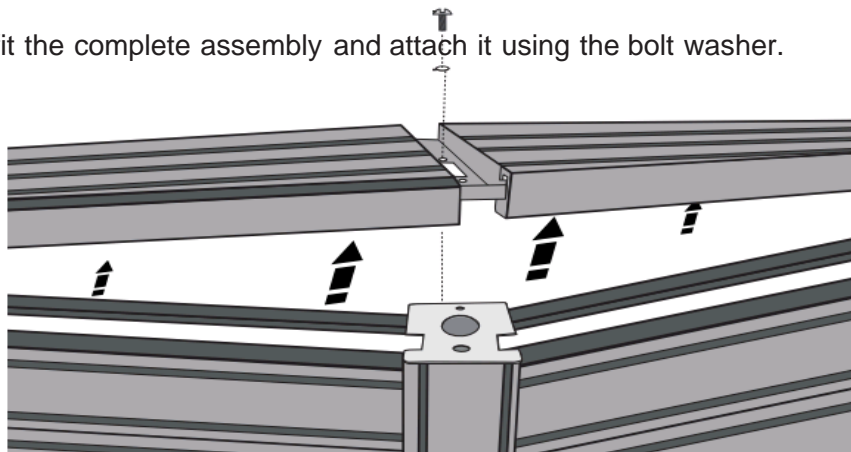

Reposition and centre the copings by lightly “tapping” their outer sides.

 **Very important:** Make sure that the edges of the copings offer a 3 - 5 mm gap with the flange edges. This gap is important as it allows the copings to expand.

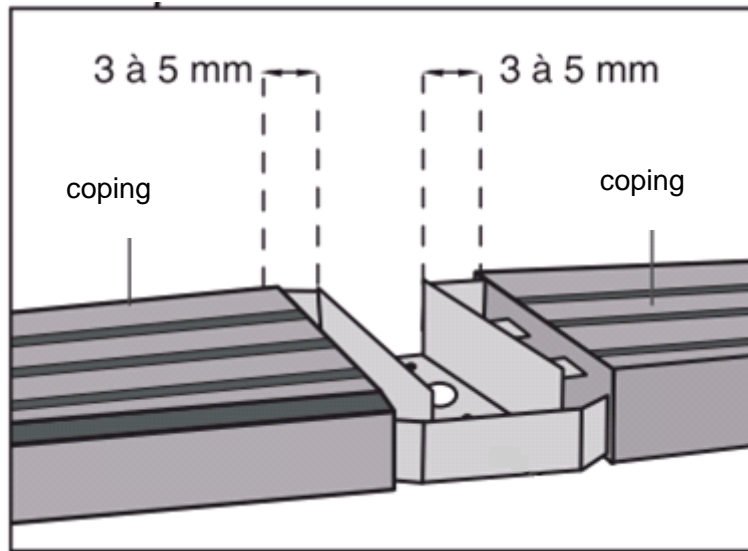

Definitively tighten down all of the flange bolts

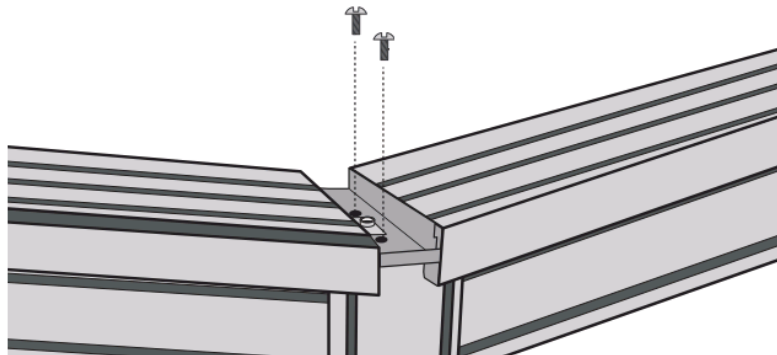

Fitting the rings

Fit the multi-function rings onto the mounting flanges using the M6 bolts and washers.

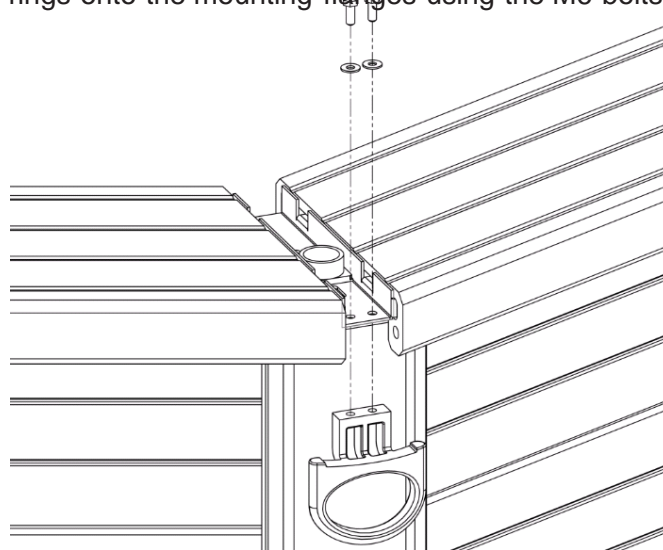

Fitting the copings' covers

At this stage, you can install all of the copings' covers except the ones on the skimmer panel.

Slot the join covers into the mounting flange on the upright and slide them along using the grooves.

Note: The inside pool join cover is longer than the outer pool join cover.

Place the washer over the join covers. Note that this part mounts in one direction and comes with a groove.

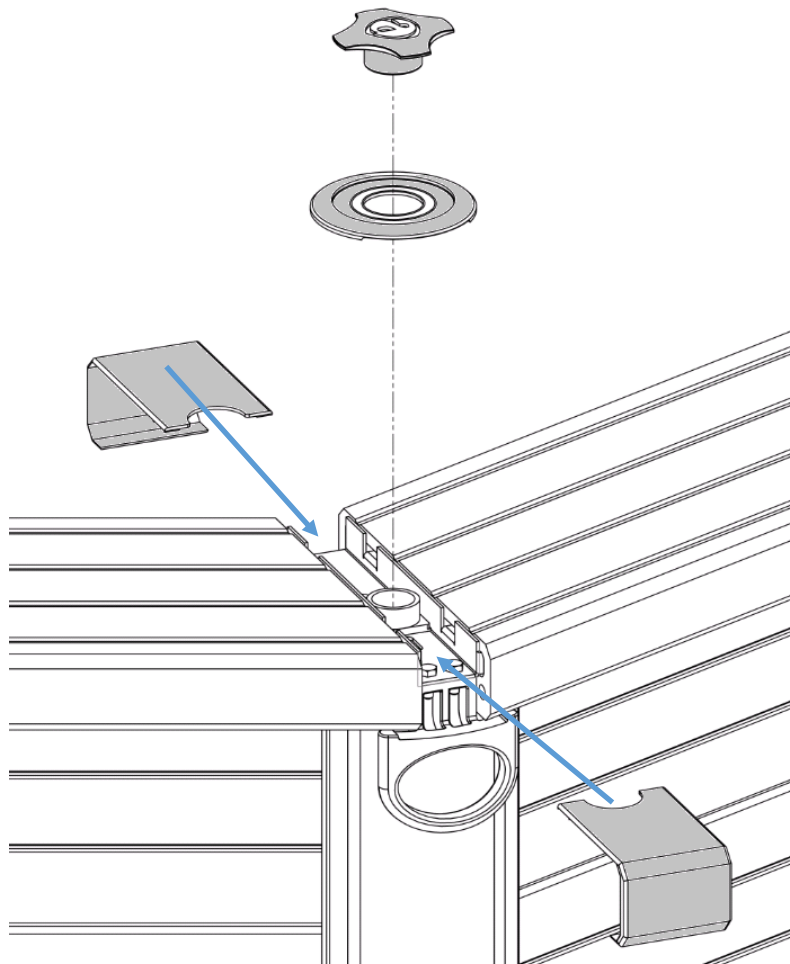

SKIMMER DRESS ASSEMBLY FINISHING PARTS

Note: Before fitting the cover, add your skimmer dress facing parts.

Installing the access cover

Place the coping support against the longest end of the coping and use screws to attach it.

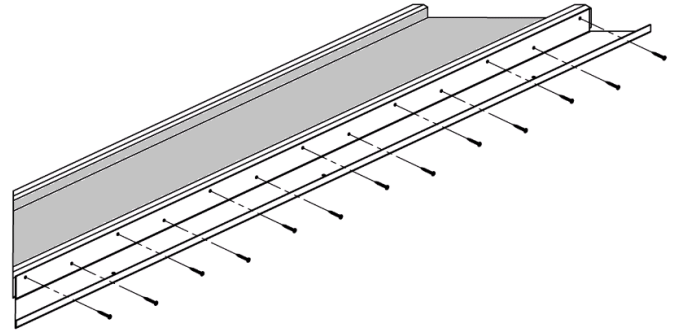

Attach the hinges to the coping support using bolts, washers and nuts.

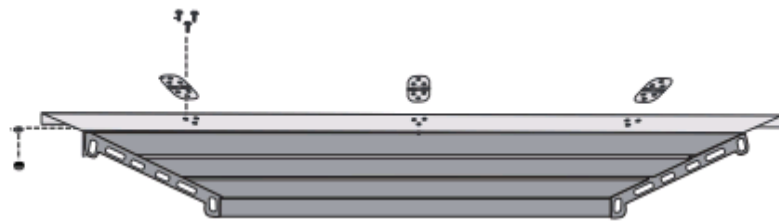

Slot the coping edge covers onto the coping.
Use screws to attach them.

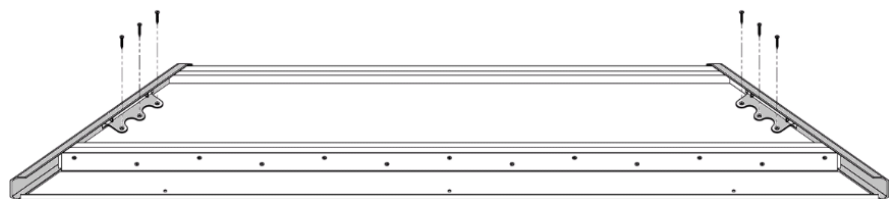

Note: It is sometimes necessary to tap the stainless steel part using a rubber mallet to properly slot it onto the coping.

Place the complete coping + support assembly into position on the skimmer dress.
Position the hinges.
Mount them onto the pool coping using screws.

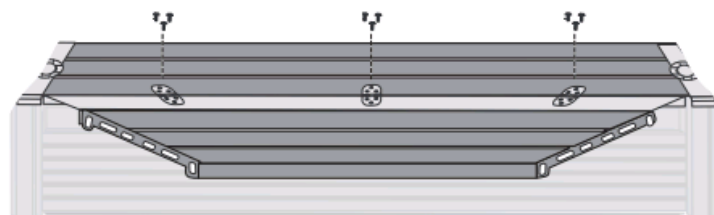

INSTALLING ELECTRICAL CONNECTION BOXES

Electrical safety box (P20619)

This box serves to cut the general power supply to your swimming pool when you open the skimmer dress.

Ready drill the skimmer dress side facing part then screw down the electrical safety box using the screws provided for this purpose. The switch will be located as shown in the picture above.



Electrical programming box (P41056)

This box is used to program the filtration operating periods and to switch the spotlight on or off.

This box will be installed at least 3.5 metres away from the pool.

Please refer to the instructions for the box provided inside of it.



Parts list

Number	Description	Quantity
P40189	Ladder structure left HS	1
1	WPC side left HS	1
P39080	Safety box for above-ground ladder HS	1
P40190	Ladder structure right HS	1
2	WPC side right HS	1
4	Ladder safety hoop length 1365	4
3	Ladder steps	4
P39571	AZTECK 3 ladder mounting	1
P39079	Metal ladder box	1

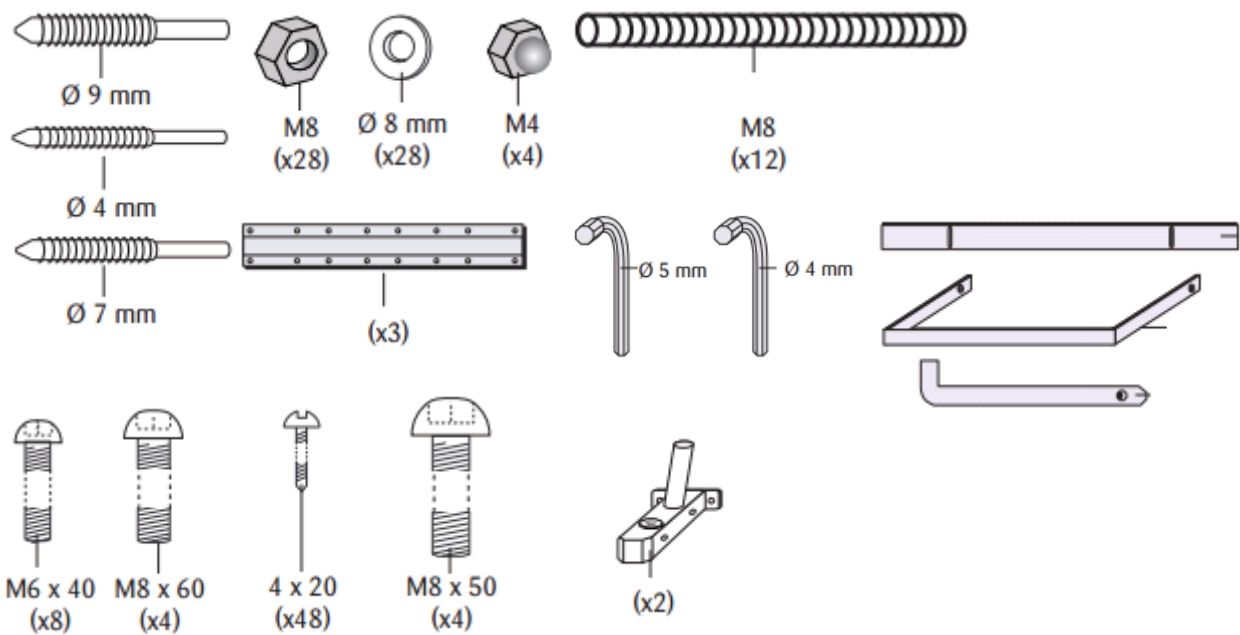
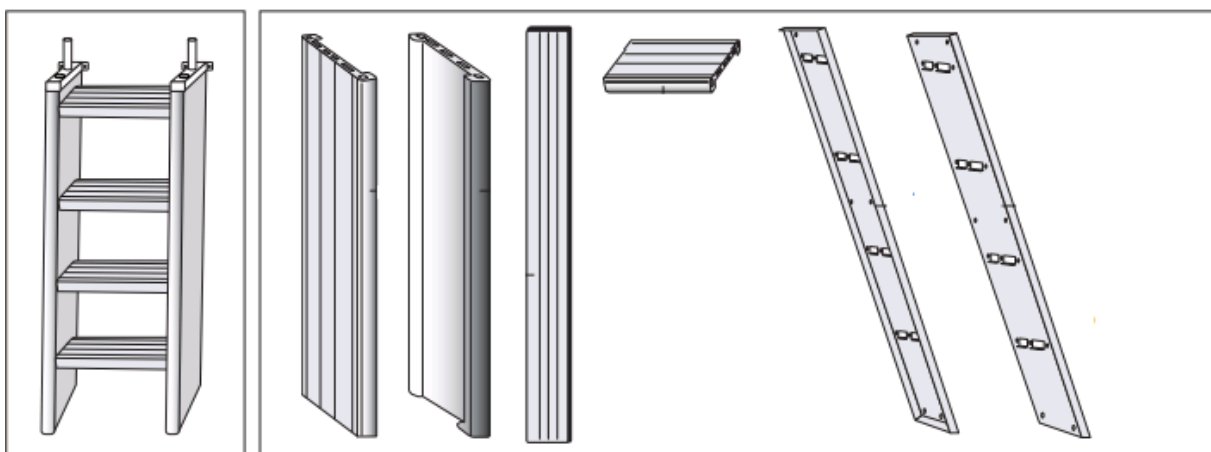

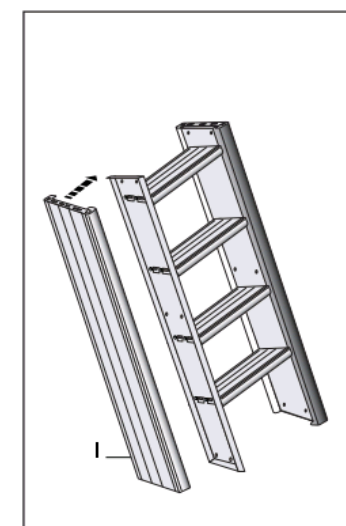
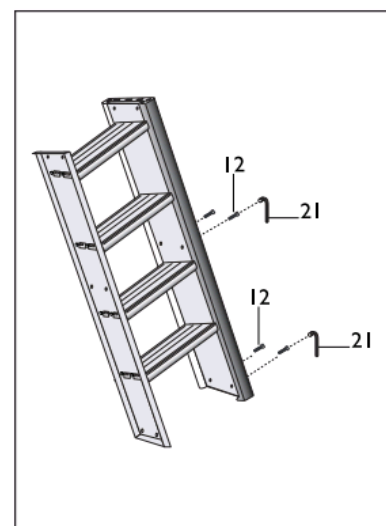
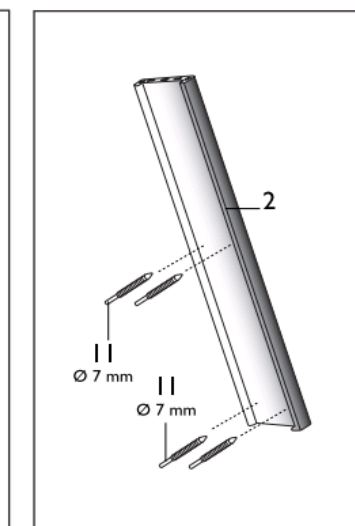
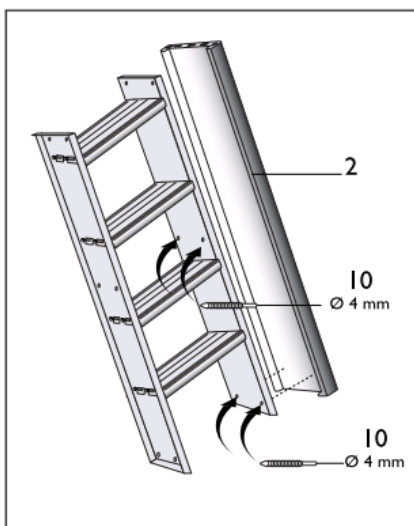
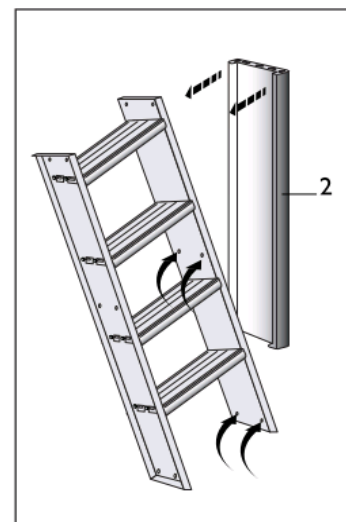
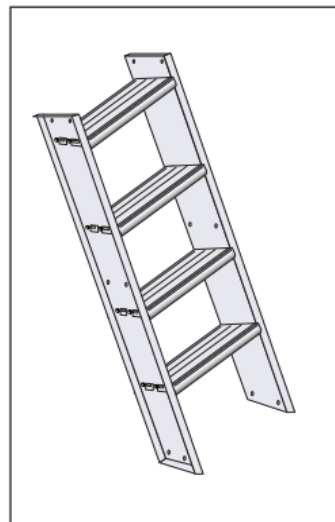
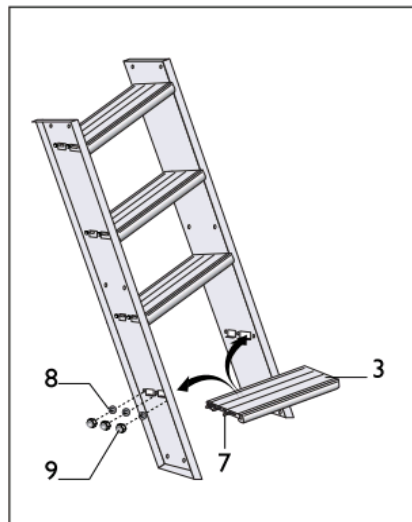
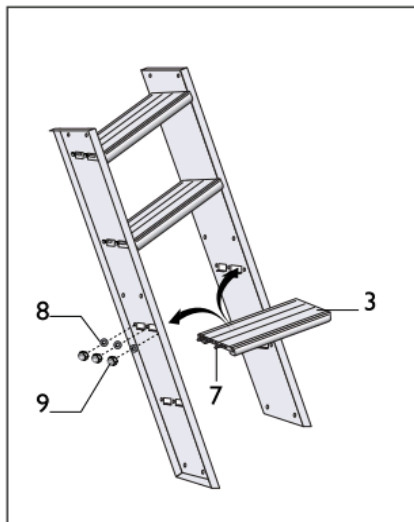
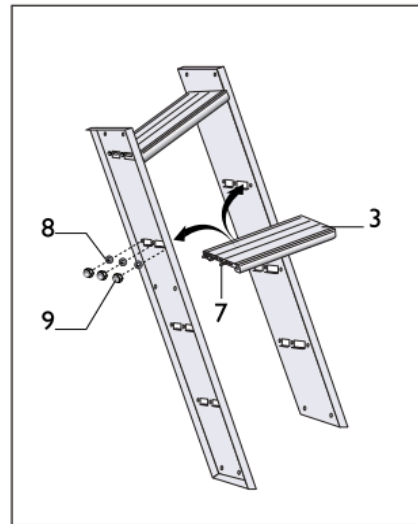
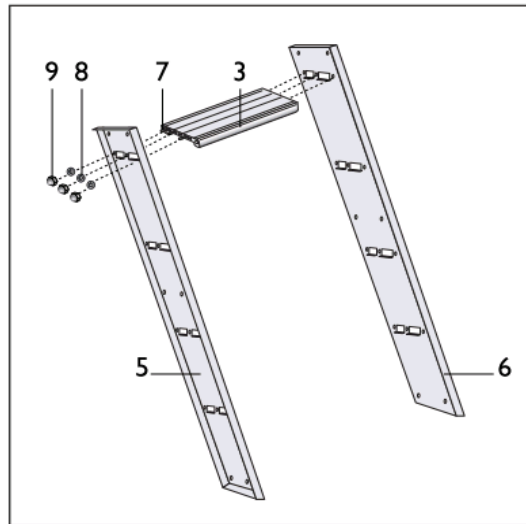
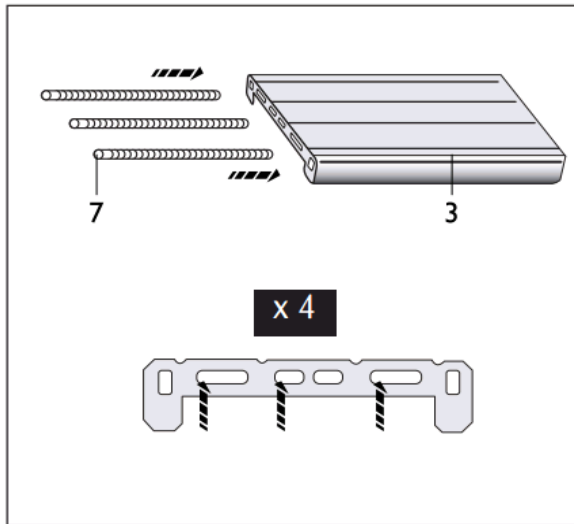

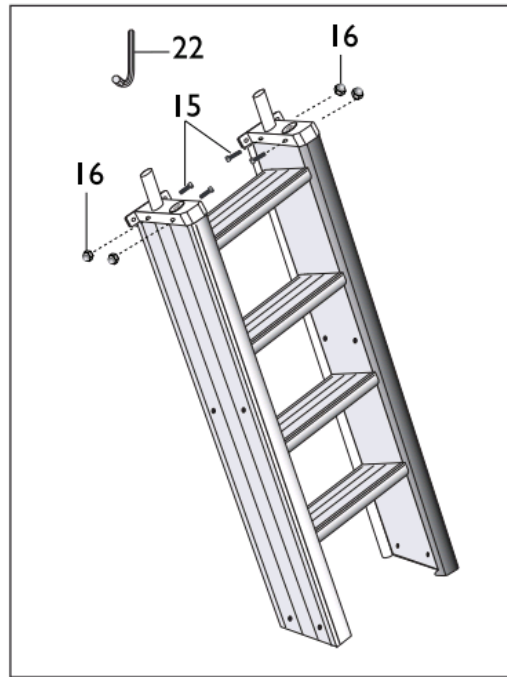
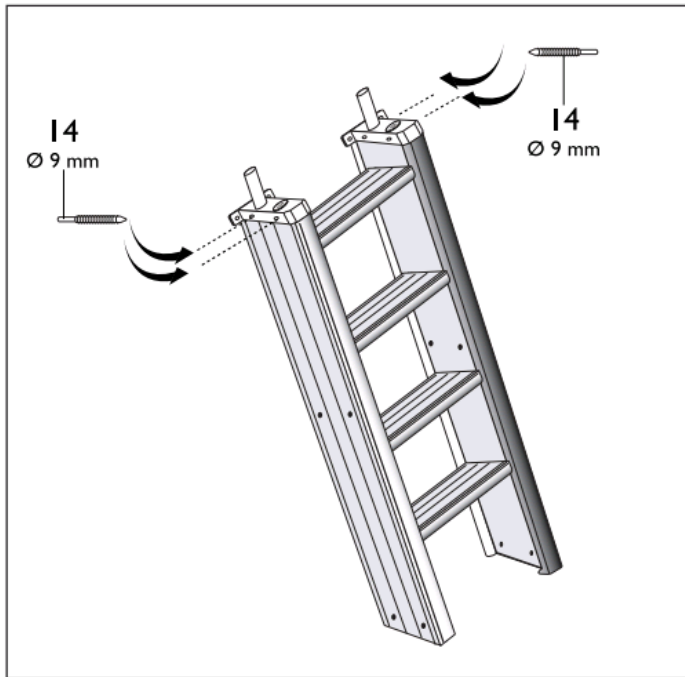
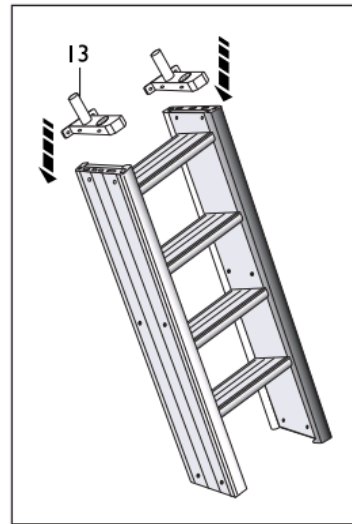
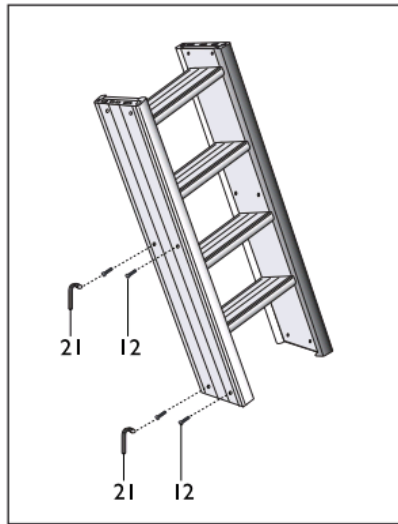
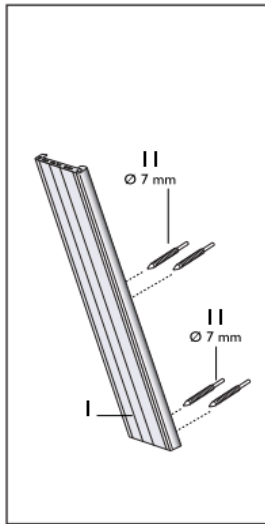
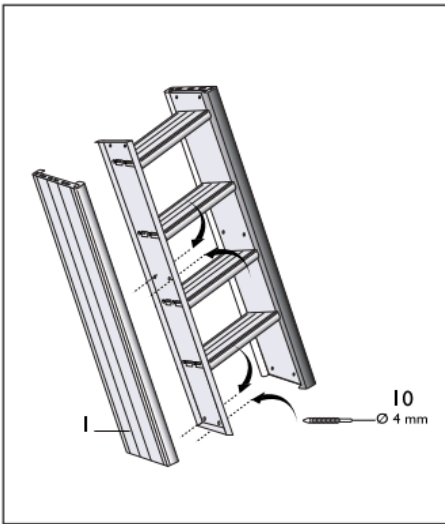

Mounting the ladder onto the metal structure

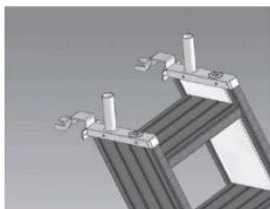
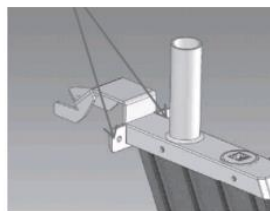
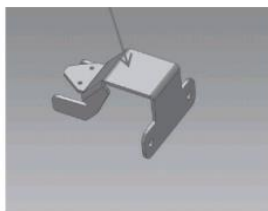

Mounting the safety part

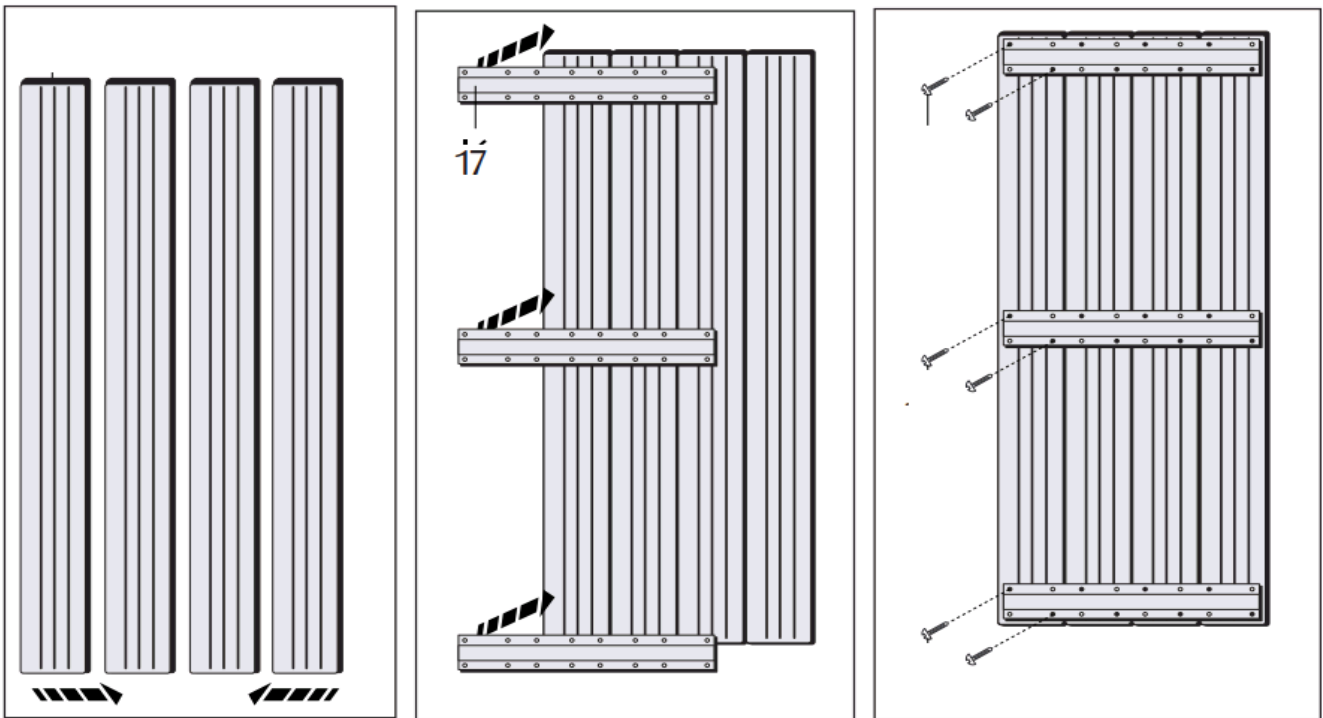

Fitting the ladder safety system

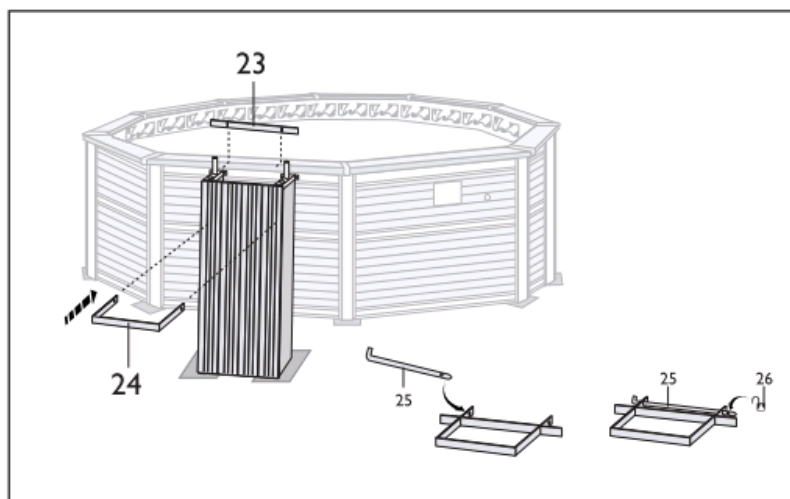
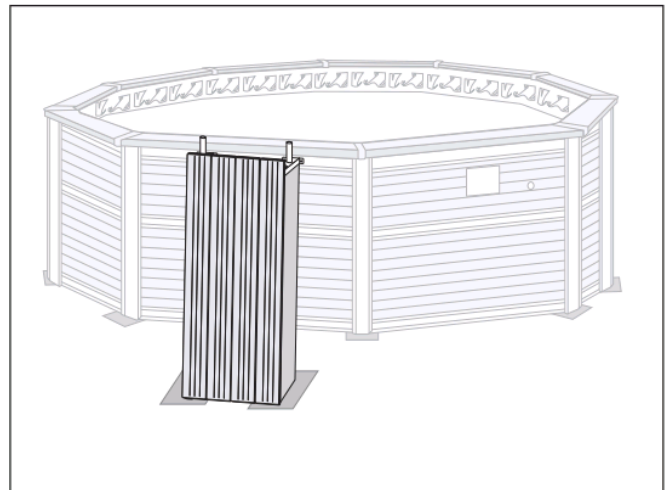
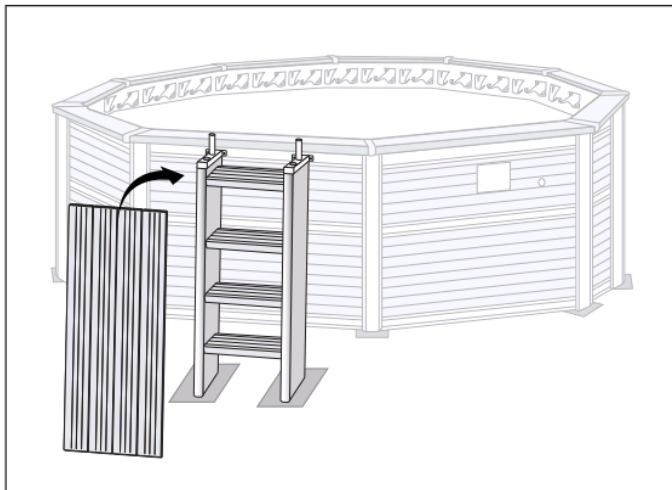

Last measurements for inspection purposes

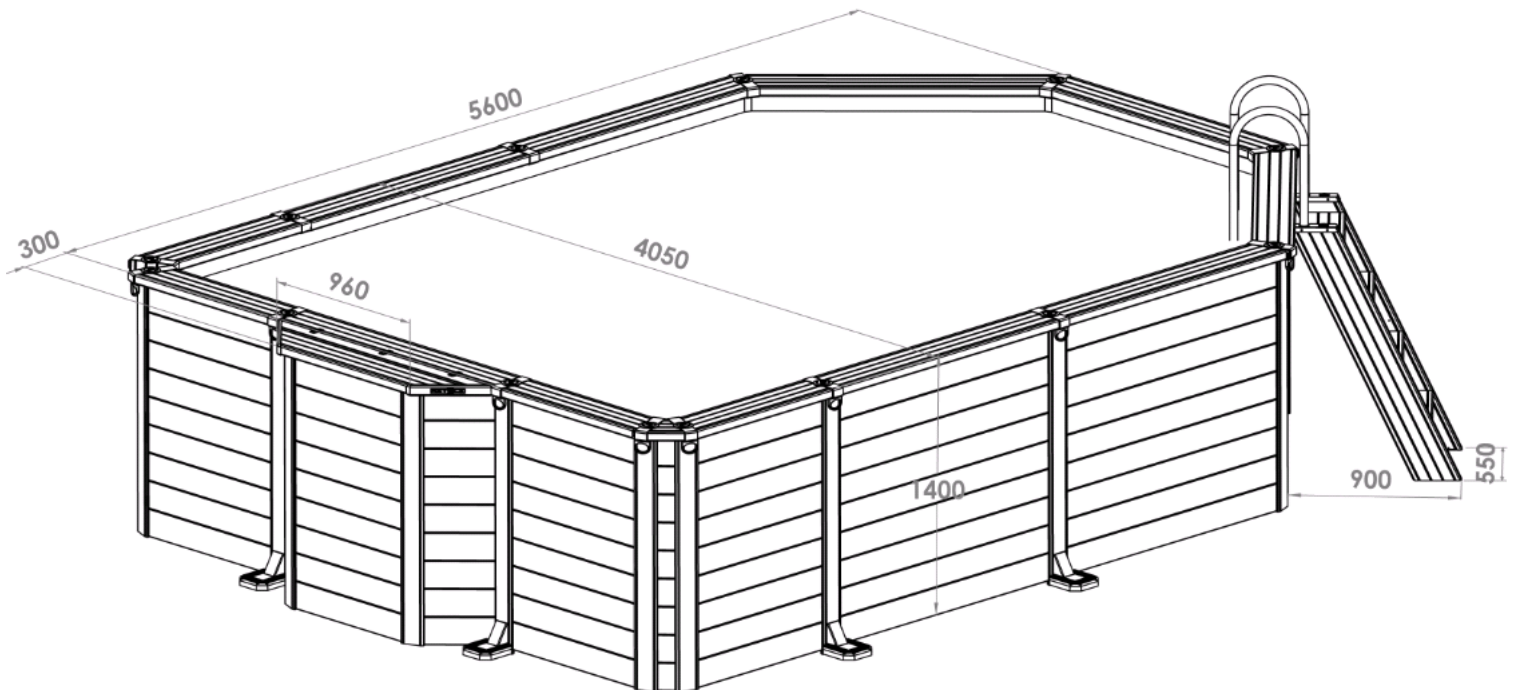

**AZTECK THANKS YOU FOR YOUR PURCHASE AND
WISHES YOU A GREAT TIME IN THE POOL**

SAFETY TIPS

A pool is a recreational place for fun and games but it also comes with hazards, especially for small children or anyone who does not know how to swim. To avoid accidents, simple cautionary tip should be followed. As the pool owner, you have the most important role as it is up to you to restate pool safety rules to users.

Never leave children who do not know how to swim without adult supervision. Never leave a child alone in the pool.

Never jump or dive in as the pool is too shallow.

For pools installed above-ground, access to the pool should only be allowed when the pool is under the supervision of at least one adult. If not, prohibit access by installing and locking the safety system on the pool access ladder.

Covering the pool with a heating or winter cover is not a safety measure (such covers are never considered safety covers).

Teach children to swim as soon as possible.

Never enter the water suddenly, especially after a meal (waiting for two hours is recommended) nor after exposure to the sun or intense effort as you risk a cold shock response.

Only fill your pool with mains water and use suitable treatment and maintenance products intended only for swimming pools. Always keep the water clean and chemically balanced.

Never leave a pet (dog, cat, fish or other) swim in the pool. Some of them may tear the liner with their claws and all of them may drown or asphyxiate.

A swimming pool is not a toy. Its use calls for care, supervision and maintenance.

Alcoholic drinks: Never use your pool if you have drunk alcoholic drinks or taken drugs or narcotics. A state of shock, loss of consciousness, a serious accident or drowning may result!

Safety barriers / alarm system:

A number of systems are available to reinforce preventive measures around a child and a pool. For pools installed above-ground, we encourage and recommend that you install a safety barrier and/or an approved alarm system. Note that for semi-inground pools, even if only partially so, and for fully-inground pools, this recommendation is a legal requirement in France following the law of January 2003 on protecting swimming pools.

Seek information from pool specialists and check the latest applicable laws.

Electrocution hazard: Never touch or attempt to repair an electrical appliance, including your filtration system when your body or the ground is wet. You could be electrocuted by a very high voltage: 220V / 230 V AC.

Keep your pool clean so that its bottom can always be seen. It is necessary to always see that the water depth is shallow and that no diving is allowed. This also ensures that a child under water may be seen immediately.

Never swim after dark, when you cannot see the bottom of the pool or read safety labels or messages. It is your responsibility to provide adequate pool lighting, to place safety labels and messages around your pool.

Refer to your electrician for this kind of installation and check that you are compliant with the applicable electrical regulations.

Never cut the framework of your pool to mount a floodlight or any non-original equipment accessory. The result could be serious inconvenience or even the release of a large quantity of water. This may cause the electrocution of those present and serious damage to both the pool and its surroundings.

Always use the ladder when exiting the pool and never climb the pool structure to exit it.

Never prepare your pool for winter with liquid chlorine. This will result in damage to the PVC liner that the manufacturer cannot be held liable for.

Always follow the recommendations made by the manufacturers of chemicals when storing, handling and using them.

Avoid installing any object around the pool that could make it easier to climb the sidewall for above-ground and semi-inground pools and/or anything that makes it easier to dive into an inground pool.

If the filtration system used is not the one originally offered and delivered with this kit, make sure that it complies with applicable electrical standards (refer to the filtration system instructions) and that it is suited to the volume of water to be treated.

For above-ground and/or semi-inground pools, do not apply excessive pressure to pool structure components such as kicking the framework, climbing or sitting on the structure.

Periodically check your pool and its accessories for any signs of deterioration and wear. Make sure that all components are in their proper place. Replace any damaged or worn component. Always use original spare parts from the manufacturer. Never modify your pool or its accessories without seeking advice from the manufacturer.

Some parts may come with a cutting edge or excess material following manufacture. Check whether any such edges can be found on pool parts, accessories or the filtration system. If there are any, you can eliminate them with sandpaper or a file.

Never lounge against, sit upon or climb the reinforcing frames of your pool (the finishing surrounds of your pool): you could damage them beyond repair.

Safety messages should be clearly visible all around the pool. Make sure that users can see and understand them properly.

In case of emergency, ensure that a lightweight, solid pole is available close to the pool along with the phone number for the nearest emergency centre, fire and medical services and the poison helpline.

Spare parts: Only use spare parts from the original manufacturer.

During the work to install your pool, keep children away until the installation work is completed.

IN CASE OF DROWNING:

Act immediately to remove the victim from the water.

In France, call:

Fire on 18, EMS on 15

and Law Enforcement on 17

ANY APPLIANCE SUPPLIED WITH 220 / 230 V MUST BE LOCATED MORE THAN 3.50 METRES FROM THE WATER. WITHIN THIS AREA, ONLY ELECTRICAL APPLIANCES OPERATING OFF A VERY LOW SAFETY VOLTAGE SUPPLY ARE ALLOWED

(Standard C 15 - 100 Section 702: 12 V= / 30 V AC).

Our additional safety tips

Your children's safety is your responsibility! The risk is greatest when children are under five! Accidents do not only happen to others! Be prepared to react!

Watch and act:

- Always ensure close and constant supervision of children,
- Make one person responsible for safety,
- Ensure additional supervision when a number of users are in the pool,
- Require the use of personal floatation equipment (for people who cannot swim),
- Teach children to swim as soon as possible,
- Wet the neck, arms and legs before entering the water,
- Learn first aid, especially to save children,
- Prohibit diving or jumping,
- Prohibit running and intensive play around the pool,
- Never allow a child that cannot swim properly to enter the pool without wearing a safety vest or flotation arm bands and without being accompanied by an adult,
- Never leave toys near the pool when it is not supervised,
- Always keep the water clean and healthy,
- Store pool treatment products out of reach of children.

Think ahead:

- Ensure that there is a phone to hand near the pool so that you never have to leave children unsupervised while on the phone.

Certain kinds of equipment can contribute to safety:

- Life ring and pole kept close to the pool.
 - A protection barrier with a gate that is constantly kept closed (e.g. a hedge cannot be deemed a barrier),
 - A manually or automatically operated protective cover properly placed and attached,
 - An electronic passage or fall detection system, in service and in working order.
- None of the above measures will ever replace proper close supervision!

In case of accident:

- Remove the child from the water as quickly as possible,
- Call the emergency services immediately and follow the instructions given,
- Replace wet clothing with warm blankets.

Remember and display close to the pool, the emergency services numbers:

- Fire (on 18 in France),
- EMS (on 15 in France),
- Poison helpline.

ALWAYS USE THE LADDER FOR
ENTERING OR EXITING THE POOL



NEVER DIVE



NEVER LEAVE CHILDREN
UNSUPERVISED



NEVER SIT OR STAND ON THE POOL
FRAMEWORK



TIPS FOR MAINTENANCE AND USE

Before starting any treatment we remind you that the pool should be filled with mains water (not rain or ground water, etc.). Here is a brief summary of chlorine water treatment methods. Do not hesitate to ask a water treatment specialist for advice. Failure to follow the maintenance instructions may cause serious health hazards, especially for children.

To ensure pleasant swimming as well as proper hygiene, it is important that the water remains clear, crystalline, transparent and bacteriologically pure. To ensure this, the water needs to be treated:

- **Physically:** through filtration and accessories
- **Chemically:** by using the right treatments

Physical treatment eliminates the particles suspended in your pool water. Chemical treatment is needed to sterilise the water and eliminate bacteria (algae and micro-organisms). **These are two complementary treatments that are essential to each other. You need to check and maintain your water daily.**

It is essential to periodically and systematically check that your water is being adequately treated and that your pool looks right. Tip: While the pool is in use, once a day and once a week the rest of the year.

PHYSICAL TREATMENT

The total volume of water in your pool needs to be recycled in full at least once a day. **Theoretic filtration time = Water volume / Pump system* flow rate (cubic metres per hour).**

* system flow rate = the flow rate measured on the way out of the return pipe with the filtration system in working order, connected with 9 metres of piping and installed 3.50 metres away from the pool with its own filtration media.

The physical treatment requires the use of a filtration system suited to the total pool water volume and accessories like nets, brushes, robot cleaners, etc.

Do not hesitate to contact your distributor for information on the range of robot cleaner solutions available.

Remember that the filtration system must operate for **at least 8 hours a day** (preferably with 2 hours in the morning, 4 hours during the afternoon and 2 hours in the evening) for water at up to 21°C. If the water temperature is hotter, the filtration time should be increased.

There is no set rule, but the hotter the water, the longer the filtration time. For example, we recommend:

**Daily filtration time = Water temperature divided by 2.
(E.g. 24°C = at least 12 hours of filtration time).
Do not hesitate to run your filtration system.**

CHEMICAL TREATMENT

Important: All of the products used must be compatible with the PVC liner.

There are a number of different water treatment approaches available for your pool water, but here we will only cover chlorine based treatment.

Before starting, you will need a "pH - chlorine" test kit. This is essential for checking the chemical water treatment of your water.

Read and follow the instructions shown on the product before, during and after use. Follow the dosage levels and their compatibility with other products.

Avoid running the pump at night, for other than stirring the water, the chemical treatment duration is limited.

Do not hesitate to contact your distributor for information on the various pool maintenance solutions available.

Important: We formally prohibit the use of a salt water electrolyser for water treatment purposes (excluded from the warranty).

ESSENTIAL PRODUCT

1) Water acidity (pH: hydrogen potential)

For efficient treatment, water acidity (pH) should be between 7.2 and 7.6. Always check and adjust the water pH level prior to any operation. To do this, use a test kit and the appropriate products (pH - to lower the pH level and pH + to increase it).

2) Anti-algae treatment

To take preventive action against the development and proliferation of algae and fungus, use anti-algae products, algaecides - fungicides (product that should not be mixed with chlorine products).

3) Water sterilisation (chlorine)

Chlorine products are essential for destroying bacteria. Remember that the pH level modifies the proportion of chlorine truly active (that which kills bacteria). Always carefully follow the instructions in the checking kit and on the products.

Treatments to carry out:

a) Shock treatment for the water, performed when the water is filled and the pool returned to service using fast chlorine (generally chlorine in power or granulate form).

b) Permanent treatment with slow chlorine to maintain the chlorine level. Never allow direct contact between chlorine and the pool as it will harden, discolour and definitively damage the liner (excluded from the warranty).

GENERAL REMARKS

Always follow the indications provided on the product. Actual product dosage is based on:

- The amount of water to be treated in the pool,
 - Pool usage (number of people, more or less significant additions of interfering agents),
 - Weather conditions (stormy weather and water temperature call for regular adjustments to the chlorine level to avoid the water turning green; never put water on the product, always add the product to the water),
 - Always stir the water and wait until a product has had time to dissolve before adding another water treatment product.
- Allow some 12 hours between every adjustment made to the pH, chlorine or anti-algae treatment levels while running your filtration system. If you do not dismantle your pool every year, replace one third of the water every year and every 4 to 5 years, change all of the water.

Warning: Water is a living environment, hence water treatment calls for regular checking and maintenance work. Poor maintenance may lead to a proliferation of pathogenic germs, algae, bacteria, viruses, fungi, etc. that may change the water make-up, its colour and encourage the development of spots on the PVC liner that may prove impossible to remove (and excluded from the warranty).

Before and after use, always keep your pool products closed properly in a dry place, out of reach of children. Do not hesitate to ask for information on our product range from your usual distributor. Be sure to follow the instructions and the recommended dosage levels otherwise you may cause deterioration to the liner and the filtration system.

Never throw chlorine directly into the pool or into some skimmers (refer to skimmer instruction) as this could irreversibly discolour the PVC liner and cause it to become brittle (these events are excluded from the warranty) and this could also damage the filtration system. Ask your usual distributor for advice.

Use a chlorine float to ensure slow and regular chlorine block dissolution in your pool when it is not in use (make sure that the float cover is closed properly).

If the water in your pool is perfectly clear, with no chlorine smell, you still have to maintain its treatment using slow chlorine and an anti-algae product (**the chlorine level should be between 1 and 2 PPM and the pH between 7.2 and 7.6**).

Optional summer cover (or bubble cover)

Isothermal, these covers stop the water from evaporating and protect it from outside pollution (leaves, etc.). Made from bubble film, it captures the sun's heat while avoiding algae formation and excessive chlorine consumption. During the night, it reduces any heat losses.

Recommended accessories: Bubble covers, winter covers, nets, vacuum brushes, robot cleaners. Ask your distributor for help in choosing a compatible robot cleaner suitable for the characteristics of filtration system.

General

UV light plays an important role in the service life and colour retention of all of the pool's component parts. This is a normal phenomenon caused by the natural ageing of the elements that constitute the pool. Carefully and regularly clean all of the pool elements with a sponge soaked in a neutral pH soapy product.

Never use solvent based products or a high pressure washer (excluded from the warranty). Do not clean your pool in bright sunlight. Do not hesitate to ask our distributors about which products to use and for advice on their use.

Note: A lack of maintenance may leave indelible marks on pool elements, so wash it at least once a month. Special installation and maintenance conditions apply in areas with high humidity levels and/or where the soil is acidic and/or where the air is salt laden and/or corrosion levels are high (refer to our distributors for information). In areas with a tropical climate, refer to your local distributor for specific information on inspecting and maintaining the entire pool.

Liner maintenance

All of our liners comprise anti-cryptosporidium, anti-fungal and anti-UV treatments and they are resistant to water with normal chlorine levels. To avoid liner deterioration, do not use any hydrocarbon (solvent) based cleaners.

Carefully and regularly clean the pool with a sponge soaked in a pH neutral product (do not use a brush, a high pressure cleaner as these are cases excluded from the warranty).

Do not clean your pool in bright sunlight. Do not hesitate to ask our distributors about which products to use and for advice on their use.

Note: A lack of maintenance may leave indelible marks on your pool (wash it at least once a month).

Proper liner conservation calls for continuous water maintenance (maintaining the proper pH level and steriliser concentration). The micro-organisms that develop if the water is not correctly treated will cause various stains and deterioration. As a general rule, PVC will discolour normally due to ageing. A number of factors may accelerate or retard natural PVC ageing.

1. Colour fastness

More or less rapid colour variations are linked to the use of sterilising products (oxidants). This is a normal phenomenon. Colours vary with the concentration of these products and pool usage. Local discolouring around the accessories (skimmer, return nozzles, etc.) may be observed. These are due to an excessive concentration of water treatment products.

2. Waterline

The waterline must be cleaned regularly to avoid various embedded deposits: scale, greasy products, etc. It should be cleaned carefully and regularly using PVC compatible non-abrasive products. Using organic solvents like acetone or trichloroethylene is absolutely prohibited.

3. Spots

In some cases, spots may appear on the PVC.

Pink spots:

These are bacteria that incorporate themselves into the material, grow and feed off the PVC.

Grey spots:

These are generally stains caused by a fungus outside of the waterproofing (in the case of wet ground) or due to polluted water.

Brown spots:

These result from a proliferation of algae or copper deposits (copper sulphate, electro-physical treatment processes, etc.). Whatever the case, always check the water acidity level (pH). If it is not right, correct it using pH + or pH -. Once the acidity level is back within the 7.2 to 7.6 range, shock treat the water while filtering for at least 24 hours. Before starting any treatment, do not hesitate to ask for information from an approved specialist.

The liner is designed to be resistant to corrosive agents. If even after all due care, you do accidentally damage the liner, there are two possible repair options:

1. Minor repairs (a small hole)

Using a repair kit that you can purchase from one of our distributors, you can make your own repairs to a small hole in the liner.

This kit contains:

- Liner samples,
- Glue for performing leak repairs, without having to empty the pool. If you need to make a repair, put a little glue on your fingertip and rub it over the hole. This glue only works in a wet environment: let the water drain from the hole as it will help the glue to set. If the hole is above the waterline, wet it abundantly while you spread the glue and maintain a slight pressure for a few seconds.

2. For a more significant repair (cut, tear)

If the liner requires major repairs: contact your distributor to determine whether it can be repaired. In this case, return it for repair after first carefully cleaning it both inside and outside and drying it fully. Mark the damaged part using an adhesive. Ballpoint pen marks are not permanent.

Also take a picture of it.

Metal component maintenance

Periodically check the metal parts that form your pool for damage and natural wear and tear. Regularly maintain them by removing any signs of rust, then apply rustproofing. This inspection should be performed twice a year. Also ensure that the nuts and bolts are properly tightened and in place. The same applies to elements forming the ladders.

Maintaining pool stainless steel elements

Just like all stainless steel parts used in a nautical or swimming pool environment, these require monthly maintenance. This maintenance routine ensures that you can keep these parts without them showing any signs of oxidation (rust).

To perform this monthly maintenance, use products intended specifically for stainless steel. As your usual distributor for information.

Remark: For pools that are installed under a dome, for example, where considerable concentrations of chlorine emissions build up, maintenance should be performed more often. Never clean stainless steel parts with chlorine water.

To make maintenance easier, avoid any contact between stainless steel parts and chlorine water and wipe them off.

Composite component maintenance

Composite components require no special maintenance, simply cleaning them regularly with neutral pH soapy water is enough. Never use a high pressure washer, only a sponge. Mould may cause spots to appear. To clean them off, use a cleaning product that contains bleach. To remove grease or oil stains, use an off the shelf degreasing agent. We recommend always cleaning these spots as quickly as possible and if the spots persist, use a metal brush, but always remember to never use a solvent. If any scratches appear, simply brush them with a metal brush.

Note: The colour of composite components will change during the first months of their life and thereafter it will evolve slightly with time. This is a normal phenomenon.

Note: The panels surrounding the pool may deform (bulge) slightly if dampness persists (e.g. condensation). This is a normal and natural phenomenon. The copings will return to their initial shape after a few days of exposure to the sun, in the open air.

Note: Over time, composite parts often increase in size a little. This is a normal and natural phenomenon, when reinstalling the pool. If necessary, use a plane to re-adjust the assembly.

WINTERISING

- Check the pH and chlorine content of your pool. Adjust if necessary.
- Clean the bottom and the sides of the pool, and the waterline (using a product recommended by our distributors – never use a solvent based product).
- Pour a winterising product into the pool and mix it using the filtration system (for the winterising product and its dosage, refer to our distributors). The winterising product ensures that the water is protected during the winter: it is not antifreeze.
- Cap the one or more nozzles with a winterising cap (supplied with the filtration system).
- Drain your water circuit and disconnect the filtration and the pipes.
- Remove and clean the inside pool ladder (essential).
- Properly clean the stainless steel parts (link covers) using a specialist stainless steel product before fitting the winterisation cover (or you may find oxidation (rust) on these parts at the end of the winter).
- Essential: Always cover the pool with a winterisation cover.
For instructions on how to fit or use it, refer to its instructions.
- Store the filtration system, the pipes, after washing them with fresh water, rinse and dry them, before storing them in a dry, location that will not freeze. For filtration winterisation care: refer to the "Filtration" instructions.
Do not forget the pool accessories.

RETURNING THE POOL TO USE IN SPRING

If the pool requires reassembly: Follow the instructions from the start of this manual. If the pool is full: Remove the winterisation cover, clean it and use a surface skimming net to remove debris, leaves, etc.

Reinstall your filtration system, skimmer, replace one-third of the water, check the water pH level, perform water shock treatment and run your filtration system continuously for 24 hours. Test your water (refer to the water treatment heading). Clean the filtration media when necessary, vacuum up any debris laying on the bottom of the pool using a suitable pool vacuum.

GENERAL WARRANTY TERMS

FOREWORD

All of the dimensions and/or capacities of our pools are provided solely as an indication and these may vary with the various tolerances required during manufacture.

As the quality of our products is paramount, we reserve the right to change the characteristics of our models without warning.

All of our pools are sold ready for installation, whether above-ground, semi-inground or fully-inground.

The pool owner is responsible for:

- Carefully and completely reading the installation manual before locating the pool and for procuring every necessary or additional component required and if necessary, seeking information from someone approved by the manufacturer or one of their "affiliated

companies" prior to installing the complete pool.

- Choosing the land, location, layout, based on the constraints described in the installation instructions.
- Installing, using and maintaining the pool in compliance with the stipulations described in the installation instructions.
- Choosing treatment and maintenance products and their dosage, compatible with the pool's component parts (the maintenance that is called for at regular intervals is essential to safety, well-being and the proper operation of the entire installation).

If the owner wishes to have their pool installed professionally, we recommend that they contact a vendor approved by the manufacturer or one of their "affiliated companies".

1- GENERAL

We strive to fully satisfy our customers. Consequently, in France, in addition to applying the hidden failure warranty as defined by Articles 1641 and subsequent articles in the French Civil Code, we grant our customers a warranty that lasts for a duration relating to the relevant swimming pool modules.

2- WARRANTY BENEFICIARY

The warranty is granted solely to the first owner of the pool, i.e. the one who signed the original order for the pool and paid for it.

3- SWIMMING POOL MODULES

Under the terms of the warranty granted, the pool comprises four modules:

3-1 The "composite" module, i.e. the finishing around the outside of the pool made from "composite" components.

3-2 The "metal sidewall" module, i.e. the metal framework and structure that forms the pool.

3-3 The "liner" module, i.e. the single layer liner used to ensure the tightness of the pool.

3-4 The "other elements and accessories" module, i.e. all of the other elements that constitute the pool and that are not referred to in paragraphs 3-1, 3-2 and 3-3 above. The "other elements and accessories" especially comprise all of the accessories and peripherals such as filtration, ladder, skimmer, nozzle, etc.

4- WARRANTY COVERAGE

The warranty applies only to the modules described in paragraphs 3-1, 3-2 and 3-3 above constituting the brand new pool, i.e. the finishing ("composite" elements), the sidewall (framework and metal structure) and the liner made by WATERMAN.

The warranty applies so long as the modules were purchased from a vendor approved by the manufacturer or their "affiliated companies"****.

The pool warranty covers all manufacturing or material failures that may affect safety qualities within the limits of compliance with the conditions for location, installation, use, maintenance and safety as specified in the installation manual provided with each pool, and this subject to the following conditions:

4-1 "Composite" module

For this module and in the context of a compliant installation, the warranty is subject to conditions of normal use and periodic maintenance (refer to the instruction) and covers damage to the product in the following cases:

- Rot,
- Fungi,
- Insect attacks.

The warranty only applies to the colourfast nature of the composite element.

4-2 "Metal sidewall" module

For this module, the framework and structure (uprights, metal panels) benefit from a warranty against "perforation" caused by rust as part of a compliant installation, normal usage and periodic maintenance (refer to the manual).

4-3 "Liner" module

For this module, the warranty covers the soft PVC liner should it suffer from:

- Assembly (weld) faults and leakage,
- Premature ageing so long as the water is maintained in scrupulous compliance with the instructions for use and the procedure described by the manufacturers of the products used.

5- WARRANTY DATE OF EFFECT

The warranty takes effect from the day when the pool was delivered to the purchaser and who consequently becomes its owner.

This warranty cover will however be suspended if the agreed payments are not made on time. This suspension cannot have the effect of extended the warranty duration.

6- WARRANTY DURATION

6-1 "Composite" module: 10 years, with the following progressively reducing conditions:

During the first 5 years = 100% covered by the manufacturer

Years 6 to 10 = 50% covered by the manufacturer

6-2 "Metal sidewall" module: 10 years with the following progressively reducing conditions:

During the first 3 years = 100% covered by the manufacturer

During the 4th year = 70% covered by the manufacturer

During the 5th year = 60% covered by the manufacturer

During the 6th year = 50% covered by the manufacturer

During the 7th year = 40% covered by the manufacturer

During the 8th year = 30% covered by the manufacturer

During the 9th year = 20% covered by the manufacturer

During the 10th year = 10% covered by the manufacturer

6-3 "Liner" module: 10 years with the following progressively reducing conditions:

During the first 6 years = 100% covered by the manufacturer

During the 7th year = 80% covered by the manufacturer

During the 8th year = 60% covered by the manufacturer

During the 9th year = 40% covered by the manufacturer

During the 10th year = 20% covered by the manufacturer

7- WARRANTY TERMS

7-1 The warranty is voided by:

- Repairs performed by a third party not approved by the manufacturer or their "affiliated companies".
- Modifications and/or adaptations to the pool made without the approval of a person approved by the manufacturer or their "affiliated companies".
- Integrating or adapting parts and accessories that are not original and supplied by the manufacturer.
- Using the pool for any use other than the one it is intended for.

7-2 Pools are designed to be placed on the ground, whether on the surface, semi-inground or fully-inground. The manufacturer cannot in any case acknowledge as a manufacturing defect any rust attack affecting metal parts from the moment that they perform their function or any other consequences caused by a lack of periodic maintenance and/or the application of specific installation stipulations.

7-3 Using unsuitable products (household ones, copper sulphate, etc.) is strictly prohibited.

7-4 Using a water treatment system like a salt water chlorinator is strictly prohibited.

The manufacturer declines all liability and excludes from its warranty any consequences resulting from the use of these products. Beware of any excess or inadequate concentration when using certain treatment and/or maintenance products. Carefully read the product instructions for use and follow them. Refer to their manufacturers if you have any doubts.

8- WARRANTY CLAIMS

8-1 Only specialists who are recognised and accredited by the manufacturer or their "affiliated companies" are empowered to define whether a product can be deemed defective.

8-2 The warranty is limited to the replacement of the defective or damaged part as recognised by our specialists, or to its repairs, or its replacement with an equivalent part if it is no longer found in our range, and this at the discretion of our specialists. The defective part cannot trigger any kind of refund (refer to Warranty Application and Procedure below).

8-3 The manufacturer reserves the right to refuse to repair a pool or one of its component parts should it show excessive wear that may lead to hazards to pool users.

8-4 Regardless of the reason for the defect, the transportation costs and other related costs remain the responsibility of the owner benefiting from the warranty.

9- WARRANTY APPLICATION AND PROCEDURE

9-1 For any warranty request, please refer to the vendor where the pool was purchased.

9-2 Any request must be made with supporting evidence clearly showing the purchaser's name and address, the vendor's name, the date of product purchase and the precise model and type of pool.

9-3 The vendor will need to produce a warranty claim file to present to the manufacturer or their "affiliated companies" stating the cause of the alleged defect.

9-4 Any product that is deemed defective by our specialists will be exchanged or repaired, depending on the condition of the defect, at the sole discretion of our own specialists.

9-5 The cost of removing and refitting the part as well as any carriage costs will be borne by the pool owner.

9-6 If one of our specialists has to visit the site, and if it is found that the defect is not the manufacturer's fault, then the costs incurred by the one or more visits as well as the specialist's fees, will be invoiced to the ordering party.

9-7 Any immobilisation or inability to use the purchased item during the period required by the repair or the exchange will not lead to any loan of equipment and/or any right to any contractual compensation [for loss of use] of any kind whatsoever.

The immobilisation period [the loss of use] will extend the warranty duration by so much, on condition that the owner recovers their property as soon as they are informed of the end of repair work.

9-8 The owner is required to take every necessary measure to recover their property after all of the (repairs, inspections, assessments, etc.) are complete and this within a period of six months. After this time, we will consider that we have tacit approval to destroy the property and this without any reminder from the manufacturer or their "affiliated companies".

9-9 Every application will come with the Warranty Number. Without this Warranty Number, no traceability of our product will be possible and your warranty cover will be restricted to 2 years only (the legal warranty period).

10- GENERAL WARRANTY EXCLUSIONS

Items excluded from the warranty:

10-1 The 3-4 "Other elements and accessories" module especially comprising all of the accessories and peripherals such as filtration, ladder, skimmer, nozzle, etc.

Events excluded from the warranty:

10-2 All defects and/or issues that arise following inappropriate actions and/or natural wear and tear,

10-3 Any defect that arises due to poor positioning and/or poor locating and and/or poor installation,

10-4 Any defect that arises due to leaving a pool without water and/or poor maintenance and/or failure to comply with safety instructions, supervision requirements and/or the poor use of appliances or accessories or the use of equipment not recognised by the manufacturer as specially designed for an above-ground, semi-inground or fully-inground pool,

10-5 All ancillary, labour, travel, disassembly, packaging, transportation, immobilisation, cleaning assessment, reassembly costs as well as the loss or replacement of water, treatment chemicals, etc. linked to the replacement or the repair of parts recognised as defective by our specialists.

10-6 All damage:

- Resulting from the loss of water, excessive use of maintenance and water treatment products (chemicals) that are not compatible and/or not recognised by the manufacturer and failure to comply with the safety and oversight instructions, are all excluded from the warranty.
- Caused to persons and property by the use of water other than that distributed by the mains

AZTECK

water network, by ice, frost, thawing, fire, animals, vegetation, the environment, pollution, by natural phenomena (flooding, thunderstorms, storms, wind, ultraviolet light, etc.), vandalism, theft and fortuitous events, the type of ground, ground movement, ground collapse, ground collapse and ground drainage, are all excluded from the warranty.

10-7 All issues resulting from a poor choice of location or poor assembly, especially the following are all excluded from the warranty:

- Those resulting from a choice of location that is not clear and/or flat and/or on unestablished ground and/or on ground with residues of crushed quarry sand,
- Those resulting from poorly tightening all or a part of the nuts and bolts serving to assemble the sidewalls and/or the various structural components.

Specific exclusions relating to 3-4 "Liner" module

10-8 Snagging, tearing, punching, etc. as the result of incorrect handling or other causes.

10-9 Spots of all kinds and premature wear (certain chemicals, when mixed or used in excessive dosages may have a negative impact on the liner's service life, such as a loss of colour and/or a loss of the plastic coating causing the line to, in time, become porous, rigid and subject to breaking, as well as the consequences of major folds in places where said products concentrate. This is especially true for chemicals comprising isocyanuric acid and some products deemed to be chlorine-free except for pool purifiers based on active mineral molecules).

11- RECOMMENDATIONS

We recommend that the owner check with their insurance company that their civil liability towards third parties is covered, including as the owner of a swimming pool and that they seek information on the guarantees provided by their "insurance cover" after this acquisition.

*** Manufacturer = CF Group France - DEL SAS

Azteck, a brand



CF Group France - DEL SAS

ZA La Croix Rouge - 35530 Brécé - France

 @PiscineAzteck