

EN

INSTALLATION INSTRUCTIONS

INSTALLATION/CARE/MAINTENANCE/SAFETY INSTRUCTIONS



DEL 

LOCKING KITS

PUSHLOCK AUTOMATIC

CONTENTS

PLEASE READ THESE INSTRUCTIONS CAREFULLY AND KEEP THEM FOR FUTURE REFERENCE

Please read this manual carefully to help you understand all of the information and to ensure safe installation, use and servicing. We are not held liable for any damage arising due to a failure to respect the instructions set out in this manual.

DESCRIPTION.....	P.3
Components provided.....	p.3
Tools required for assembly.....	p.4
Packing list.....	p.4
Assembly.....	p.4
INFORMATION.....	P.5
Prerequisites.....	p.5
Elements.....	p.7
Locking kits.....	p.8
Fixation cavalier sur liner.....	p.10
Installation of the Pushlock automatic on the pool basin.....	p.11
Sealing fixation.....	p.23
Anchored front-mounted fixation.....	p.28
Electrical control box.....	p.34
Wiring the control box to the Pushlock and 230 V.....	p.36
Wiring the control box to the electrical panel.....	p.41
General information / calibrating the limit switches (motor DL & PL).....	p.45
After complete wiring.....	p.46
Programming mode.....	p.47
Adjustment of the automatic switch (current monitoring).....	p.48
Automatic mode.....	p.50
USE.....	P.53
Handling the Pushlock Automatic front panel.....	p.53
First startup and inspection.....	p.54
Assembling the cover to the last slats.....	p.56
SERVICING/MAINTENANCE.....	P.59
Water level in pool.....	p.59
Info display (UNIBOX control box).....	p.60
Intervention and troubleshooting (UNIBOX control box).....	p.61
Spare parts.....	p.66
Troubleshooting guide.....	p.66
Warranty condition.....	p.67
SAFETY ADVICE.....	P.68
RECYCLING.....	P.70
Packaging.....	p.70
End of life.....	p.70

DESCRIPTION

COMPONENTS PROVIDED



	<p>Covers Pushlock automatic</p>		<p>Anchor to be embedded</p>
	<p>base Pushlock automatic</p>		<p>Anchored wall fixing</p>
	<p>Control box</p>		<p>U-bolt fixing</p>
	<p>Gel-filled splice device IP68</p>		

OPTIONS

	<p>Cable reel (Type 2 x 0.75 mm with 6 mm outer diameter)</p>
--	---

DESCRIPTION

TOOLS REQUIRED FOR ASSEMBLY



	Phillips screwdriver PZ2
	Screwdriver
	PZ2
	Concrete drill bit Ø8
	Wire stripper
	Flashed screwdriver 2mm
	Hex key T5
	Pointed marking tool

	Tape measure
	Pencil
	Mallet
	Cutter
	Open-end wrench 10
	Diagonal cutter
	Torx screwdriver T25
	T25 bit

PACKING LIST



1 package
package: 0.30 x 0.21 x 0.17 m
Weight in kg: variable

ASSEMBLY



2 persons



2 hours

PREREQUISITES



For clip fastening, the water level must be between:

- 7 cm minimum and 14 cm maximum for L69 and L84 slats

For embedded (to be sealed) fastening, the water level must be between:

- 7 cm minimum and above for L69 and L84 slats

For wall-anchored fastening, the water level must be between:



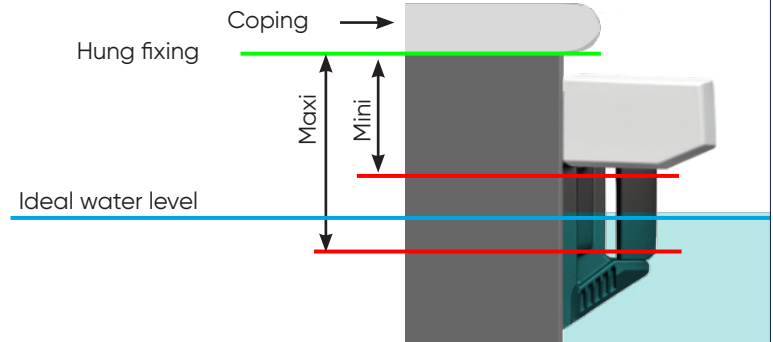

- 7 cm minimum and above for L69 and L84 slats

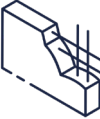

Check that the first slat can move slightly (1 to 2 mm) from right to left and, if not, slightly loosen the 2 screws and adjust the position of the kits by a few millimetres using the large oblong holes.

This will allow the triangular bar to rotate properly. If there is contact, the bar may not rotate, and the unlocking may therefore not be effective.

INFORMATION

	<p>Fitting the bolts and holding them in place is a major factor in the safety, so they should only be attached to a solid surface, such as concrete dosed at 350Kg/m³.</p> <p>Never attach to coping stones.</p> <p>Remember to plan site preparation: Create allowances (trenches for new installations or chases for renovation projects) between the technical room and each Pushlock automatic, up to the edge of the coping stones, for the installation of Ø40 mm electrical conduits.</p>
	<p>Remember to wear safety equipment.</p>
	<p>Warning: Activating the automatic switch is necessary for tear-out protection.</p> <p>The limit switches must be correctly adjusted (the slatted cover must be exactly in contact with the wall: no residual gap between the first slat and the wall, and no slats overly compressed).</p>
	<p>The recommended flexible 2 x 0.75 mm² cable is perfectly compatible with the supplied waterproof connectors.</p> <p>Standard rigid 2 x or 3 x 1.5 mm² cables are not properly secured in the connectors.</p> <p>Feel free to purchase our cable option, available in 20 m or 50 m reels.</p>

! WE RECOMMEND READING ALL THE INSTALLATION STEPS BEFORE INSTALLING THE SYSTEM, TO AVOID UNNECESSARY HANDLING.

INFORMATION

ELEMENTS

- Fixing method: as a rider on the pool edge (under the coping).
- The hanging kits are positioned on the width of the pool opposite the mechanics (the number and position vary depending on the pool configuration).
- These attachment systems are activated automatically when the roller shutter is opened or closed. The control unit gives the order for the attachment kits to pivot, analyses their status and then gives the order for the shutter to move.



Use of the automatic interruption (cut-off) system is mandatory, and using a PoolTerre and a water-level regulator is STRONGLY recommended.

Technical room

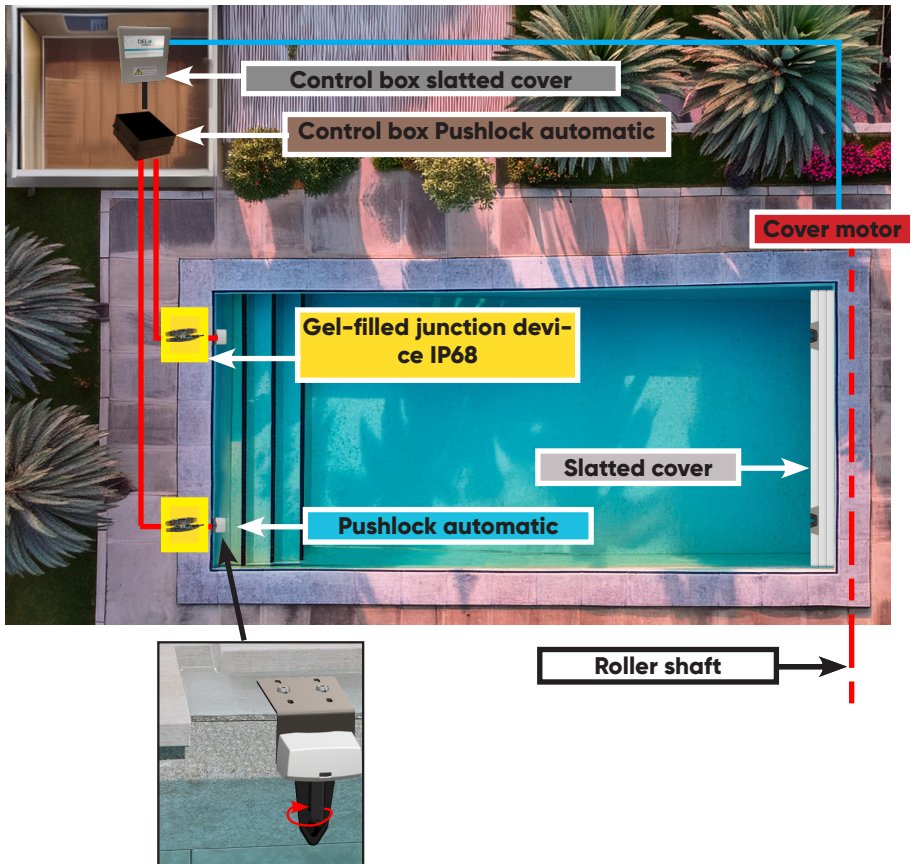

INSTALLATION

LOCKING KITS

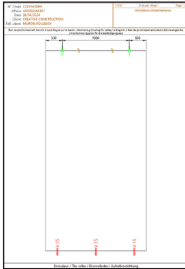

The positioning of locking kits in the pool is indicated on the drawing delivered with the slats.

All modifications to the positioning of the kits must comply with the rules explained below.

For all other cases, please contact us.

POSITIONING RULES

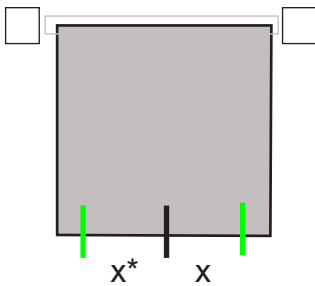

kit minimum 28 cm from the edge

kit 88 cm max. from the edge

additional kit



• The distance between 2 locking kits cannot exceed 3.24m.

INSTALLATION

4 FASTENING METHODS

Under-liner bracket fastening



On-liner bracket fastening



Built-in fastening

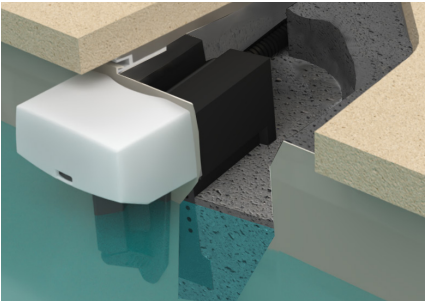

Anchored wall-mounted fastening

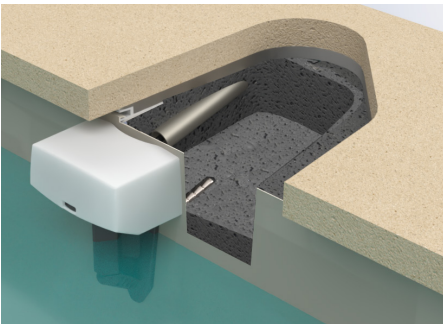

INSTALLATION

FIXATION CAVALIER SUR LINER

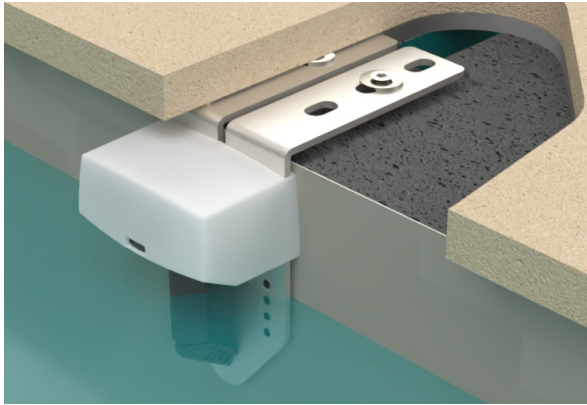

EXPLODED VIEW OF THE PUSHLOCK AUTOMATIC ASSEMBLY

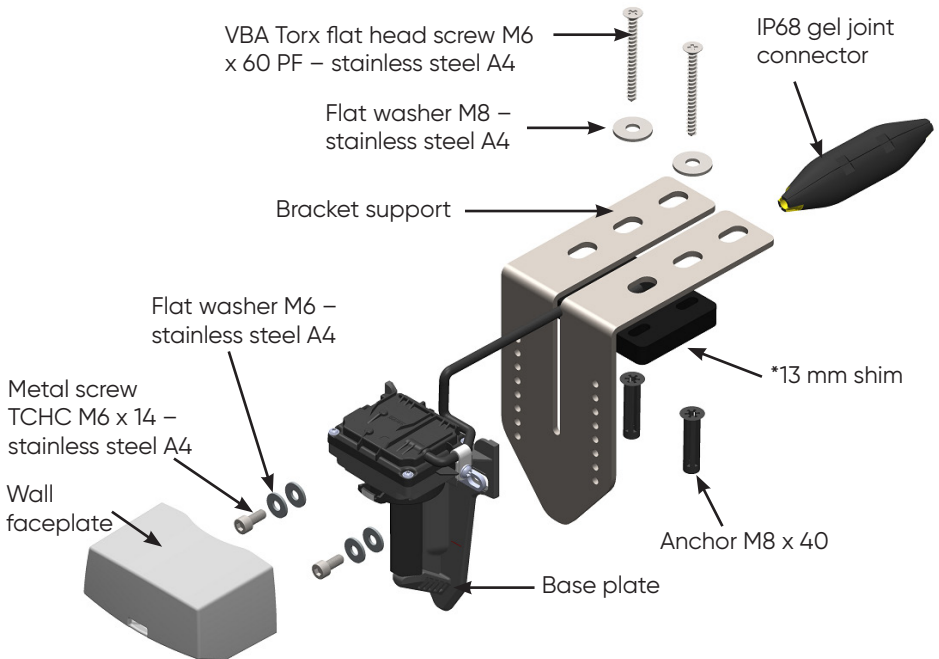

* The 13 mm spacer is optional, depending on requirements

INSTALLATION

INSTALLATION OF THE PUSHLOCK AUTOMATIC ON THE POOL BASIN

! A water level regulator is strongly recommended

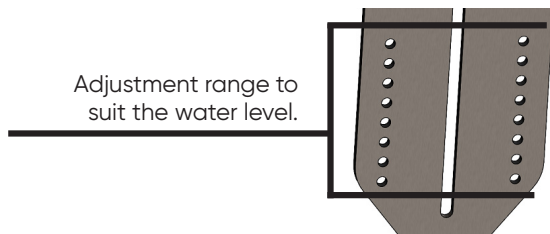

▶ STEP 1 – MARKING THE FIXING POINT

Place the base of the Pushlock automatic on the U-bracket support at the waterline as shown below.

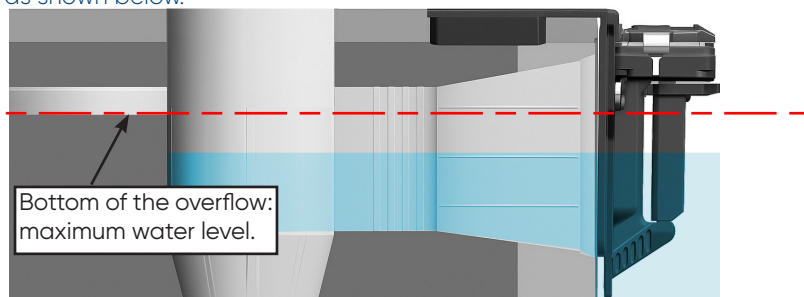

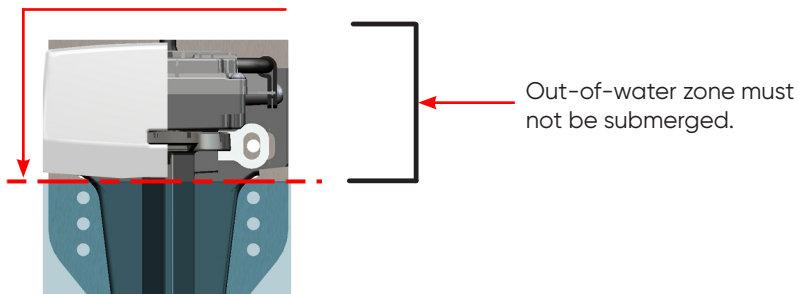

Check that the front of the Pushlock automatic does not touch the maximum waterline.



INSTALLATION

▶ STEP 2 – FIX THE BASES ONTO THE U-BRACKET SUPPORTS



	Metal screw TCHC M6 x14
	Flat washer M6

	Allen key T5
---	--------------

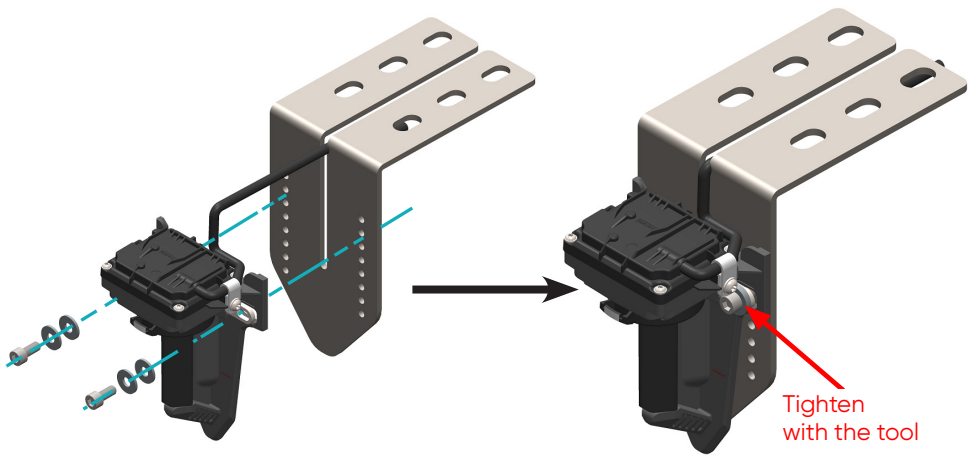

INSTALLATION

- **STEP 3 – PLACE THE SLATS WITH STAINLESS STEEL JAWS IN THE POOL ON THE SIDE OPPOSITE THE ROLLER**



- **STEP 4 – INSERT THE JAWS LOCATED ON THE SLATS INTO THE PUSHLOCK AUTOMATIC**

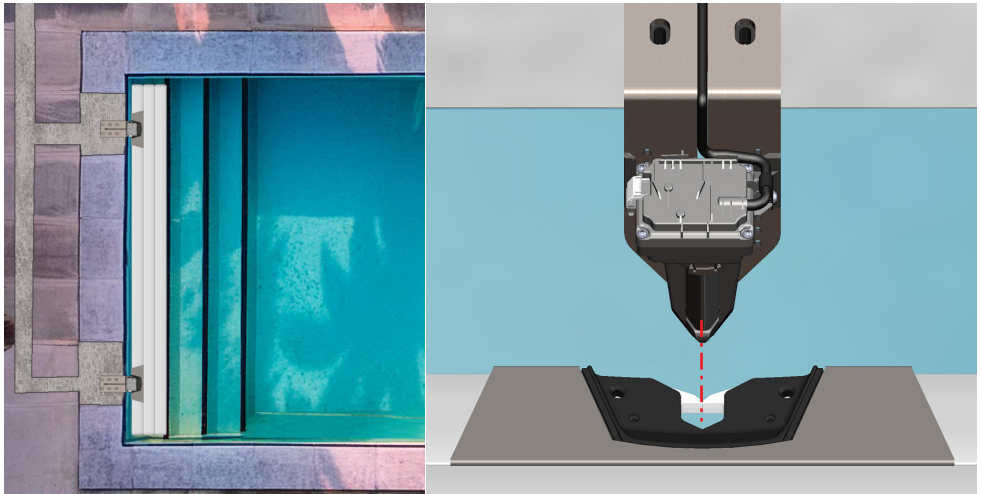

INSTALLATION

▶ STEP 5 – MARK THE POSITIONS OF THE U-BRACKET SUPPORTS ON THE CONCRETE DECK

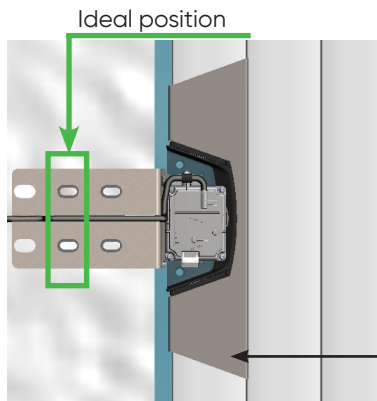

	Pencil
--	--------

Use the first slot as a template to precisely position the device.

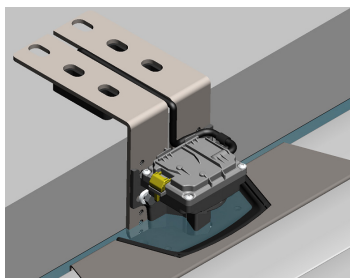

3 possible drilling positions:

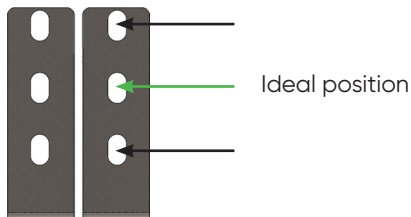

▶ STEP 6 – DRILL THE CONCRETE DECK



	Rotary hammer
	Concrete drill bit Ø8

INSTALLATION

STEP 7 – INSERT THE ANCHORS

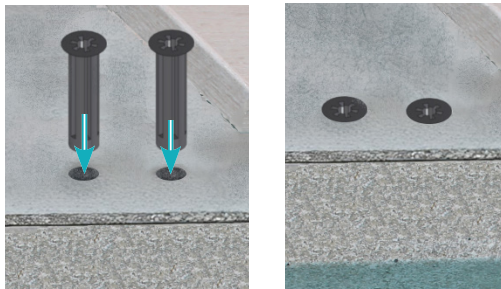



	Mallet
---	--------

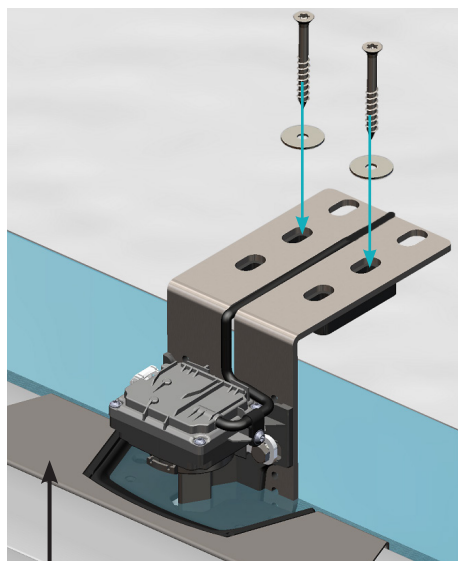

	Anchor M8 x 40
---	-------------------

STEP 8 – FIX THE U-BRACKET SUPPORTS

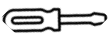

	Torx T25 screwdriver
	Screwdriver drill
	T25 bit



	VBA Torx screw M6 x 60
	Large was- her M8

Use the first slat as a template to precisely position the device.

INSTALLATION



EXPLODED VIEW OF THE PUSHLOCK AUTOMATIC ASSEMBLY

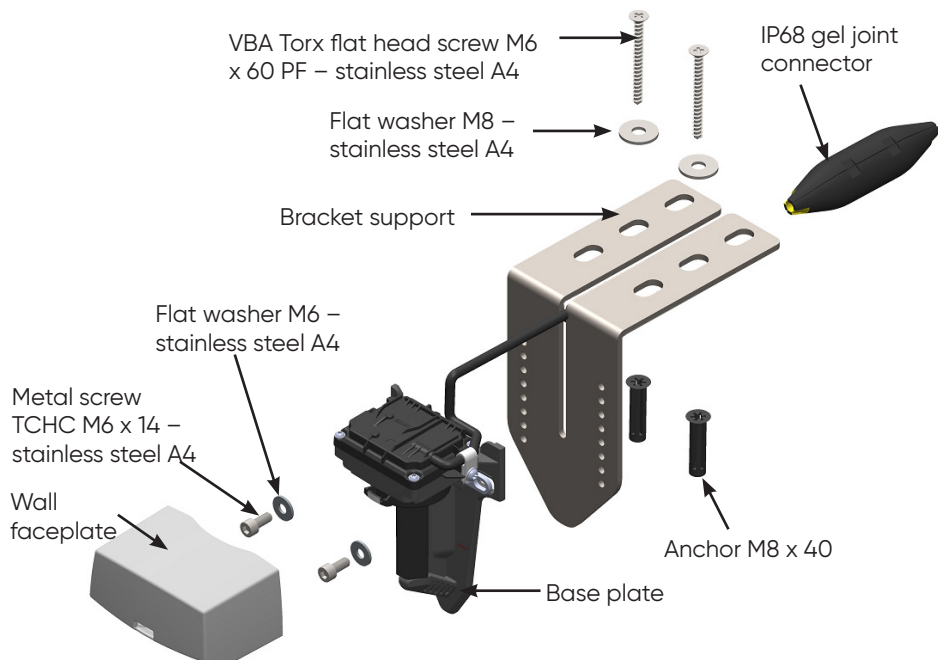

INSTALLATION

STEP 1 - CREATION OF THE BRACKET SUPPORT RECESS

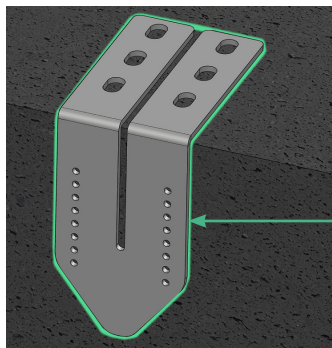

	Pencil
	Angle grinder

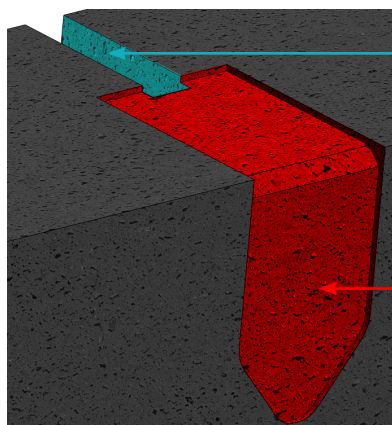

Space for cable and protective conduit

- Make a groove for the passage of the cable + corrugated protective conduit (not supplied).

Space for bracket

- Cut out the masonry on the coping and vertical face to a depth of 4 mm, as close as possible to the shape of the bracket.

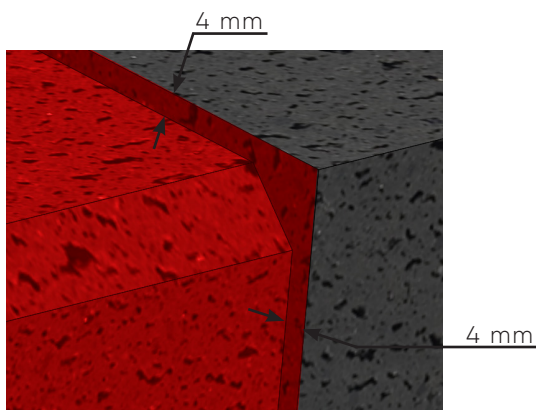

INSTALLATION

▶ STEP 2 – MARK THE POSITIONS OF THE U-BRACKET SUPPORTS ON THE CONCRETE DECK

3 possible drilling positions:

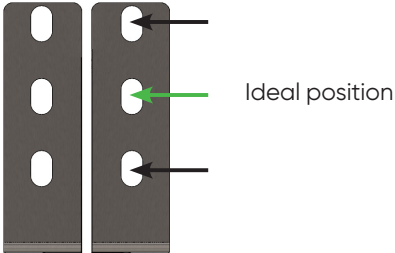

Pencil

▶ STEP 3 – DRILL THE CONCRETE DECK

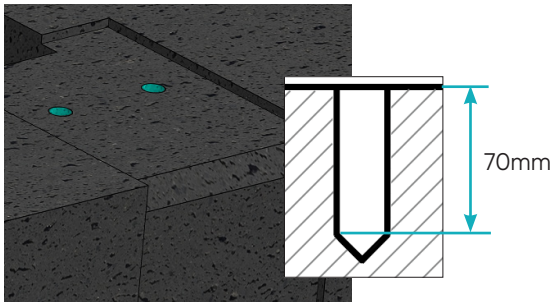

Rotary hammer



Concrete drill bit
bit Ø8

▶ STEP 4 – INSERT THE ANCHORS

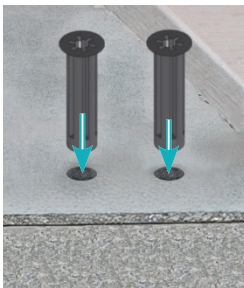

Mallet





Anchor M8
x 60

INSTALLATION

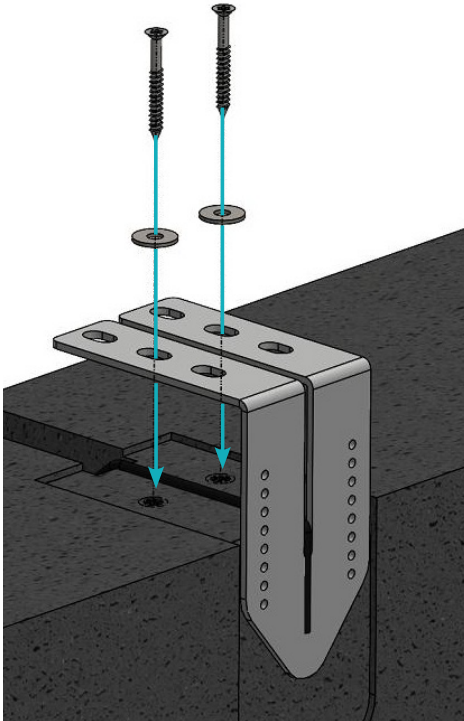
▶ STEP 5 – FIX THE U-BRACKET SUPPORTS

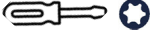

	Torx T25 screwdriver
	Screwdriver drill
	T25 bit



	VBA Torx screw M6 x 60
	Large washer M8

▶ STEP 6 – INSTALL THE HUNG TRACK AND THE LINER

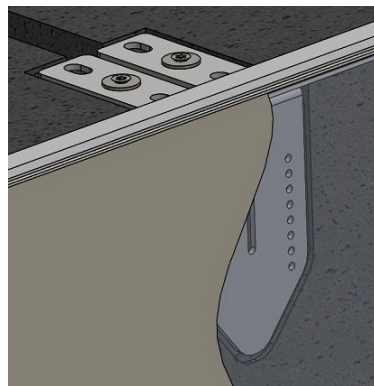
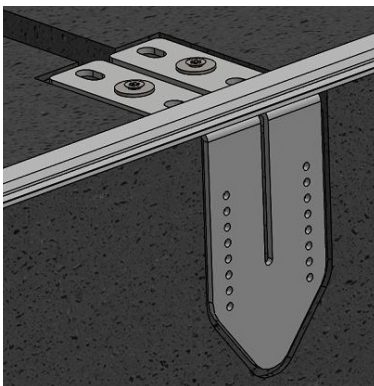

INSTALLATION

▶ STEP 7 – IDENTIFY THE FIXING POINTS AND THE MOTOR CABLE ROUTE

Place the base of the Pushlock automatic on the PVC membrane at the bracket support level, aligned with the future waterline as shown below.

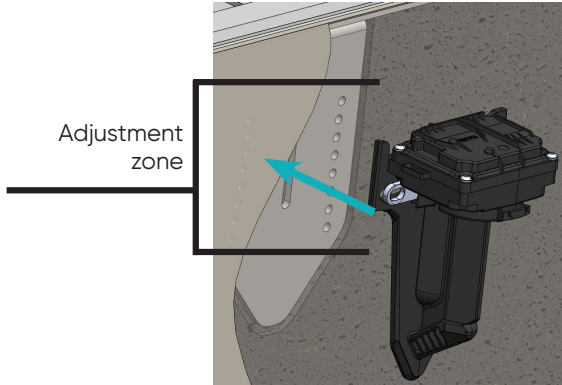

Precaution to be taken into account :

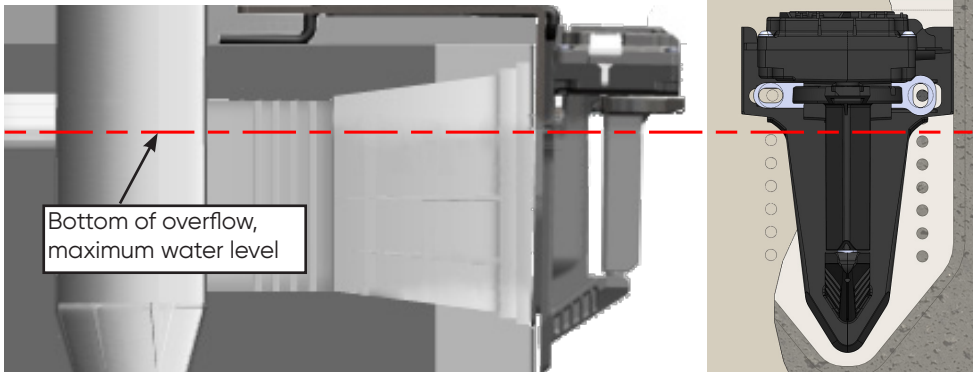

Ensure the front of the Pushlock automatic does not touch or go below the maximum water level.

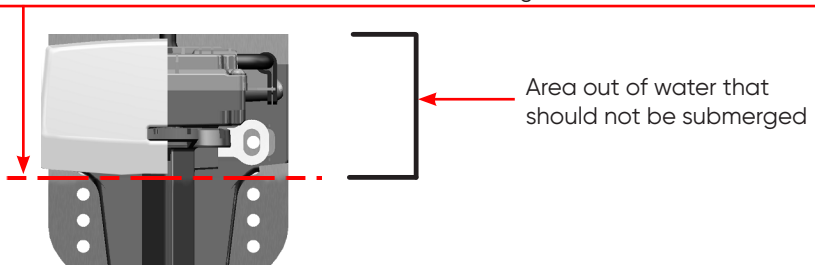

INSTALLATION

▶ STEP 8 – MARK THE PVC MEMBRANE AT THE PREVIOUSLY IDENTIFIED LOCATIONS

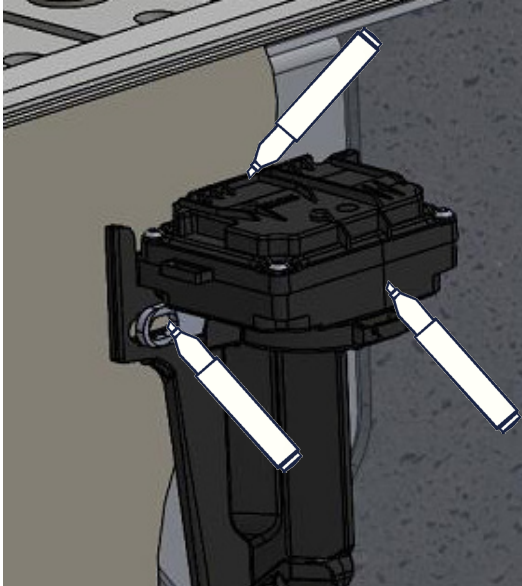

▶ STEP 9 – DRILL THE PVC MEMBRANE AT THE PREVIOUSLY MARKED POINTS

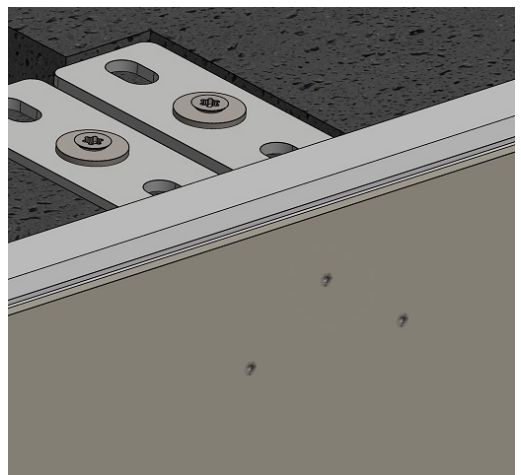

INSTALLATION

STEP 10 – MOTOR CABLE

1. Pass the motor cable through the PVC membrane.
2. Route it up through the vertical groove of the bracket support.
3. Route it through the horizontal groove of the bracket.
4. Into a protective sheath (not provided).

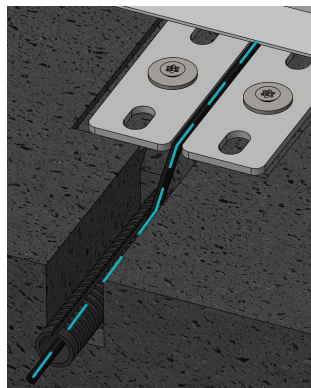
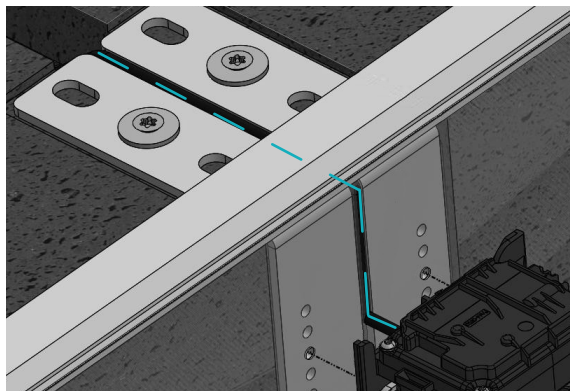

STEP 11 – FIX THE BASE

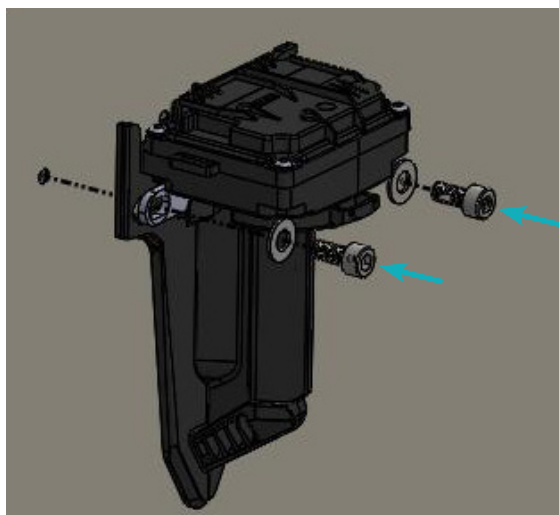

	TCHC metal screw M6 x14
	Flat washer M6



	Allen key T5
---	--------------

INSTALLATION

SEALING FIXATION

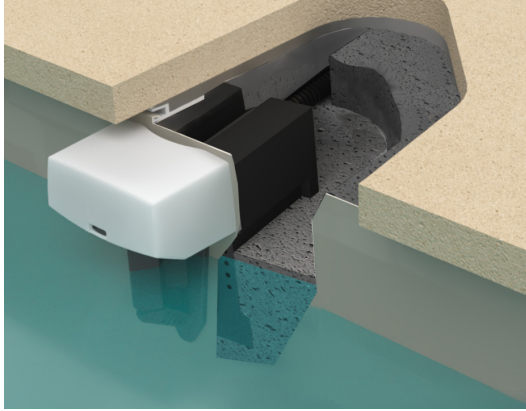

EXPLODED VIEW OF THE PUSHLOCK AUTOMATIC ASSEMBLY

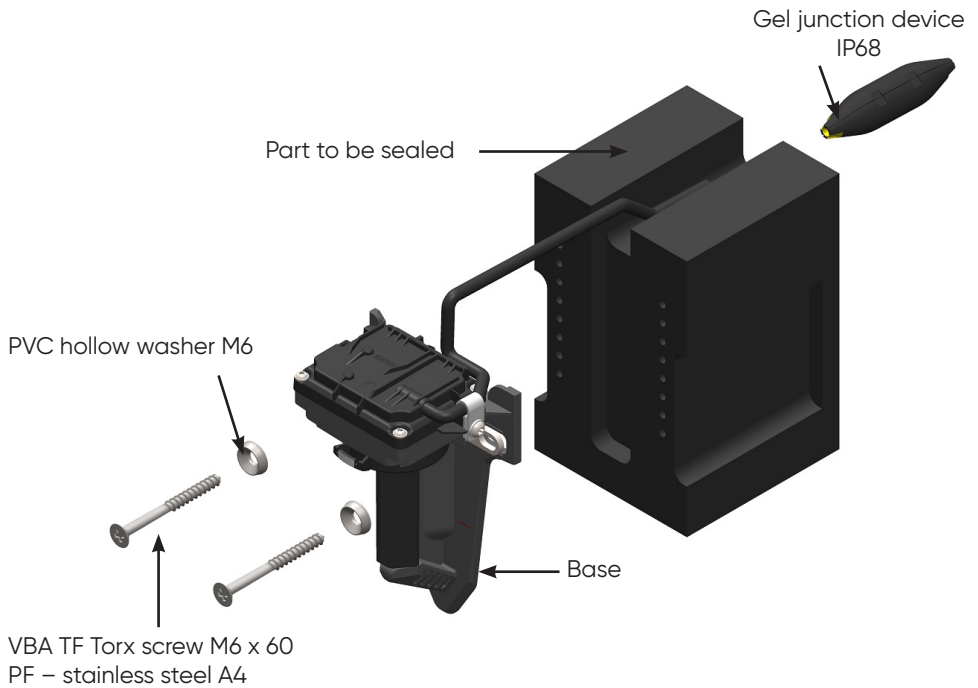

INSTALLATION

▶ STEP 1 – SEALING THE PVC PART TO BE EMBEDDED.

1. In the masonry, create a space for the PVC part to be embedded.
2. Create a groove for the motor cable and the corrugated sheath (not provided).
3. Seal the PVC part into the space created in the masonry.

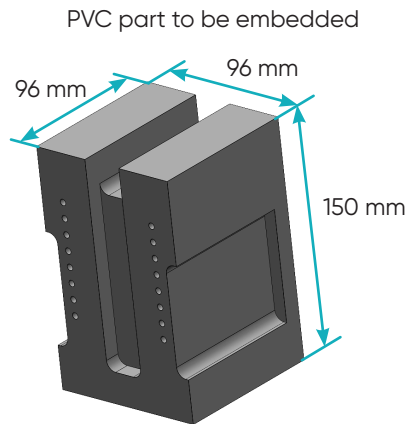
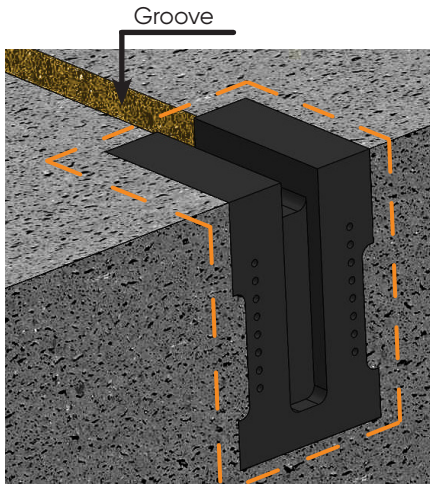

▶ STEP 2 – INSTALLING THE WATERPROOFING.

1. Install the hung.
2. Install the waterproof PVC membrane.

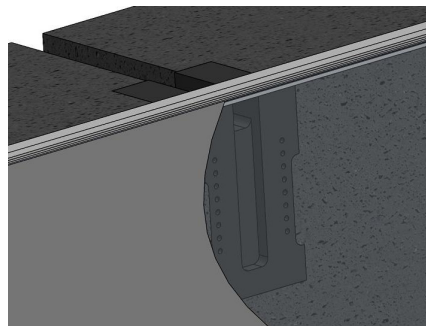
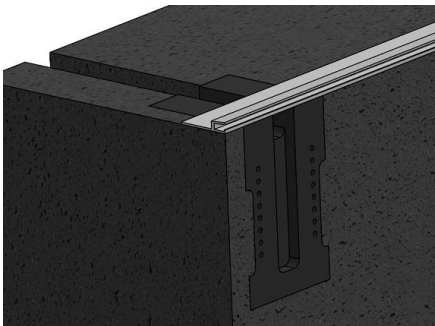

INSTALLATION

▶ STEP 3 – IDENTIFY THE FIXING POINTS AND THE MOTOR CABLE ROUTE

Place the base of the Pushlock automatic on the PVC membrane at the level of the part to be sealed, aligned with the future waterline as shown below.

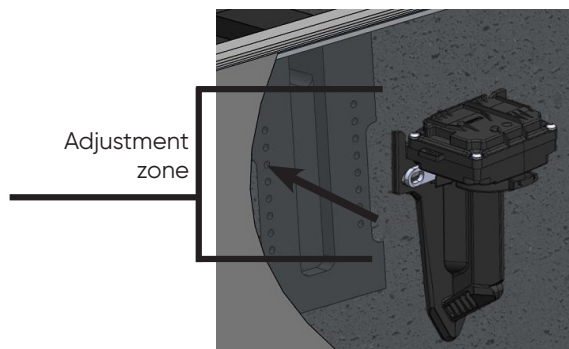

Precaution to be taken into account :

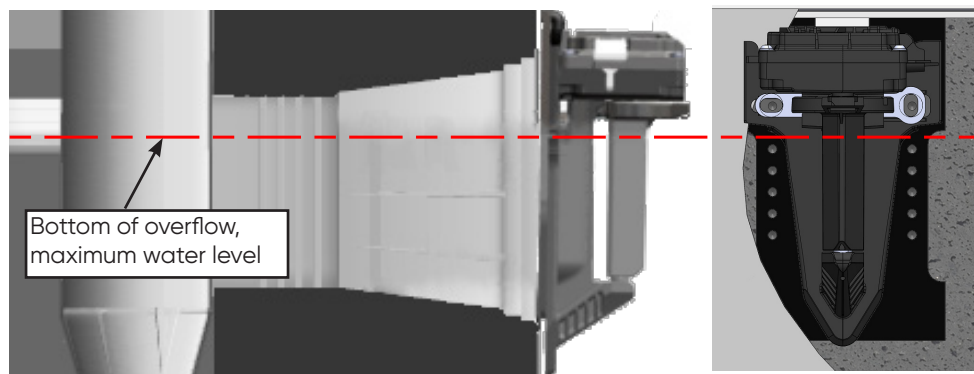

Ensure the front of the Pushlock automatic does not touch or go below the maximum water level.

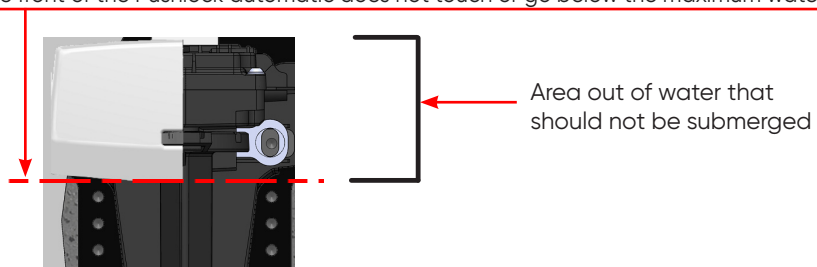

INSTALLATION

▶ STEP 4 – MARK THE PVC MEMBRANE AT THE PREVIOUSLY IDENTIFIED LOCATIONS

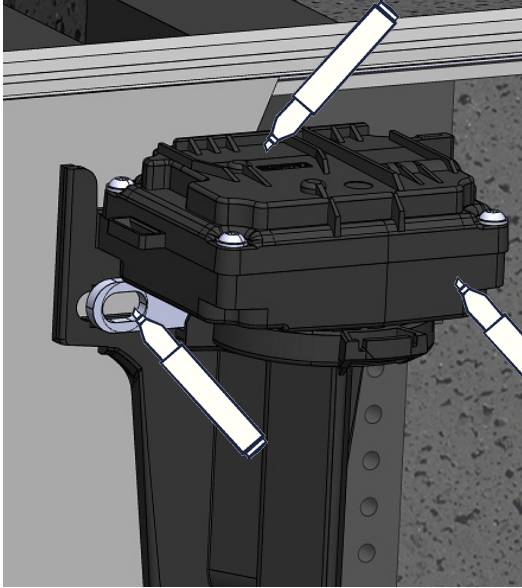

▶ STEP 9 – DRILL THE PVC MEMBRANE AT THE PREVIOUSLY MARKED POINTS

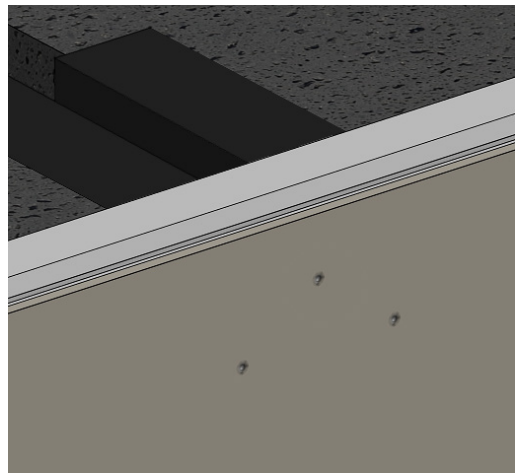

INSTALLATION

STEP 6 - MOTOR CABLE

1. Pass the motor cable through the PVC membrane.
2. Route it up through the vertical groove of the part to be sealed.
3. Route it through the horizontal groove of the part to be sealed.
4. Pass it through a protective sheath (not provided).

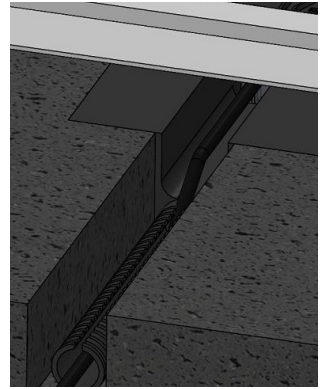
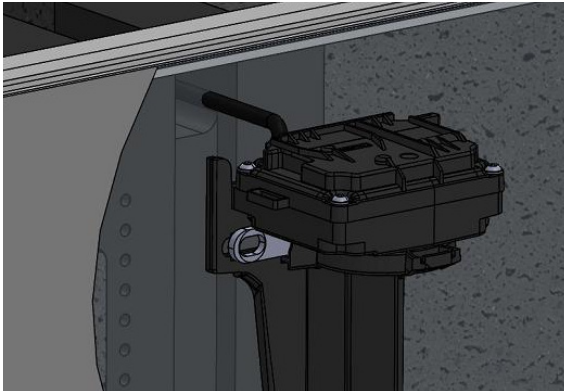

STEP 7 - FIX THE BASE

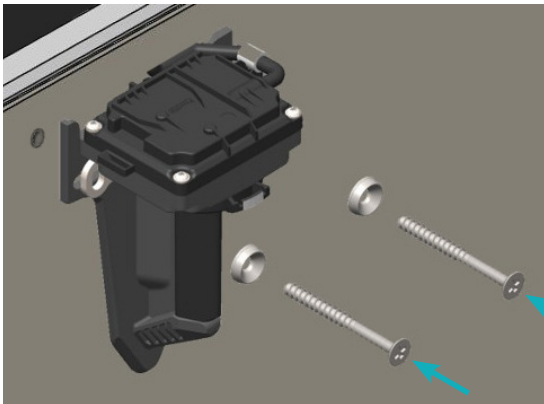

	VBA TF Torx screw M6 x 60
	Flat washer M6



	Torx bit T25
---	--------------

INSTALLATION

ANCHORED FRONT-MOUNTED FIXATION

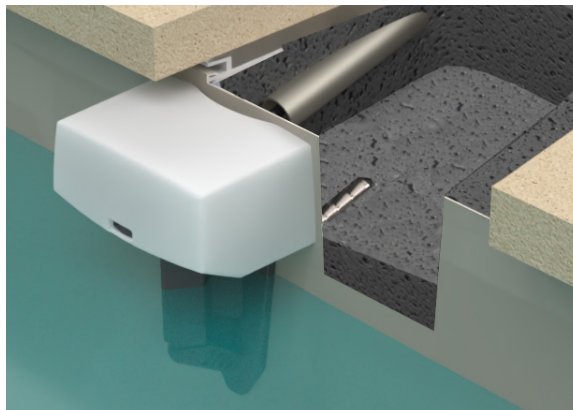

EXPLODED VIEW OF THE PUSHLOCK AUTOMATIC ASSEMBLY

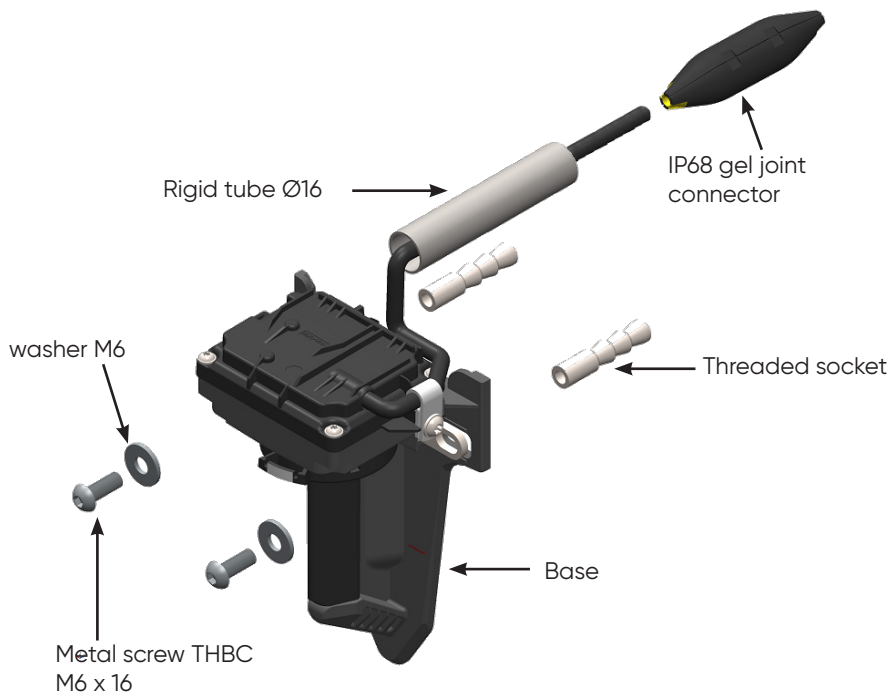

INSTALLATION

STEP 1 – IDENTIFY THE FIXING POINTS AND THE MOTOR CABLE ROUTE

Place the Pushlock automatic template on the PVC membrane at the level of the future waterline as shown below.

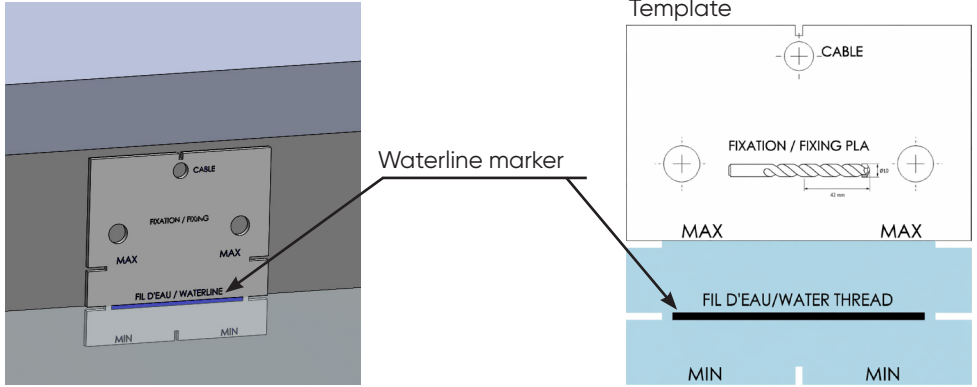

Precaution to be taken into account :

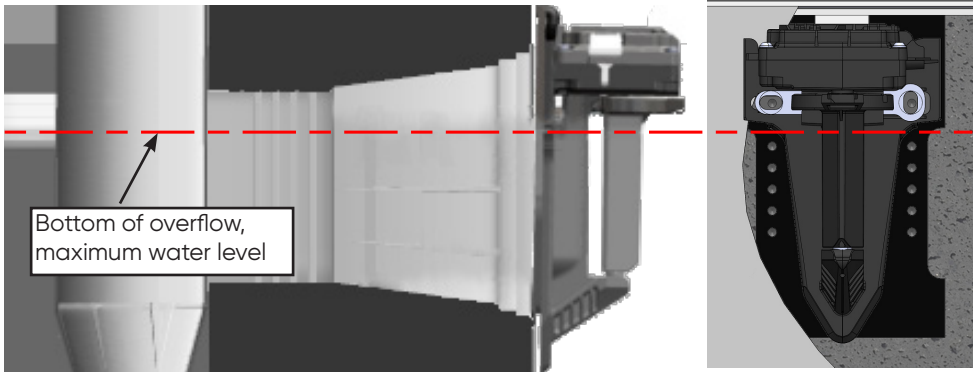

Ensure the front of the Pushlock automatic does not touch or go below the maximum water level.

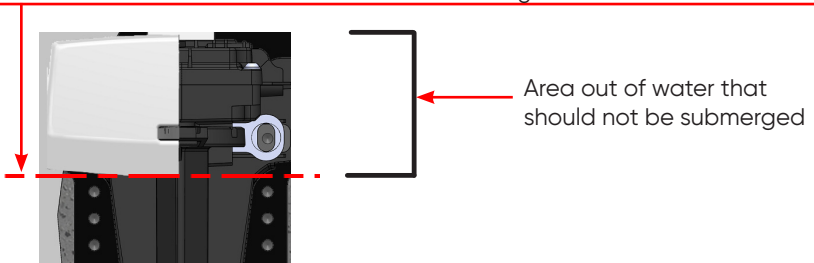

INSTALLATION

▶ STEP 2 – MARK THE PVC MEMBRANE AT THE LOCATIONS INDICATED ON THE TEMPLATE

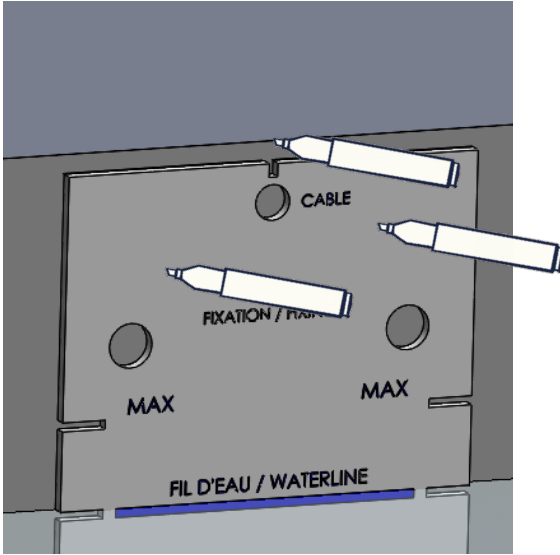



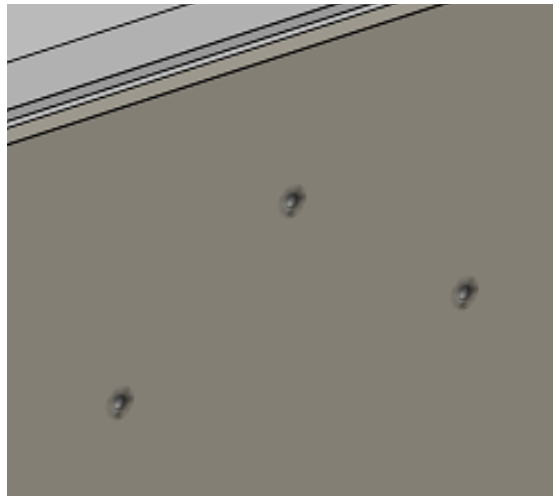

▶ STEP 3 – DRILL THE PVC MEMBRANE AT THE PREVIOUSLY MARKED POINTS

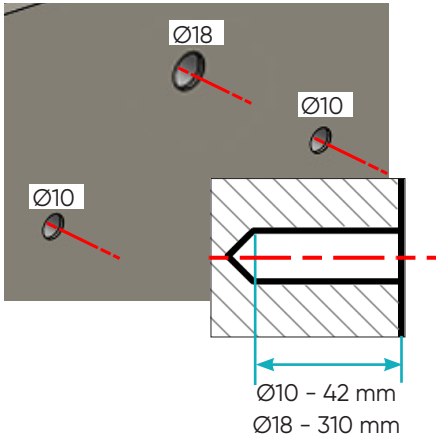

INSTALLATION

STEP 4 – DRILL THE WALL AT THE PREVIOUSLY MARKED LOCATIONS



	Rotary hammer
	Concrete drill bit Ø10
	Concrete drill bit Ø18

STEP 5 – CHEMICAL ANCHOR SLEEVES

1. Inject the chemical anchoring resin into the PLA fixing holes.
2. Insert the two chemical anchor sleeves into the holes, push them until they are flush with the membrane.

! Follow the product installation recommendations

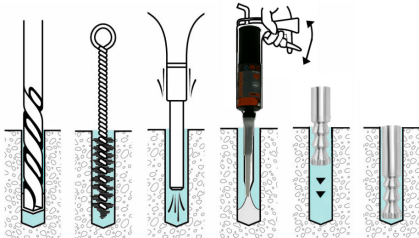

	Mallet
---	--------

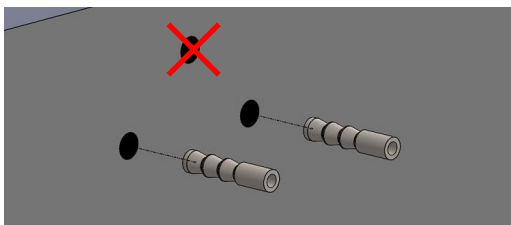

	Threaded sleeve TAR. M6-40/41
	Chemical anchoring resin

INSTALLATION

▶ STEP 6 – INSERT THE Ø16 TUBE

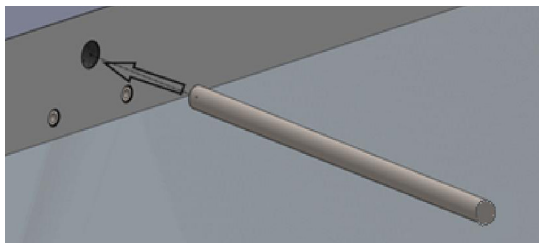

Sealant can be added to hold it in place.

▶ STEP 7 – PASS THE MOTOR CABLE THROUGH THE Ø16 TUBE

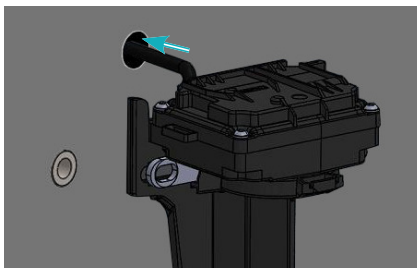

▶ STEP 8 – FIX THE BASE

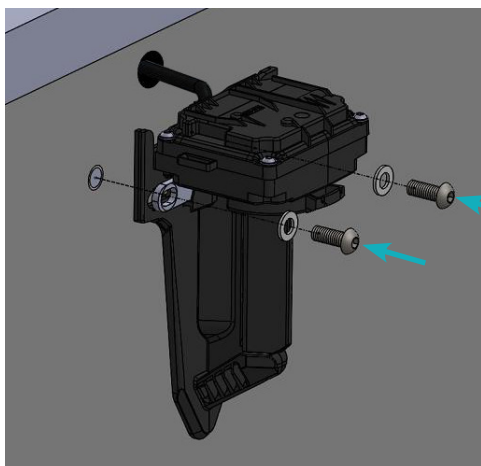

	Metal screw THBC M6 x 16
	Hollow washer M6



	Allen key T5
---	--------------

INSTALLATION

▶ STEP 9 – FINAL ADJUSTMENT OF THE BASES ON THE U-BRACKET SUPPORTS

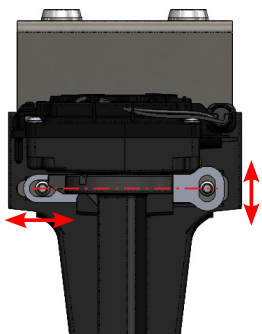

Once final adjustments are made, it is essential to firmly re-tighten all nuts to ensure stability and safety of the installation.

The stainless steel strip allows fine adjustment of the horizontal and vertical alignment of the Pushlock automatic base.

! The spacing between two devices must be as small as possible and less than 5 mm. Use the slot to assist you.

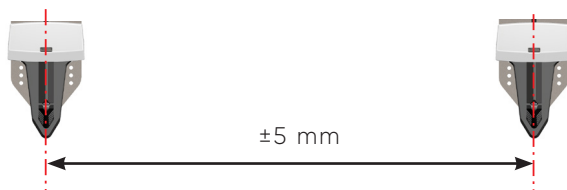

▶ STEP 10 – INSTALL THE FRONTS

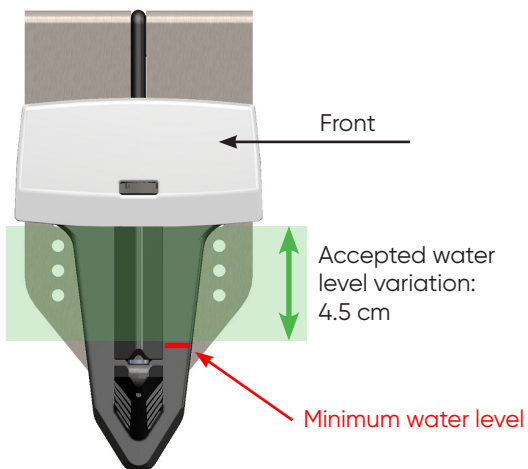
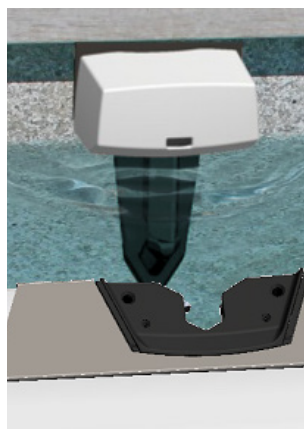

! A red mark indicates the lower limit of the tolerated water level.

INSTALLATION

ELECTRICAL CONTROL BOX

➤ MOUNTING THE CONTROL BOX

- The installation must be carried out in accordance with the electrical standards in force in the country of installation; in France in accordance with standard NF-C 15-100 (part 7-702), in Europe in accordance with standard HD 384-7-702 or equivalent in accordance with local regulations.
- The control box must be mounted on a wall in a frost-free technical room, away from rain, sunlight, any source of heat and any risk of it being sprayed or submerged, in an easily accessible location.
- It must be installed level, ideally between 1.2 metres and 1.5 metres above the ground, vertically, with the Câble glands facing downwards and on a wall that is sufficiently solid, flat and smooth to withstand the weight of the control box.
- The control box must be securely fixed to the wall using the screws and plugs supplied.
- Be careful if you decide to fix your control box by any other means, as the guarantee may not apply. Please note that adhesives are not considered a reliable means of fixing.

Note: Use the mounting template provided with the control box.

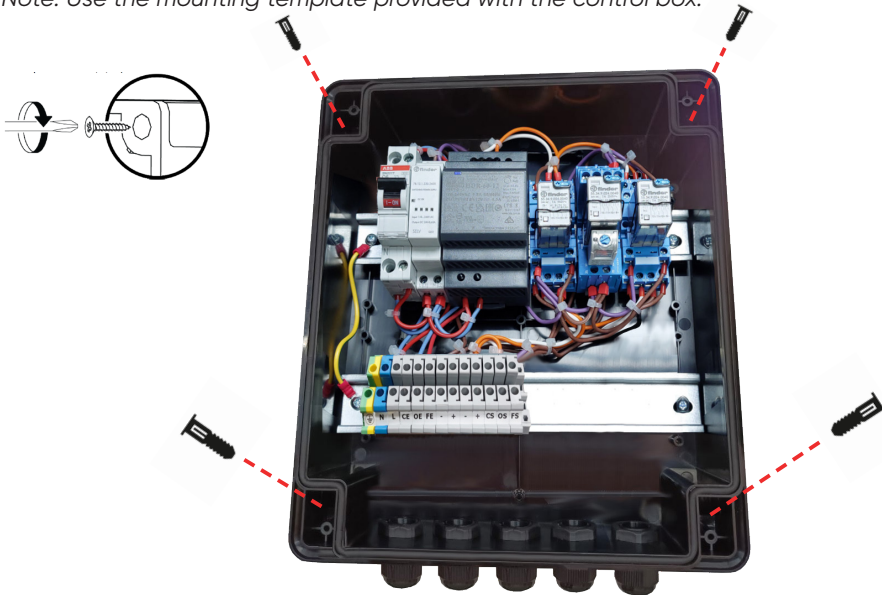

**No warranty if box is drilled.
If the enclosure is drilled, be sure to seal the fixings.
Use the fixings supplied with the box to maintain the IP rating.**

INSTALLATION

The electrical connection of the equipment must only be carried out by a qualified professional, and they must comply with the manufacturer's instructions in addition to the following applicable standards and regulations:

- NF C15-100: Low voltage electrical installations
- CEI 60364: Electrical installations for buildings

Please refer to the leaflet enclosed with the control box to ensure correct installation.



Incorrect installation may result in an electric shock, or it may even damage the equipment. We recommend that you disconnect the control box prior to any work being carried out on it.

Any specific electrical supply line must be protected by a 30mA circuit breaker along with a sufficient overcurrent protection kit.

We recommend use of shielded cable with a nominal cross-section that is not lower than the one indicated in the following table:

Current specified for the equipment A	Nominal cross-section mm ²
≤ 0.2	Flat twin tinsel cord a
> 0.2 and ≤ 3	0.5 a
> 3 and ≤ 6	0.75
> 6 and ≤ 10	1.0 (0.75) b
> 10 and ≤ 16	1.5 (1.0) b
> 16 and ≤ 25	2.5
> 25 and ≤ 32	4
> 32 and ≤ 40	6
> 40 and ≤ 63	10

NOTE: For power cables supplied with polyphase equipment, the nominal cross-section of the conductors is based on the maximum cross-section of the phase conductors at the end of the power cable that is intended to be connected to the terminals of the unit.

- a These cables can only be used if their length, as measured between the point where the cable or cable protector enters the equipment and the connection to the mains supply, does not exceed 2m.
- b Cables that have the cross-sections indicated in supports can be used for mobile equipment if their length does not exceed 2m.

INSTALLATION

WIRING THE CONTROL BOX TO THE PUSHLOCK AND 230 V

▶ STEP 1 – CONNECT THE IP68 GEL-FILLED JUNCTION DEVICES TO THE PUSHLOCK AUTOMATIC

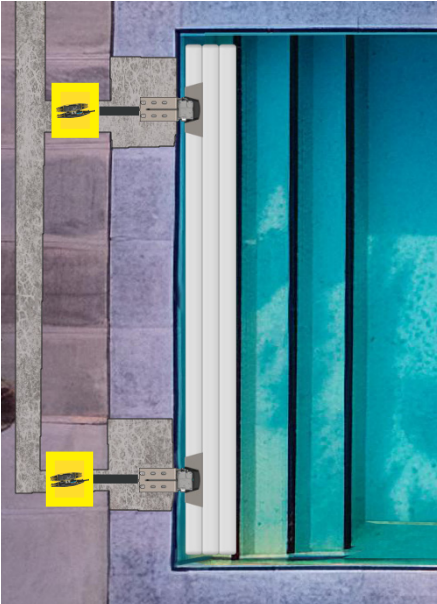

	<p>*IP68 gel-filled junction device</p>
	<p>Pushlock automatic</p>

*Use wiring method 1a – see the specific instructions included with the IP68 gel-filled junction device in its packaging.



- For optimal connection, strip the wires by 10 mm.
- Press the marked button (with a cross) using a finger or screwdriver, insert the wire, then release the pressure.
- Check by gently pulling the wires to ensure they are securely held.

INSTALLATION

Wiring the control box to the Pushlock and 230 V

▶ INSTALLATION AND MAINTENANCE PRECAUTIONS

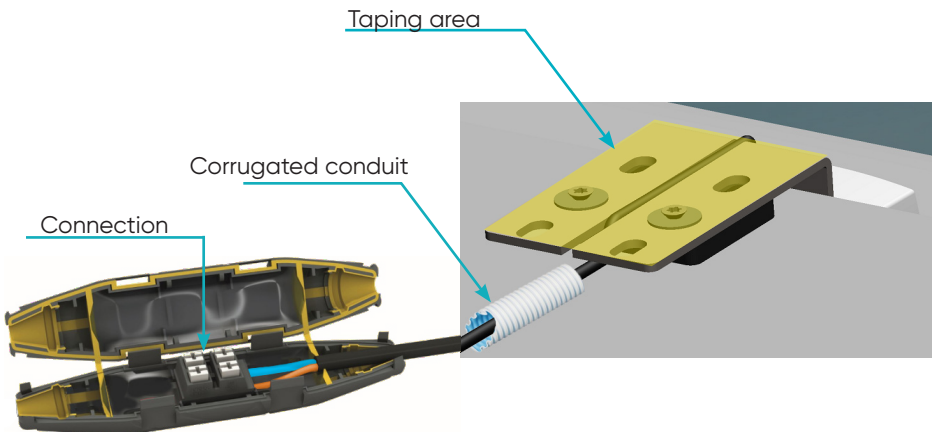

- We recommend routing the Pushlock Automatic cable through a corrugated conduit between the U-bracket support and the junction device. This precaution makes it easier to replace the cable in case of an issue, without having to remove or damage surrounding installations. It ensures faster and more efficient maintenance of the system.
- Before installing the coping stones, it is advisable to tape the top part of the U-bracket. This step prevents the support from being glued directly to the coping. In case the PLA or U-bracket needs to be fully replaced, this precaution allows easier intervention without damaging the installation.

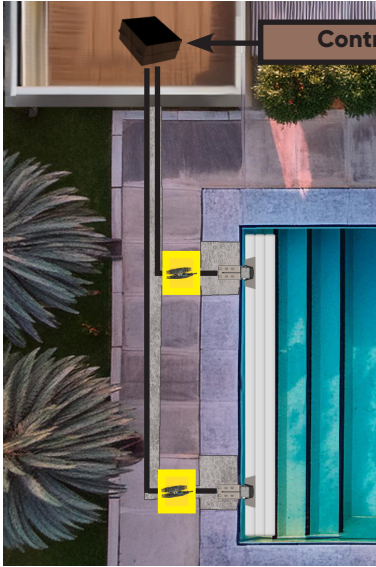

INSTALLATION

STEP 2 – CONNECT THE DEVICES TO THE CONTROL BOX

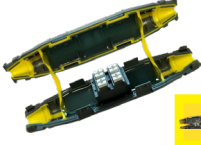

	<p>IP68 gel-filled junction device</p>
	<p>Control box</p>

If your installation includes more than 2 Pushlock Automatics, connect the junction devices to terminals M1 or M2

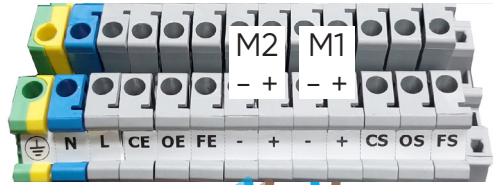

Example with a 3rd Pushlock Automatic

Connection

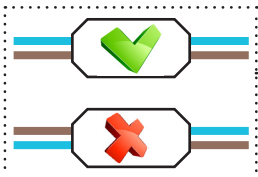

Observe polarity

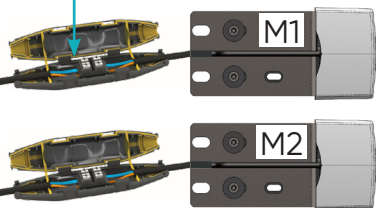

INSTALLATION

The cable connecting the junction device to the control box must be of type 2 x 0.75 mm² with an outer diameter of 6 mm.

We recommend using only this type of cable to ensure optimal compatibility with the electrical system and its waterproofing. This type of cable is available for purchase in 25 m or 50 m rolls.

Control box

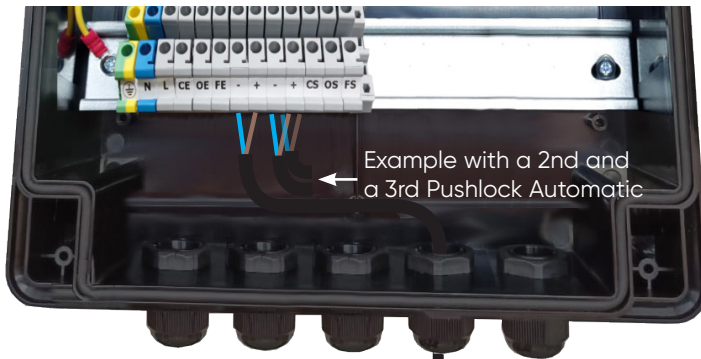

Cable connecting the junction device to the control box

(2 x 0,75 mm²)

Junction device



Each kit must be connected directly to the control panel.

INSTALLATION

▶ STEP 3 – CONNECT THE CONTROL BOX TO THE MAINS / 230 V

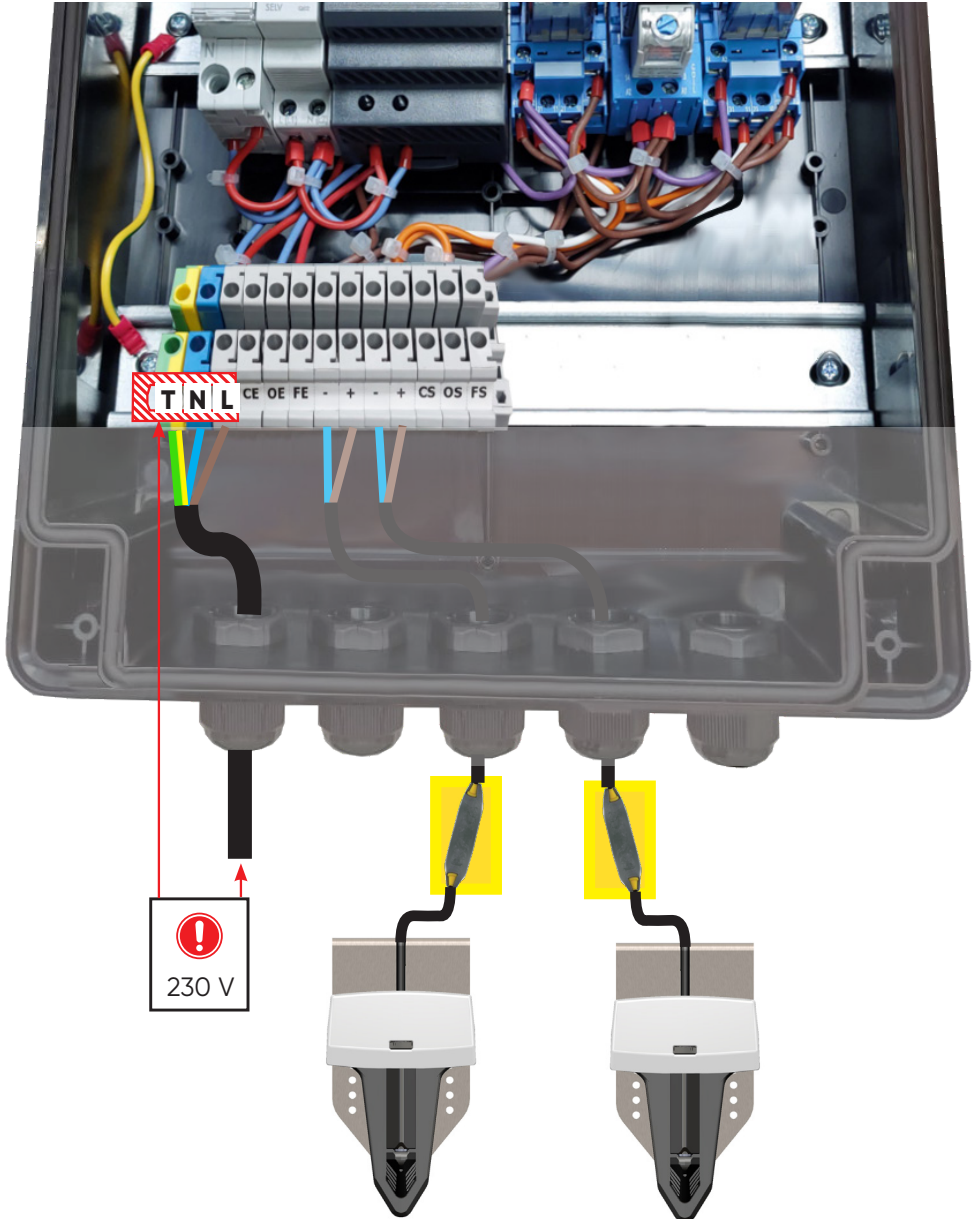

INSTALLATION

WIRING THE CONTROL BOX TO THE ELECTRICAL PANEL

- Make sure no one is in the pool during operation.
 - All connections must be made with the power turned off.
- ⚠ Depending on the electrical panel and control system you have, refer to the relevant wiring diagrams.

➤ WIRING THE WIKEY RECEIVER TO THE CONTROL BOX AND AN ELECTRICAL PANEL PL 1210/3210/5210/7210

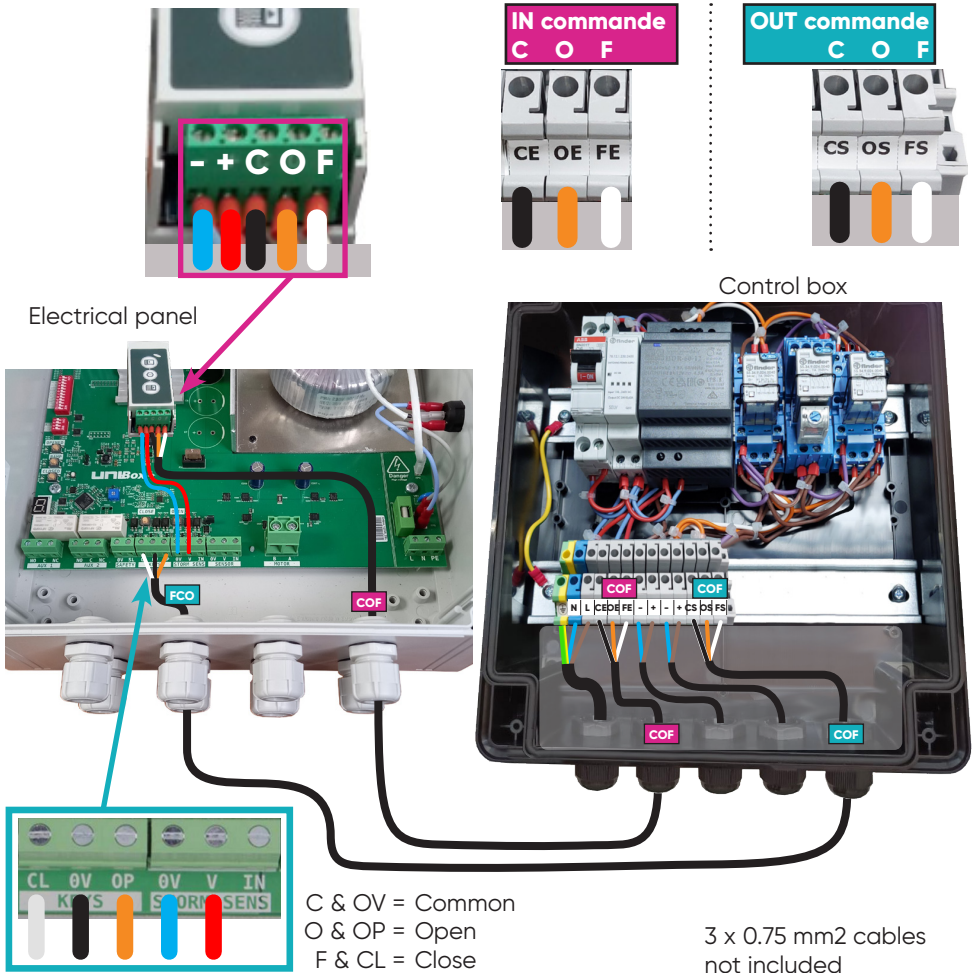

INSTALLATION

WIRING THE KEY SWITCH CONTROL UNIT TO THE CONTROL BOX AND AN ELECTRICAL PANEL PL 1210/3210/5210/7210

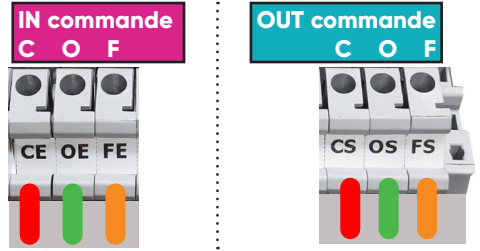

Control box

Electrical panel

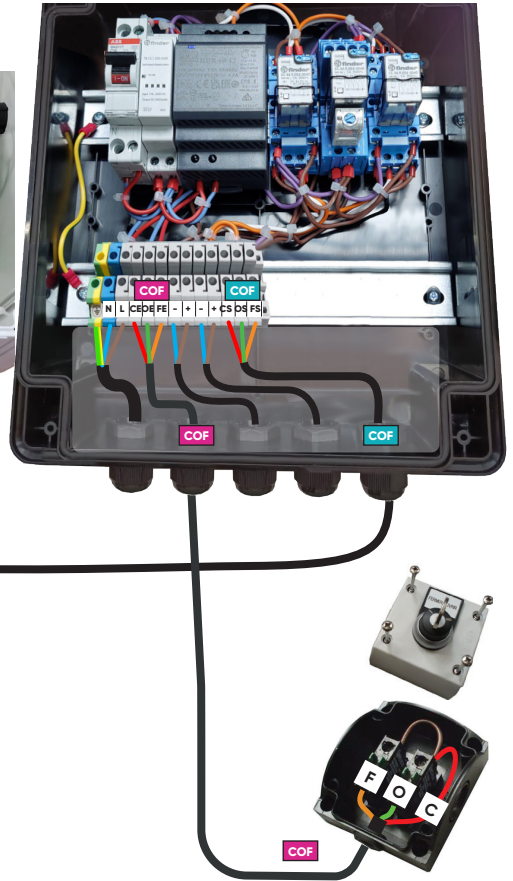
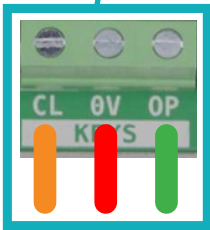
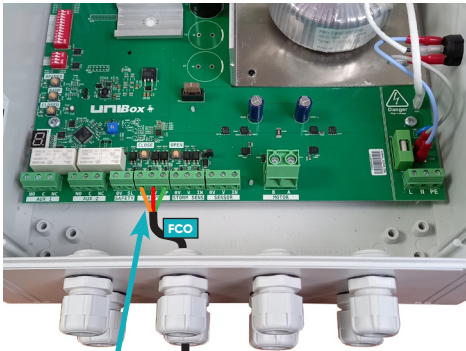

C & OV = Common
 O & OP = Open
 F & CL = Close

3 x 0.75 mm² cables not included

INSTALLATION

WIRING OF THE "SALT STOP" FUNCTION.

! The use of a PoolTerre is mandatory.

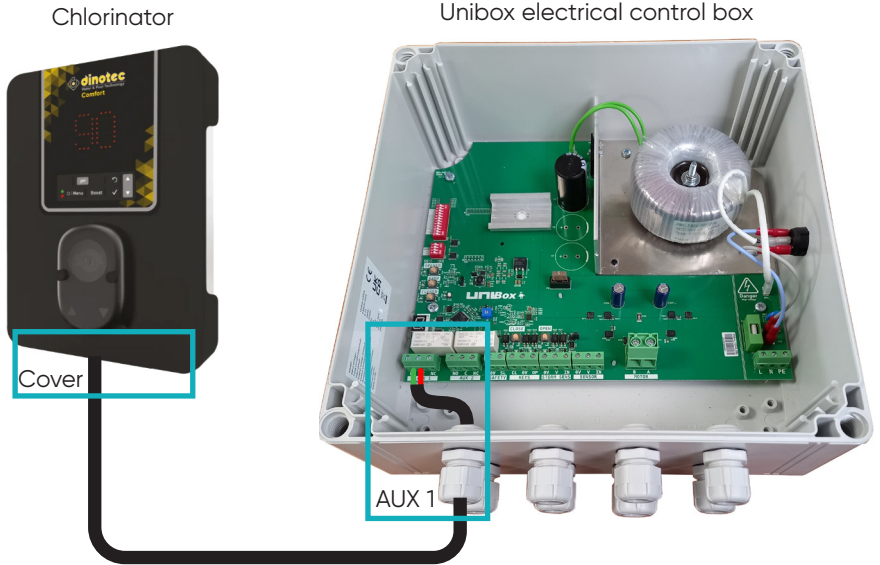

Note: Connecting the StopSel function is highly recommended when the automatic treatment device does not have a Redox probe.

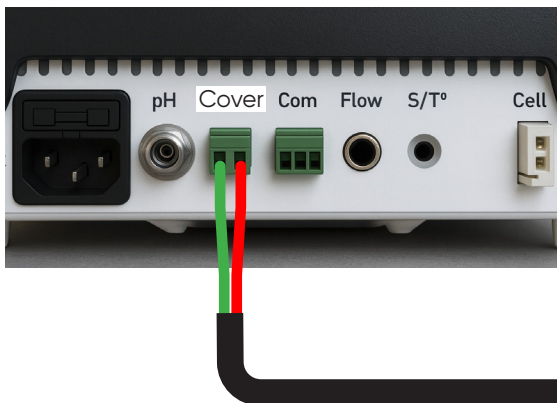

INSTALLATION

▶ STOPFLOW FUNCTION WIRING.

Note: Connecting the StopFlow function is highly recommended when water circulation interferes with the winding/unwinding of the cover.

Filtration box

Unibox electrical control box

Before

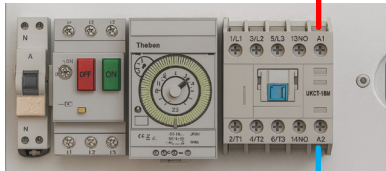

Motor contactor power supply

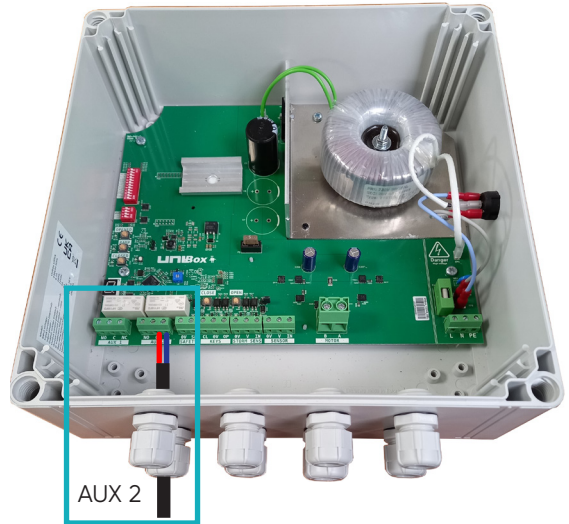

AUX 2

After

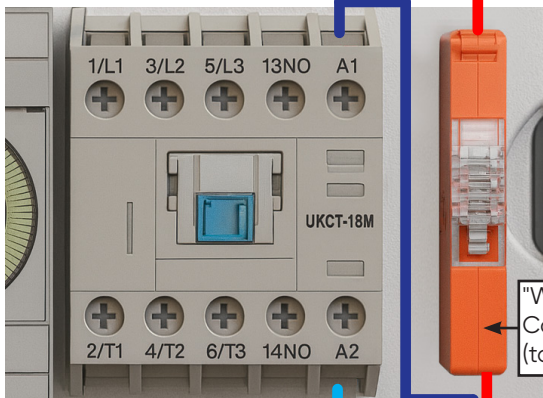

Motor contactor power supply



AUX 2

"WAGO" Connector (to be added)

INSTALLATION



Any person carrying out work on the electrical parts must be qualified and wear PPE (personal protective equipment): gloves, goggles, mat, etc...



Warning: use of the pool cover control switches present in the housing (Wi-Key receiver) must only be carried out by a person who is absolutely certain that there is no risk and that no-one will enter the pool during the operation.

GENERAL INFORMATION / CALIBRATING THE LIMIT SWITCHES (MOTOR DL & PL)

The power-on is done via the illuminated switch on the side of the electrical cabinet. As soon as the power is turned on, the switch lights up. You can check the initialization of the electronic board on the INFO display for a few seconds.

The electrical cabinet is designed for a maximum of 10 minutes of continuous operation. Beyond that, allow 30 minutes between operations. In case of overheating of certain components, the board enters self-protection mode and stops powering the motor until it cools to a safe temperature.

The operating range of the electrical cabinet is between 0°C and 50°C maximum.

Three operating modes are available and should be well understood by the installer.

AUTOMATIC MODE: This is the normal usage mode of the board when all programming has been done correctly. Advanced functions can be enabled, and alarms are active.

FORCE MODE: This is the typical mode for maintenance operations. Once entered into force mode, all configurations (limit switches, measured current levels, etc.) are overwritten, and the operator uses the motor without limit switches. This mode should be used with great care. It can also be used in case of sensor failure.

PROGRAMMING MODE: This is the mode that allows the operator to record the fundamental parameters for using the board in AUTOMATIC MODE. You enter PROGRAMMING MODE when you need to configure limit switches and the end of the speed ramp. In this mode, advanced functions are not active, as well as some alarms.

NOTE: For activating advanced functions, once the corresponding switch is activated, you will always need to restart the board using the illuminated power switch. This operation requires re-reading the parameters and active functions.

INSTALLATION

AFTER COMPLETE WIRING



For the PL 7710 motors :

1. Activate the dip-switch "CONF 2"
2. If necessary, turn off the control box and turn it back on.

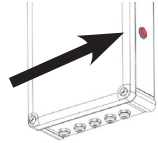

▶ CHECK THE DIRECTION OF THE COVER MOVEMENT INSIDE THE CONTROL BOX

To perform this check, use the FORCING mode by activating the dip-switch "FORCED." This operation is very important and should be extended to any potential control devices for the cover, such as remote controls, smartphone receivers, etc.



Verify that the cover opens the pool for swimming when pressing the OPEN button and closes when pressing the CLOSE button.

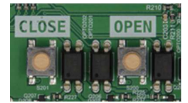

- If it's OK, deactivate the FORCING mode by deactivating the dip-switch "FORCED"



- If not, swap the two power wires at the motor terminal block and check the proper operation; then verify the wiring of the key switch on the terminal block.



! Only wire the key switch after checking the correct direction of movement by pressing the OPEN and CLOSE buttons.

▶ CHECK THE DIRECTION OF THE COVER MOVEMENT WITH THE CONTROLS

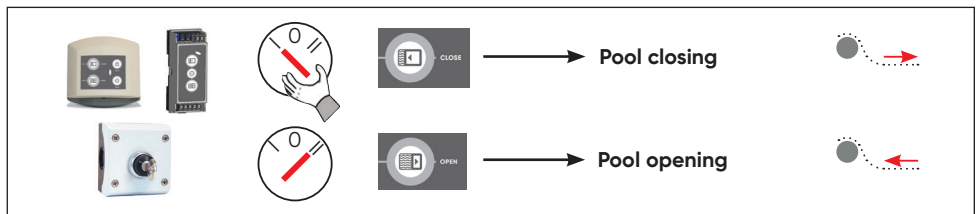

! If the control logic is not followed, check the Open / Close wiring of the control

INSTALLATION

PROGRAMMING MODE

▶ LIMIT SWITCH PROGRAMMING

The limit switch programming must be done with full visibility of the pool.



NEVER USE REMOTE CONTROLS OR RADIO DEVICES FOR SETTING THE LIMIT SWITCHES. The procedure must be carried out with the key switch or with the "OPEN" and "CLOSE" buttons on the board.

1. Check the direction of the cover movement (for more information, refer to the specific chapter above).
2. Press the "OPENED" button and hold it until the green LED next to it lights up. You have entered the "open" limit switch programming mode.
3. Set the cover to the rolled-up position (fully open).
4. Wait at least 5 seconds, then press the "OPENED" push button - The green LED turns off and the position is saved.
5. Press the "CLOSED" button until the green LED next to it lights up. You have entered the "closed" limit switch programming mode.
6. Set the cover to the unrolled position (fully closed). Ensure that no one is using the pool beforehand.
7. Wait at least 5 seconds, then press the "CLOSED" push button - The green LED turns off and the position is saved.

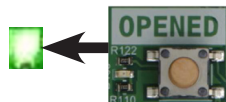

Now the limit switches are programmed, and the board operates in "AUTOMATIC" mode.

INSTALLATION

ADJUSTMENT OF THE AUTOMATIC SWITCH (CURRENT MONITORING)

This adjustment must be done after setting the end stops; refer to the installation manual of the cover mechanism.

The current monitoring allows triggering a current threshold alarm and stopping the motor if an anomaly or blockage occurs during pool opening or closing. To ensure the function activates properly, it is necessary to perform a learning procedure for current values; this acquisition must be done in both operating directions of the motor, as for submerged motors, the load differs significantly between opening and closing.

Note: Current monitoring must be activated last. If other functions are modified afterward, current monitoring must always be reprogrammed.

You must therefore carry out the following procedure:

1. Fully open the pool.
2. Set switches 1 and 2 to "ON" to temporarily activate pulse mode.
3. Select the correct current threshold for triggering the alarm using switches 7 and 8 (see figure at the end of this procedure).
4. Switch off the control panel, wait 3 seconds, then restart the panel using the main switch.
5. Check that the message "A" appears on the "INFO" display; this indicates that the function has been activated but an initial acquisition is required to complete the configuration.
6. Make sure no one and nothing is in the water; fully close the pool using the control without interrupting or disturbing the motor's movement. An upside-down "A" will appear on the "INFO" display, indicating that acquisition is required in the opposite direction.
7. Fully reopen the pool using the control without interrupting or disturbing the motor's movement.

INSTALLATION

8. If the acquisition completes without issues, the "INFO" display will show notification "b", meaning the function is now active; if the data are incomplete or the procedure is interrupted, the display will show notification "C".
9. If alarm "C" is active, the operator must set switches 7 and 8 to OFF and restart the control board to cancel the programming. The procedure can then be repeated from the beginning for a second attempt.
10. **Do not forget to return switches 1 and 2 to their original configuration once the amperometric (current) monitoring has been activated. Then switch the control panel off and back on after at least 10 seconds.**

Setting the threshold values via DIP switches 7 and 8 (60% recommended setting).

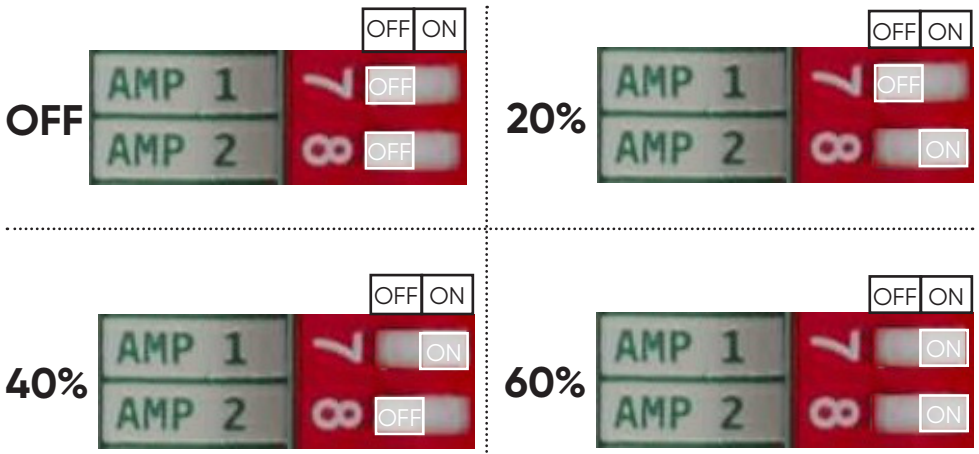

INSTALLATION

AUTOMATIC MODE

This mode allows the opening and closing of the cover during normal use, with automatic stop at the end of travel.

The cover is controlled in opening or closing by various control devices (Wall remote control, key switch, Wi-Key, etc.). The cover is automatically stopped at the pool ends by the previously programmed distance (see programming mode).

When the cover is at one end of the pool, you will not have a choice of movement direction; one direction temporarily becomes invalid: the closing direction will not work when the cover is in the fully closed position, and vice versa, the opening direction will not work when the cover is in the fully open position (see manual mode to override the programmed distance if needed).

All alarms are activated as well as any advanced functions selected by the user.



The use of the automatic switch in enabled mode is mandatory.

INSTALLATION

➤ CÂBLAGE DU RÉCEPTEUR WIKEY AVEC LE COFFRET DE PILOTAGE ET UN COFFRET ÉLECTRIQUE AQUA1.

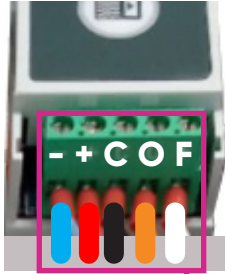

Electrical panel

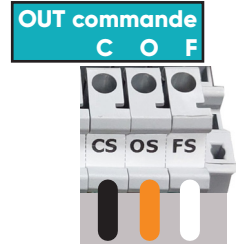
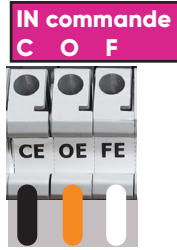

Control box

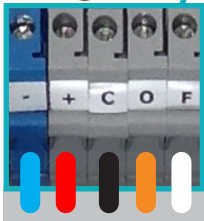
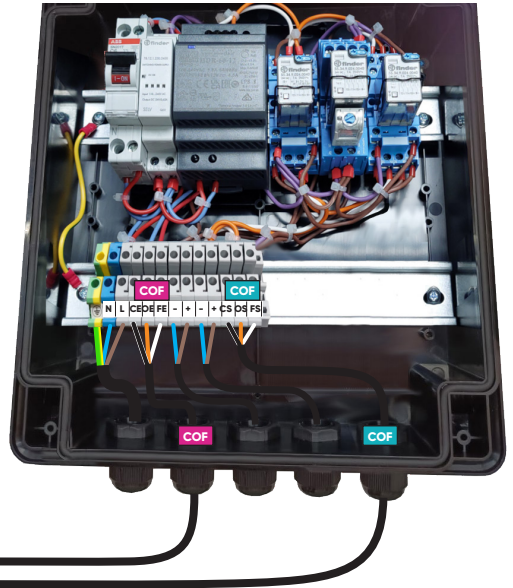
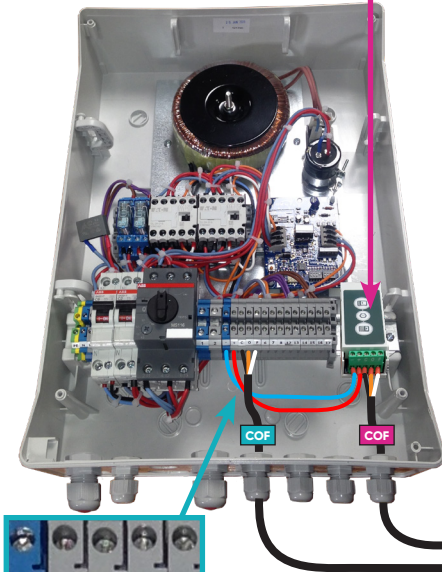

C : Common
O : Open
F : Close

3 x 0.75 mm² cables not included



The use of the automatic switch in enabled mode is mandatory.

INSTALLATION

WIRING THE KEY SWITCH CONTROL UNIT TO THE CONTROL BOX AND AN AQUAT ELECTRICAL PANEL



The use of the automatic switch in enabled mode is mandatory.

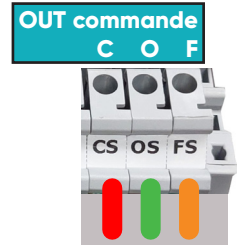
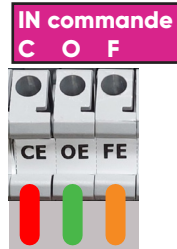

Electrical panel

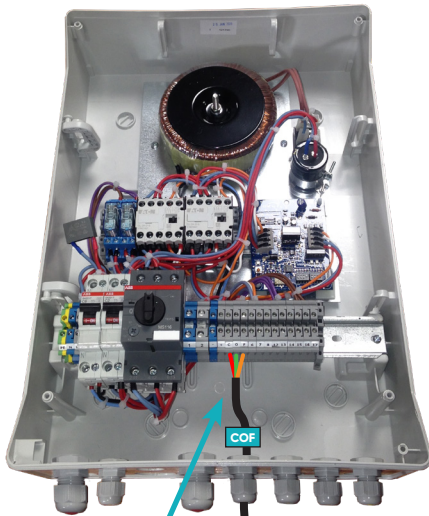

C : Common
O : Open
F : Close

Control box

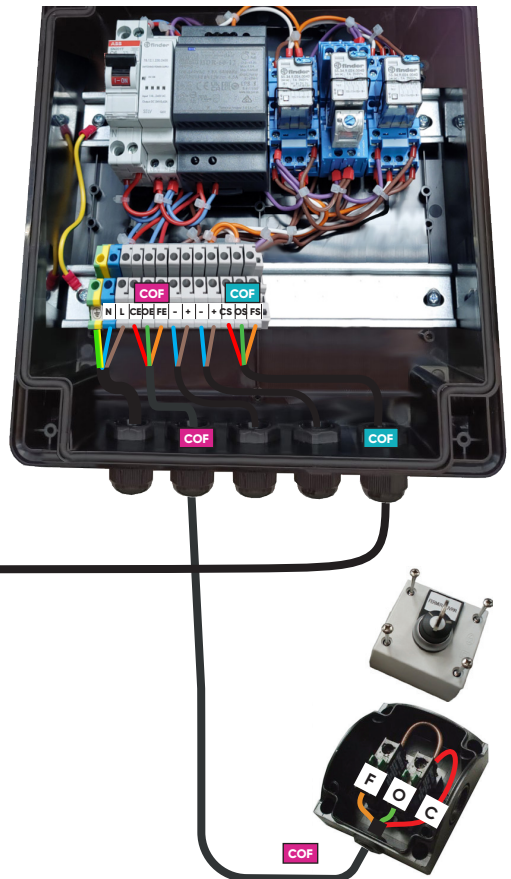

3 x 0.75 mm² cables not included

USE

HANDLING THE PUSHLOCK AUTOMATIC FRONT PANEL

To open the front panel, press on both sides.

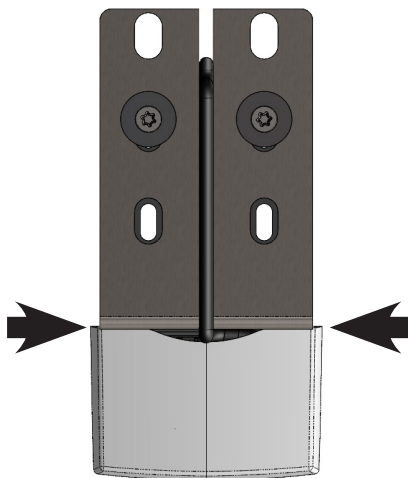
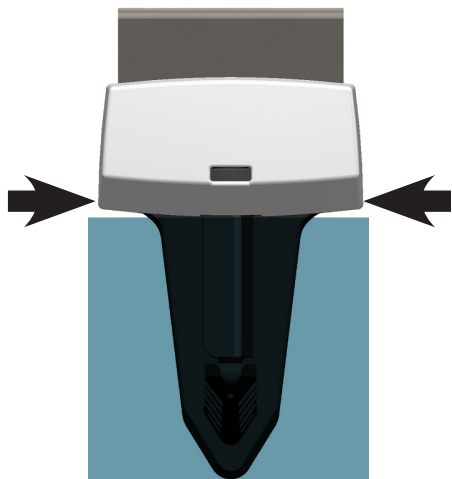

CLIC 

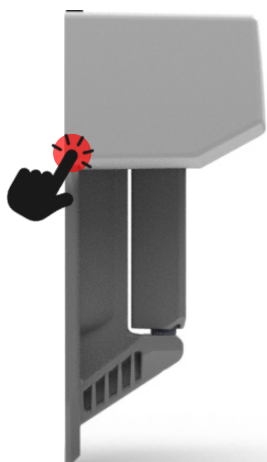

FIRST STARTUP AND INSPECTION

! Make sure the slats with the jaws are detached from the rest of the cover.



▶ POWERING UP THE CONTROL BOX

Before powering up the control box, manually set the Pushlock Automatics to the closed position. Then power up the control box.

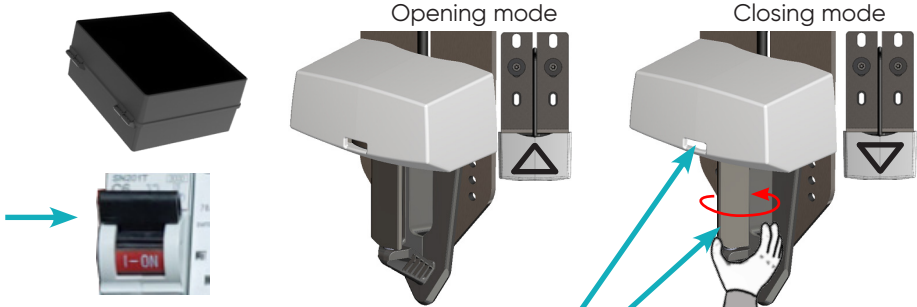

- A white rectangle indicate the closed position
- The tip of the rectangle points toward the pool

▶ OPENING

! For the first opening, detach the slat connection section from the rest of the cover.

Activate and hold the opening command for at least 7 seconds.
 → The Pushlock Automatics unlock, then the cover begins to roll up.

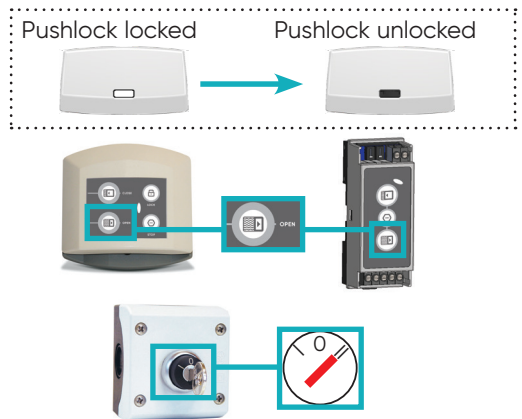
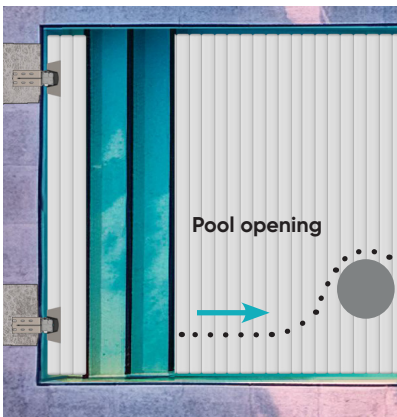

- If the PLA(s) lock instead of unlocking, reverse the power supply polarity of the affected PLA(s).
- If the cover closes instead, refer to the troubleshooting section for the relevant cover mechanism.

USE

CLOSING

Activate and hold the closing command. Keep the command activated without releasing it until the cover is fully closed.

→ The Pushlock Automatics lock and the cover unrolls.

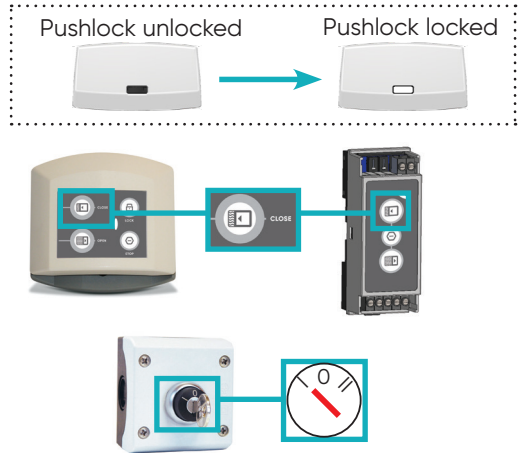
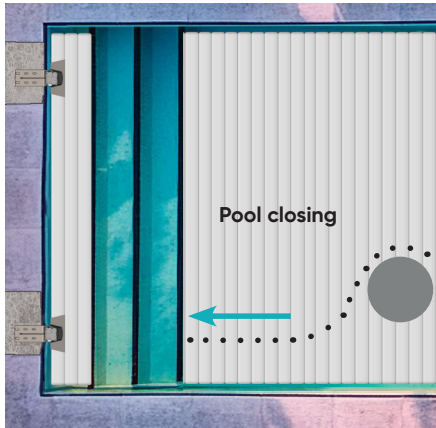

ASSEMBLING THE COVER TO THE LAST SLATS

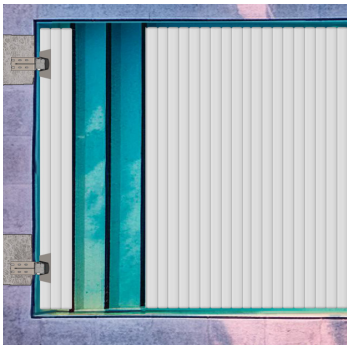

EMERGENCY LOCK (INCLUDED WITH THIS MANUAL IN THE CLEAR POUCH)

The emergency lock allows the system to be used in degraded mode, especially in the event of a power outage. It enables manual locking of the system in either the open or closed position. This tool is strictly for emergency or maintenance use and must not be used during normal operation of the cover. When installed on a Pushlock Automatic, the cover no longer complies with safety standards, and the user assumes full responsibility.



Opening mode

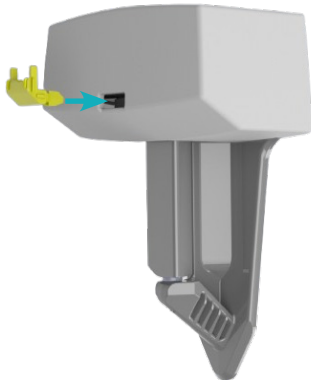

Closing mode

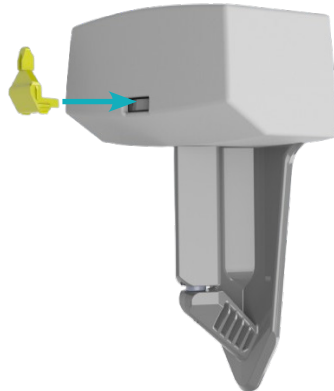

▶ CHECKING JAW ATTACHMENT ON THE PUSHLOCK AUTOMATIC

Before winterizing the cover or in case of prolonged non-use for several months, it is essential to check the proper attachment of the cover jaws to the Pushlock Automatics. This inspection ensures that the cover is securely fastened. A poorly attached cover may compromise safety in the event of someone accidentally falling onto it.

▶ INSPECTING THE CONDITION OF THE JAW CLAMPS

It is important to regularly check that the jaw clamps open and close properly. If not, the jaws must be cleaned. To do this, access them by unscrewing the two screws on the top of the jaw. Regular maintenance ensures the system operates correctly and the cover remains safe.

- ❗ **During disassembly, handle carefully, as the jaw contains an internal spring that may be under tension.**
During reassembly, tighten the screws manually. Overtightening may damage the system and affect its proper function.

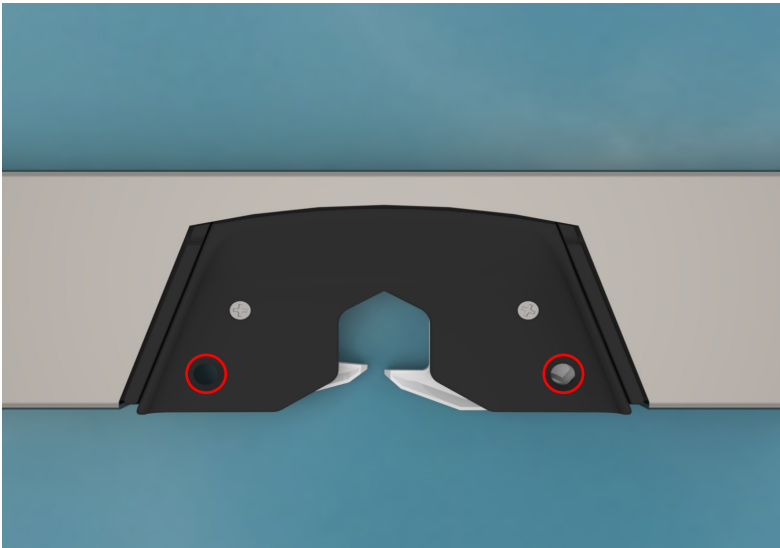

Ensure that the jaw clamps are fully locked. A properly locked clamp can be identified by the absence of visibility through the hole (as shown on the right). If the hole is visible (as shown on the left), it indicates the clamp is not properly positioned. Check and adjust if necessary to ensure optimal locking.

SERVICING/MAINTENANCE



During any intervention, the technician must wear PPE (personal protective equipment): gloves, goggles, mat, etc...

WATER LEVEL IN POOL

- Complying with the recommended minimum and maximum water levels ensures proper operation and compliance with the requirements of standard NF P90-308.
- It is advisable to pay close attention to fluctuations in the water level. The most suitable method (to ensure both monitoring and the necessary corrections) is to combine an overflow system with automatic filling.
- The target water level is specific to each pool and depends on the overall configuration of the cover. It is necessary to combine the recommendations relating to the reel and its possible decking with those relating to safety locks and slats.
- The NF P90-308 standard requirements imply compliance with the recommendations throughout the year and therefore an active winterisation without lowering the water level is needed.
- Pushlock automatic: ideal water level at mid-height of the hooking area, maximum variation ± 2.5 cm.



- Anchored, to be embedded: 7 cm and more
- Bracket: 7 to 14 cm

SERVICING/MAINTENANCE

INFO DISPLAY (UNIBOX CONTROL BOX)

The INFO display shows any alarms that allow the operator to detect and correct anomalies.

If two alarms are present at the same time, the display will show them in rotation, one after the other.

The acknowledgment of alarms is done using the motor control device (key switch or remote control); by pressing the device twice in the same direction, the alarm will be acknowledged, and the motor can then be restarted.

The list of alarms is as follows:

0	FIXED	Board startup error
1	FIXED	Limit switch programming error
2	FIXED	The motor is not wired
3	FIXED	Faulty sensor
4	FIXED	Blown fuse
7	FIXED	Anti-tear alarm activated; check the straps
8	FIXED	Motor overload
d	FIXED	Major fault on the motor drive

SERVICING/MAINTENANCE

INTERVENTION AND TROUBLESHOOTING (UNIBOX CONTROL BOX)

- ❗ **To be carried out only by qualified personnel.**
- ❗ **Before any intervention on the control box and after cutting off the power supply upstream of the box, wait 15 seconds for the capacitors to dissipate their residual energy.**
- ❗ **In case of malfunction of the control box or interventions other than the programming mode, manual mode, or pairing, activate the electrical separation device upstream.**

➤ DIAGNOSTIC TABLE

DETECTED PROBLEM	ALARM CODE	TROUBLESHOOTING ACTION
When activating the main switch, the control box does not start.		Check the wiring to the power supply. If the wiring is correct and single-phase current is present, check the ceramic fuse on the power supply input. If the error persists, replace the entire control box.
When activating the main switch, the initialization sequence ends with an alarm.	0	Turn off the board and restart it. If that does not work, perform a restart with the forced mode activated, which will overwrite the data. If the error persists, replace the entire control box.
After the first startup, the board starts correctly, the motor wiring is correct, but the motor cannot be activated.	No Action	Put the board in forced mode to overwrite any previously saved settings; reprogram the limit switches. Without programming, the motor can only move if forced mode is active or if the limit switch "open" programming has begun.
During the limit switch programming, alarm 1 is activated.	1	This alarm informs the user that the end of travel position has been exceeded. If there is no real reason for this issue, activate FORCED mode to overwrite the old values and then reprogram the limit switches. Acknowledge the alarm.

SERVICING/MAINTENANCE

DETECTED PROBLEM	ALARM CODE	TROUBLESHOOTING ACTION
During the course end programming or normal use, alarm 2 is triggered.	2	The motor power Cables (red and gray) are not properly connected to the control box, or there is a wiring issue between the motor and the control box. Carefully check the wiring to resolve the issue. You can switch to forcing mode to check if the motor is correctly connected. If there's no solution, the motor might be broken or short-circuited. Try powering it with batteries for a final confirmation or connect the motor directly to the control box without any intermediate wiring.
The display shows alarm 3 during motor operation, causing it to stop; the motor doesn't start, and alarm 3 is displayed.	3	This alarm is triggered if more than 3 seconds pass between two pulses from the sensor. First, check the sensor wiring. If there are no wiring issues, switch the board to FORCING mode and check if the motor runs at normal speed when operated manually. In this case, the internal sensor in the motor is broken and must be repaired by UNICUM. Until the replacement intervention, the cover can be used cautiously in forcing mode.
The motor doesn't start, and alarm 4 is displayed.	4	One of the fuses has blown; turn off the board completely and wait about 15 seconds. Disconnect it from the power supply. Disassemble and check the different fuses with a tester, and replace the faulty fuse. Restart the board and check the motor's proper functioning.

SERVICING/MAINTENANCE

DETECTED PROBLEM	ALARM CODE	TROUBLESHOOTING ACTION
The motor stops and alarm 7 is displayed.	7	The anti-tear function is active, and a current threshold breach was detected during the first few seconds of opening the cover. Check the straps and ensure no obstacles are preventing the motor from advancing. Acknowledge the alarm. If the alarm reactivates, set the option switch to OFF.
The motor stops and alarm 8 is displayed.	8	The motor is overloaded and has been stopped to prevent damage. This alarm is triggered when the time between two pulses from the sensor is greater than 3 seconds and a high current value is measured. Acknowledge the alarm and analyze the situation to find the cause that triggered the alarm.
Activating a function with the appropriate dip-switch does nothing.		To fully activate advanced optional functions such as the safety loop or impulse mode at opening, you must always reset the board by turning it off and then turning it back on.
The motor stops suddenly.	d	The drive controlling the motor has suffered an electrical shock and may be damaged. If the alarm persists after acknowledgment, the defective board must be replaced.

SERVICING/MAINTENANCE

FUSE REPLACEMENT



Replace the fuses with the control box completely powered off. Failure to follow this safety standard poses a high risk of electric shock. This operation must be carried out by trained and qualified personnel.

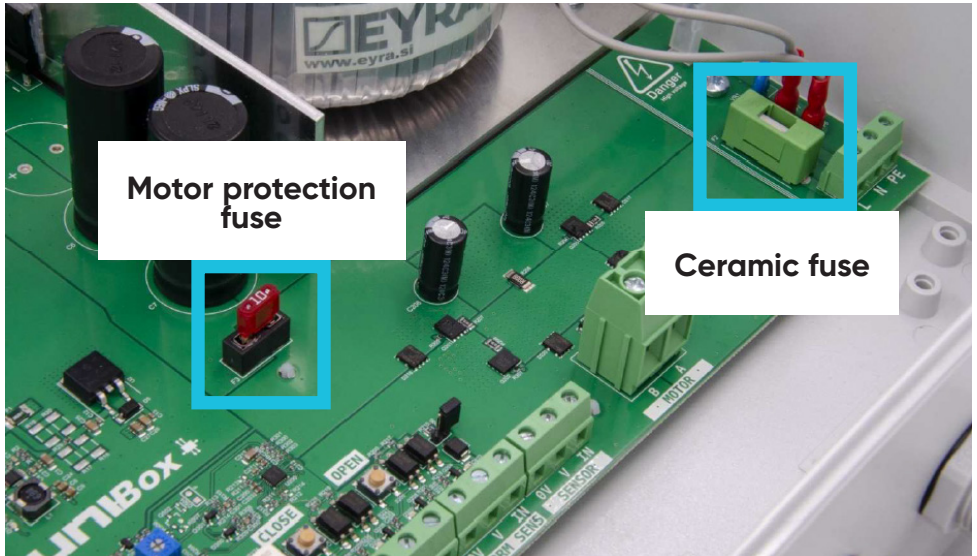

Motor Protection Fuse:

- 10A for Unibox 120VA and 250VA.
- 15A for Unibox 450VA.

COMPLETE RESET OF THE ELECTRONIC BOARD

To completely erase the memory of the electronic board, follow these steps :

1. Turn all the dip-switches for advanced functions to OFF.

2. Set the FORCED dip-switch to ON

3. Then, turn the dip-switch to OFF.

4. Restart the board.

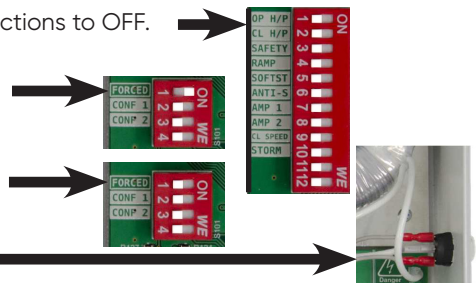

SERVICING/MAINTENANCE

▶ MOTOR CONTROL FROM THE CONTROL BOX DURING MAINTENANCE

! **The use of these buttons is strictly prohibited without visibility of the pool.**

During maintenance and troubleshooting, it is possible to control the movement of the motor directly from the control box; this usage method is not allowed if the pool is not directly visible and cannot be monitored during the movement of the cover.

The "OPEN" and "CLOSE" buttons allow you to open or close the cover at any time, even in the absence of a key-controlled controller.

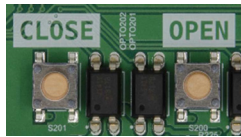

SERVICING/MAINTENANCE

SPARE PARTS

Online catalogue :



<https://www.my-cfgroup.fr/fr/pièces-detachees>

TROUBLESHOOTING GUIDE



In-ground pool cover :

<https://view.publitas.com/cfgroup/guide-depannage-volet-immerge-Unibox-fr/>



Wikey :

<https://view.publitas.com/cfgroup/quick-troubleshooting-guide-wikey/>

REGULATIONS

WARRANTY CONDITION

log on to www.del-piscine.fr to consult all our guarantees.



<https://www.del-piscine.fr/rechercher-une-garantie>

SAFETY ADVICE

Please read the recommendations set out below with care.

WARNING

Swimming pools can represent a serious danger for your children. Drowning can happen very quickly.

Children who are close to a swimming pool need to be watched constantly and actively, even if they know how to swim.

Learn lifesaving skills.

The physical presence of an adult is absolutely essential whenever the pool is open.



Memorise the telephone numbers for the emergency services and ensure that they are displayed close to the pool.

18 (in France) or **112**

FIRE SERVICE

15

**AMBULANCE
SERVICE**

(write the number that applies in your region)



POISON CONTROL

CENTRE

SAFETY ADVICE

- This section is by no means a replacement for common sense or individual responsibility. Its aim is not to replace the vigilance of parents and/or responsible adults, who remain the essential factor in ensuring the protection of young children.
- **Warning:** safety is only guaranteed when the cover is closed, locked and correctly installed in compliance with the manufacturer's instructions.
- The cover must systematically be closed if you are absent from home, even for a very short period.
- Check that no persons and no foreign objects are in the pool before and during opening and closing operations.
- Store the devices and/or tools needed to operate the covers out of the reach of children.
- Operation of the mechanism must only be carried out by a responsible adult.
- With the exception of movable floors, movable terraces and the covering elements provided for this purpose (e.g. gratings), do not climb, walk or jump on a safety cover.
- Take all necessary measures to prevent access to the pool for young children until the cover is repaired or when a malfunction is observed that prevents closing or in case of temporary unavailability of the equipment or the pool.
- Respect the water levels designated by the manufacturer.
- Children must not play with the appliance.
- This appliance may be used by children aged 8 and over, and by persons with reduced physical, sensory or mental capabilities or lack of experience and knowledge if they have received supervision or instructions concerning the safe use of the appliance and understand the hazards involved.

A child can drown in less than 3 minutes, no type of protection can ever replace the watchful eye and vigilance of a responsible adult.

RECYCLING

PACKAGING



Dispose of the packaging in line with current rules and regulations.

END OF LIFE



- Do not throw away your discarded equipment or used batteries with unsorted household waste.
- It is your responsibility to dispose of all your waste, particularly electrical and electronic equipment, by taking it to a dedicated collection point for recycling.
- Certain products potentially contain substances that are hazardous to the environment, and these will be removed or neutralised.
- Find out about existing take-back and collection systems.



discard the manual in line with the current regulations.



Adresses sur quefairedemesdechets.fr

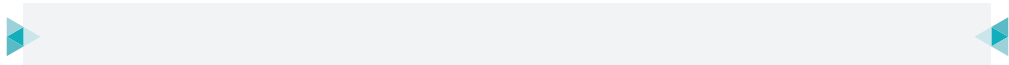

DEL SAS
ZA LA CROIX ROUGE
35530 BRÉCÉ - FRANCE

☎ +33 (0)9 70 72 5000 / INFO.FR@CF.GROUP

STAMP

A brand by CF group



ORIGINAL INSTRUCTIONS

A-DOTE04104.L1 / 04.2026