



QUICK GUIDE

Rollinsinde 1 side Tubular motor

Required equipment for installation on a traditional concrete structure:

Spirit level



Hammer



Concrete drill bit Ø 12/14/25



Measuring tape



Screwdriver  



Open-end wrench (size 10-13)



Rotary hammer

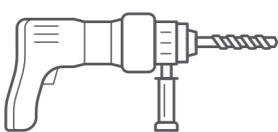

Cutter



Installation steps and approximate durations:

Step	Duration	Number of people
Pool preparation	2h	Minimum 1
Electrical installation	2h	Minimum 1
Installation	4h	2 recommended

(Indicative durations depending on the cover versions)

STEP

Pool preparation

Pit dimensions

1 Side version

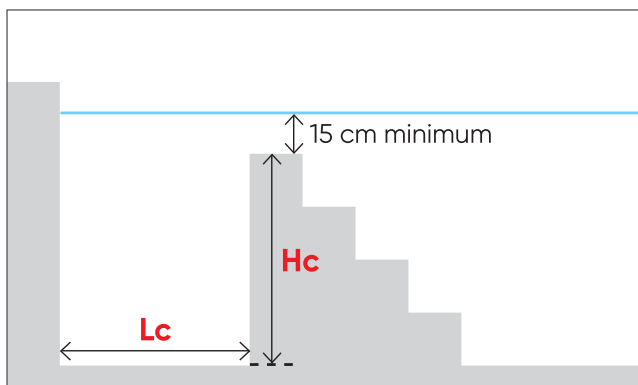

Lc: Pit width - Hc: Pit height

Intermediate support*

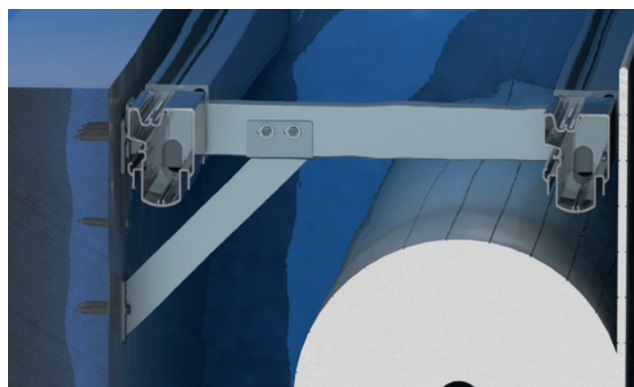

Pool length, including steps	Standard pit Lc = 82 cm		Optimized pit			
	Hc without support*	Hc with support*	Minimum Lc	Minimum Hc without support*	Minimum Hc with support*	
5 m	87 cm	87 cm	54 cm	72 cm		
6 m			55 cm	73 cm		
7 m			58 cm	74 cm		
8 m			60 cm	75 cm		
9 m			62 cm	76 cm		
10 m			64 cm	77 cm		
11 m			66 cm	78 cm	80 cm	
12 m			68 cm	79 cm	82 cm	
13 m			70 cm	80 cm	84 cm	
14 m			72 cm	81 cm	86 cm	
15 m			73 cm	82 cm	87 cm	
16 m			88 cm	75 cm	83 cm	88 cm
17 m			89 cm	76 cm	84 cm	89 cm
18 m			92 cm	79 cm	85 cm	92 cm
19 m			94 cm	81 cm	86 cm	94 cm
20 m	95 cm	82 cm	87 cm	95 cm		

*Intermediate support is mandatory for pools wider than 6 m, and 4.50 m when finished with ceramic stoneware or with a decking exceeding 50 kg/m².

An optimized pit width (Lc) results in a longer manufacturing lead time for the intermediate support.

STEP

Pool preparation

Positioning of the wall fixings for the reel system

Install the insert mount versions of the wall fixings during concrete pouring or when resuming concreting, in accordance with the site organization.

Wall fixings using anchors do not require concrete reinforcement and can be installed at the start of the cover installation.

Ensure access to the rear of the pool to allow installation of the motor cable (see the step "installation").

1 Side version

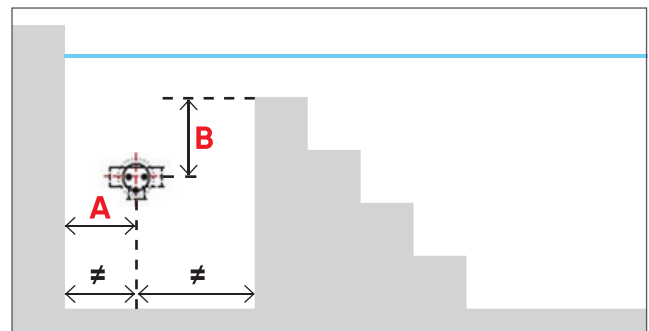

Pool length, including stairs	A	B without support*	B with support*
5 m	25 cm	43,5 cm	43,5 cm
6 m	26 cm		
7 m	27 cm		
8 m	28 cm		
9 m	29 cm		
10 m	30 cm		45 cm
11 m	31 cm		46 cm
12 m	32 cm		47 cm
13 m	33 cm		48 cm
14 m	34 cm		49 cm
15 m	35 cm		50 cm
16 m	36 cm		51 cm
17 m	37 cm		52 cm
18 m	38 cm	53 cm	
19 m	39 cm	54 cm	
20 m	40 cm		

*Refer to page 2.

STEP

Pool preparation

Positioning of the wall units for the beams

Install the **insert-mount** versions of the wall fixings during concrete pouring or during subsequent pours, in accordance with the site organization.

The **surface mount** wall fixings require no concrete work and can be installed at the start of the cover installation (installation template provided).

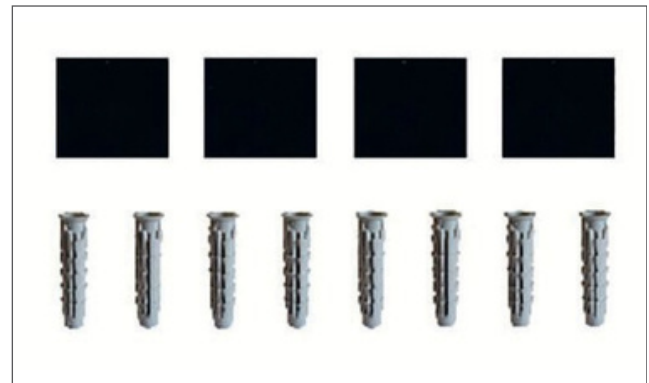
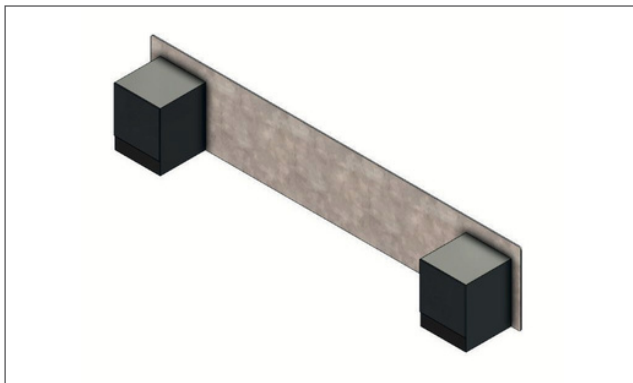
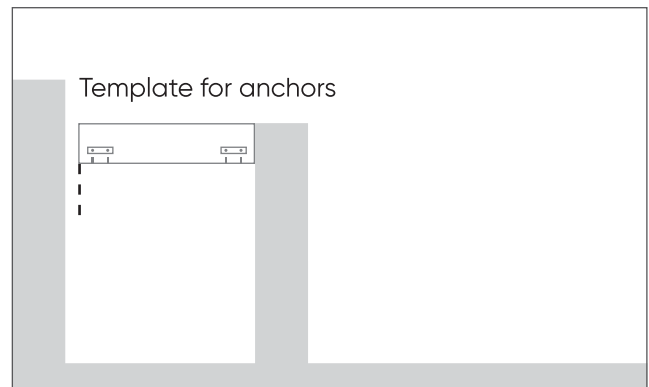
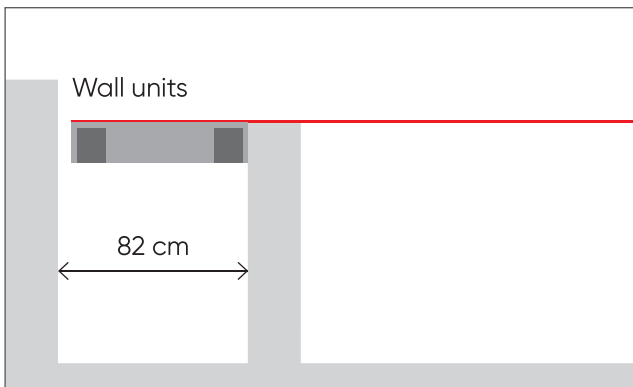

The insert mount fixings are exclusively designed for standard 82 cm pits .
The surface mount fixings with anchors can be adjusted to any pit width.

Keep the seals provided with the wall fixings to position them prior to installing the watertightness.

STEP

Electrical preparation

Between the pool and the technical room

Install a cable protection conduit with an internal diameter of 40mm between the technical room and the corner of the pool where the motor cover will be positioned.

Install a junction box at the pool edge at the end of the conduit, unless the motor cable is supplied with an extended length reaching directly to the box.

Type of cable recommended:

From 1 to 25 meters	2 x 6 mm ² (motor power supply) + 3 x 1.5 mm ² (limit switch)
From 26 to 50 meters	2 x 10 mm ² (motor power supply) + 3 x 1.5 mm ² (limit switch)

In the technical room

Plan the cable routing for:

- The motor power and limit switch cables leading to the control box.
- Connections to any additional equipment.

Type of cable recommended :

Key switch (not needed with Wi-key control)	Remote Wi-key control option * Control panel / Exterior of the technical room	StopFlow function Control panel / Filtration control box	StopFlow function Control panel/ Chlorinator (without ORP sensor)
3 x 1.5 mm ²	5 x 1.5 mm ²	2 x 1.5 mm ²	2 x 1.5 mm ²

**Necessary if the distance between the control box and the emitter is greater than 50 meters in an open field, or if the box is located in a metal-clad room.*

STEP

Installation

Sealing gaskets have been fitted to the wall fixings, and the pool waterproofing has been completed.

Assemble the components at the rear of the wall units for the motor to rout the motor cable to the junction box, and prepare the cable pathways either through the wall or under the coping.

- Insert-mount fixings **1**: connect the supplied Ø32 flexible hose to the rear of the part to ensure sealing.
- Surface-mount fixings with wall crossing **2**: connect the supplied Ø32 flexible hose to the rear of the stainless steel wall unit using the provided connector.
- Surface-mount fixings with cable protection under coping **3** or with non-wall crossing outlet **4**: install a rigid riser at the rear.

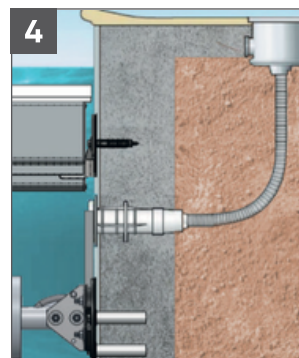
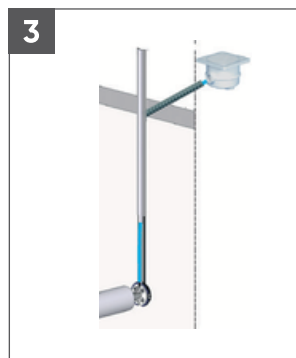

Start filling the cover pit with water to apply tension to the coating (minimum 15 cm of water).

Adhere the gaskets to the coating and install the mechanical flanges.

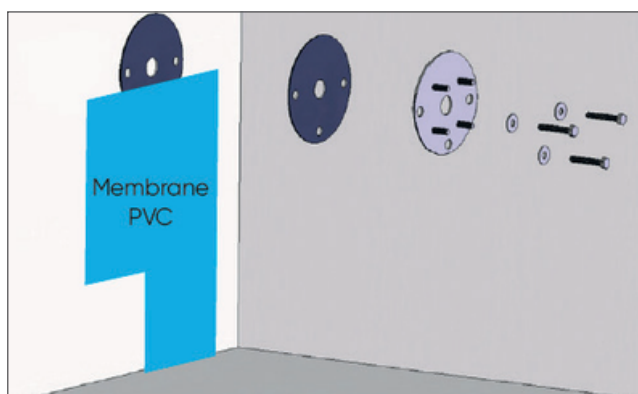

STEP

Installation

Sealing gaskets have been fitted to the wall fixings, and the pool waterproofing has been completed.

Install the roller and connect the motor cable.

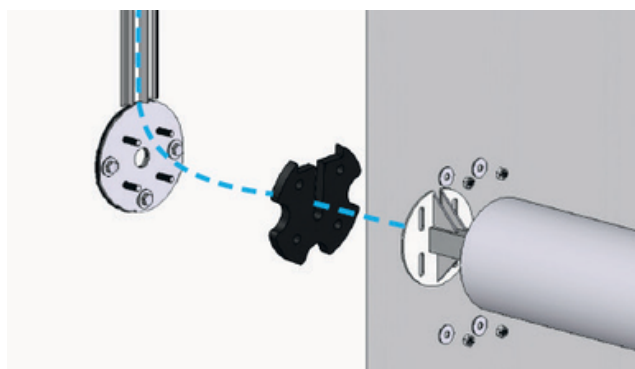
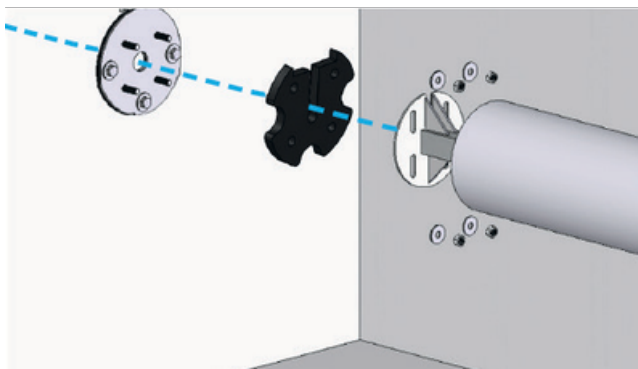

Install the beam supports.

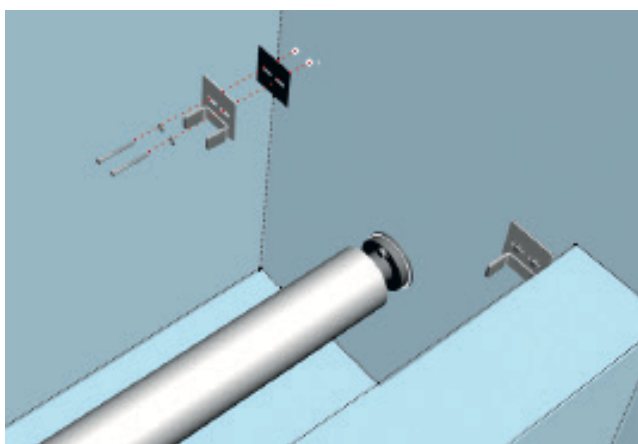

Install the beams onto the supports.

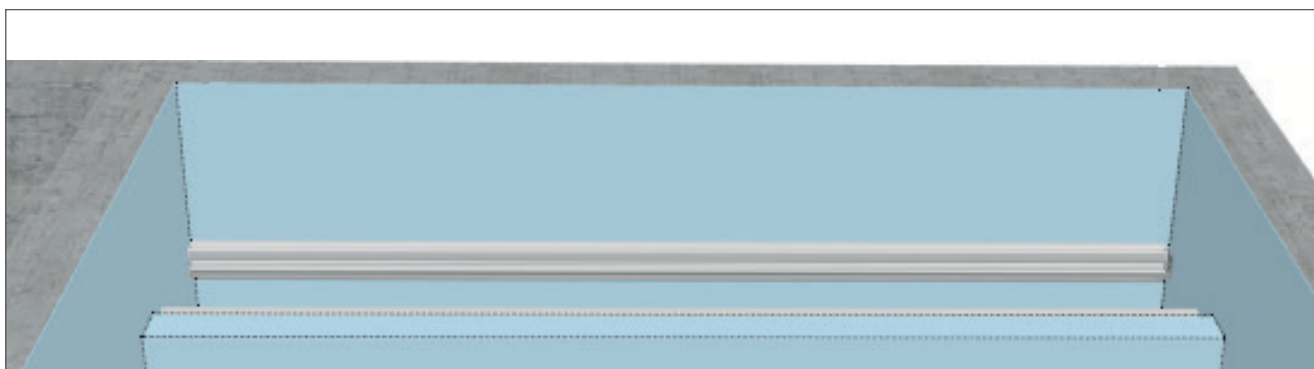

STEP

Installation

Sealing gaskets have been fitted to the wall fixings, and the pool waterproofing has been completed.

Position the counterweights, following the trajectory of the straps.

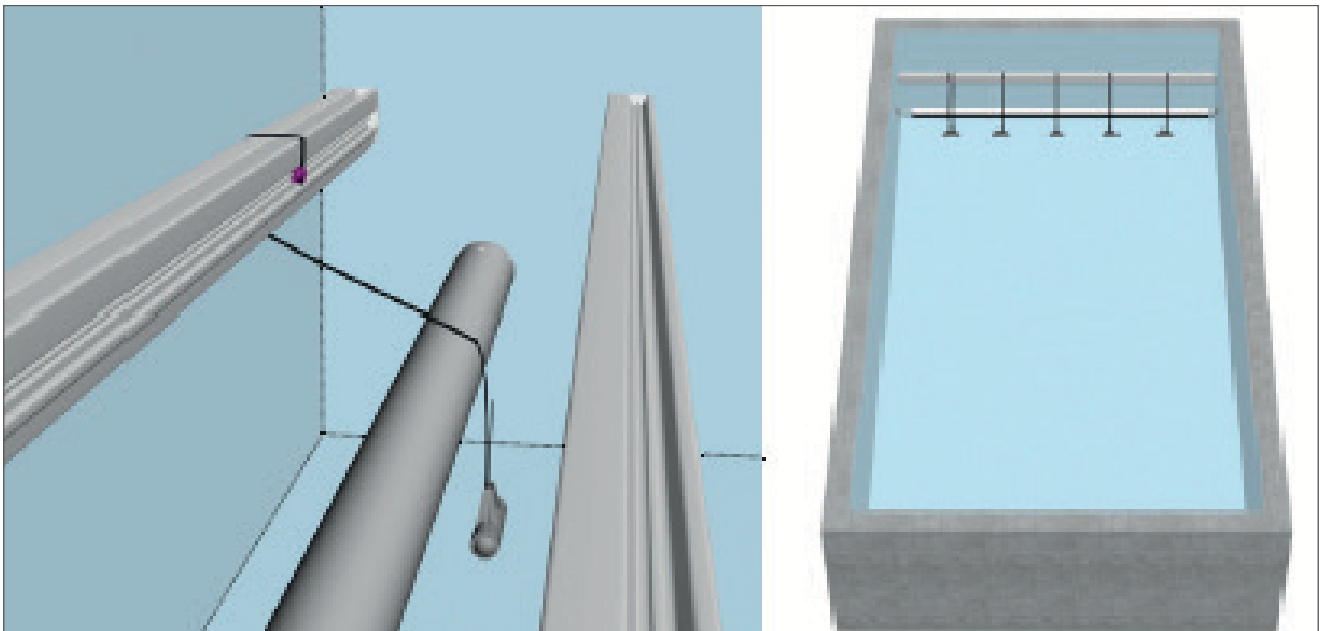

Install the control box, connect the power supply, the motor power supply, the limit switches, and the control system.

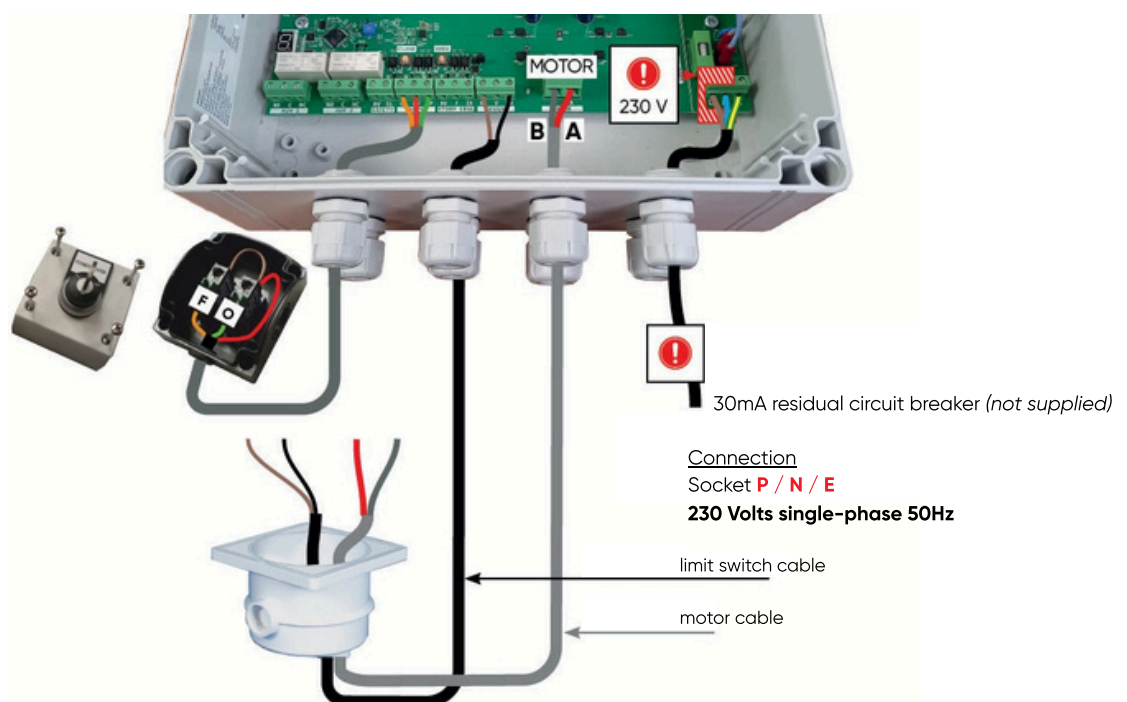

STEP

Installation

Sealing gaskets have been fitted to the wall fixings, and the pool waterproofing has been completed.

Connect the motor to the junction box and verify the direction of rotation using the control box. Seal the junction box following the installation of the cover.

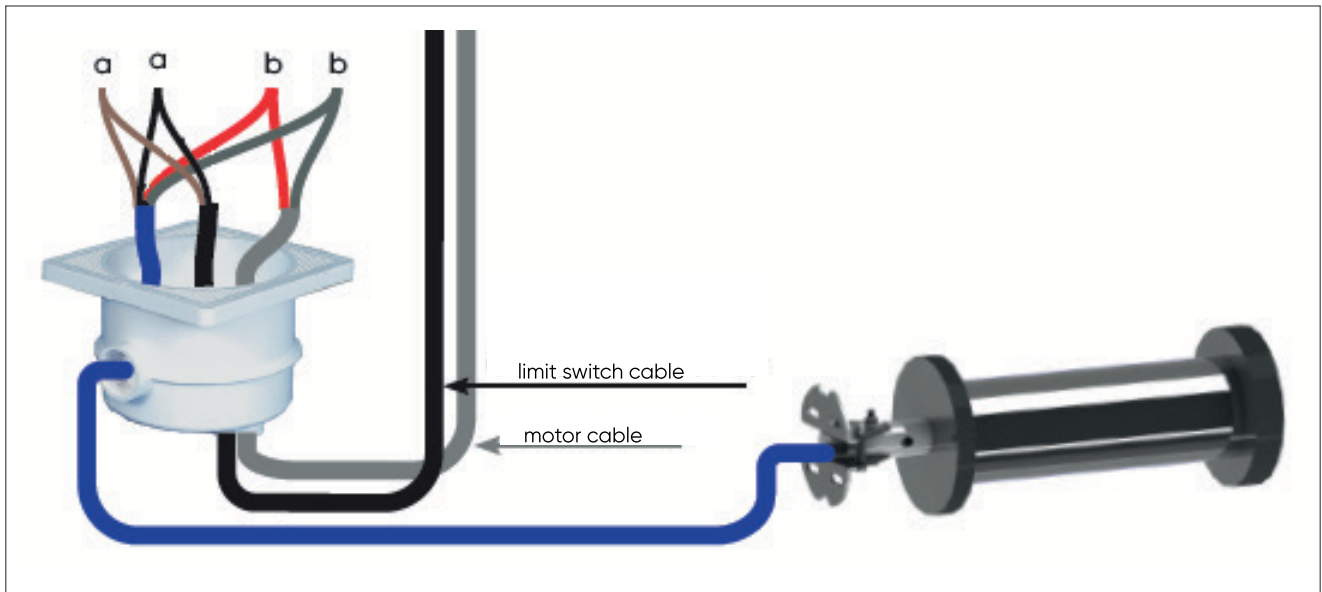

Assemble the slats along with the provided accessories, and attach the straps.

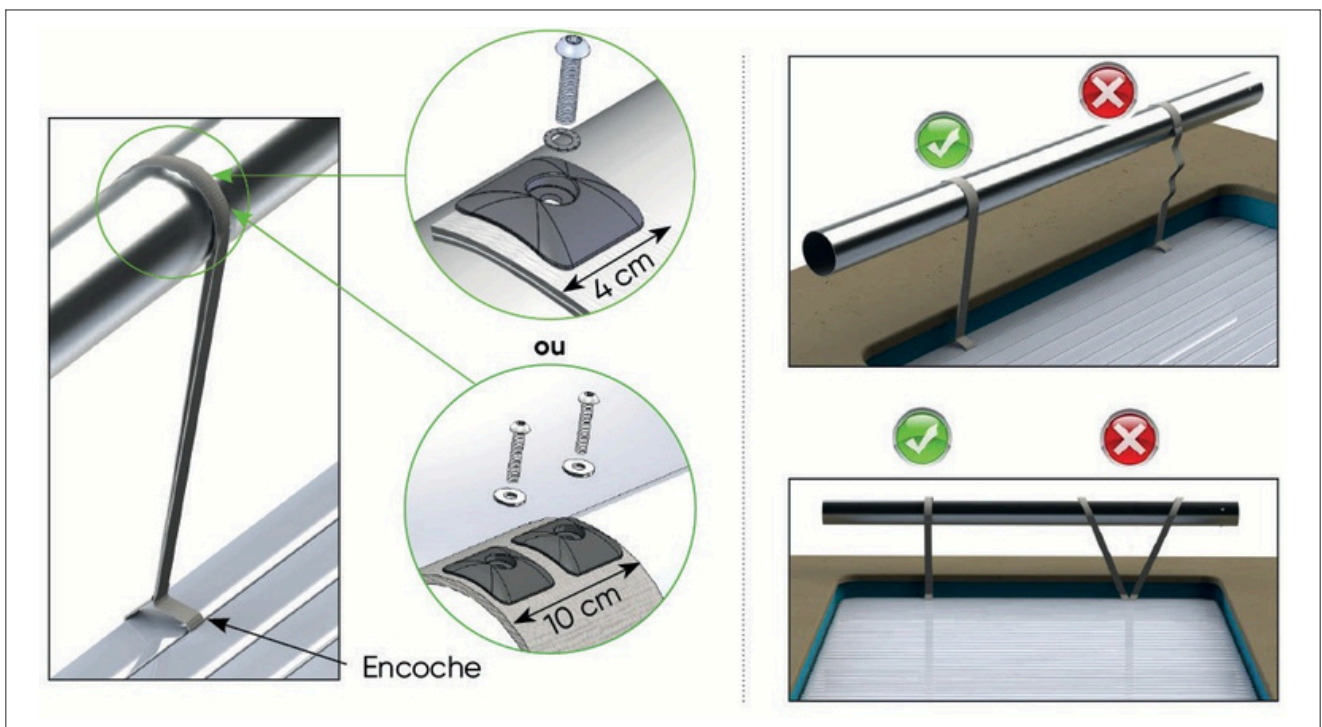

STEP

Installation

Sealing gaskets have been fitted to the wall fixings, and the pool waterproofing has been completed.

Install the safety kits by aligning them with the pre-installed straps on the slats according to the provided diagram.

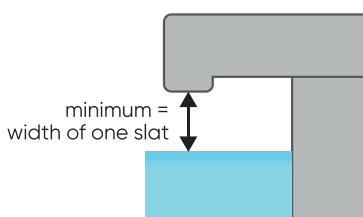
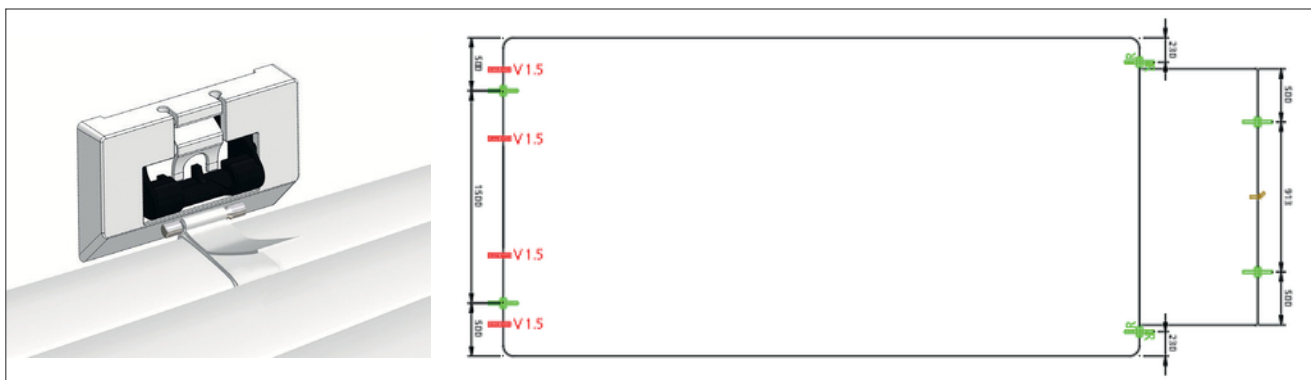

CAUTION:
Observe the water level.

Adjust the limit switches.

Install the decking

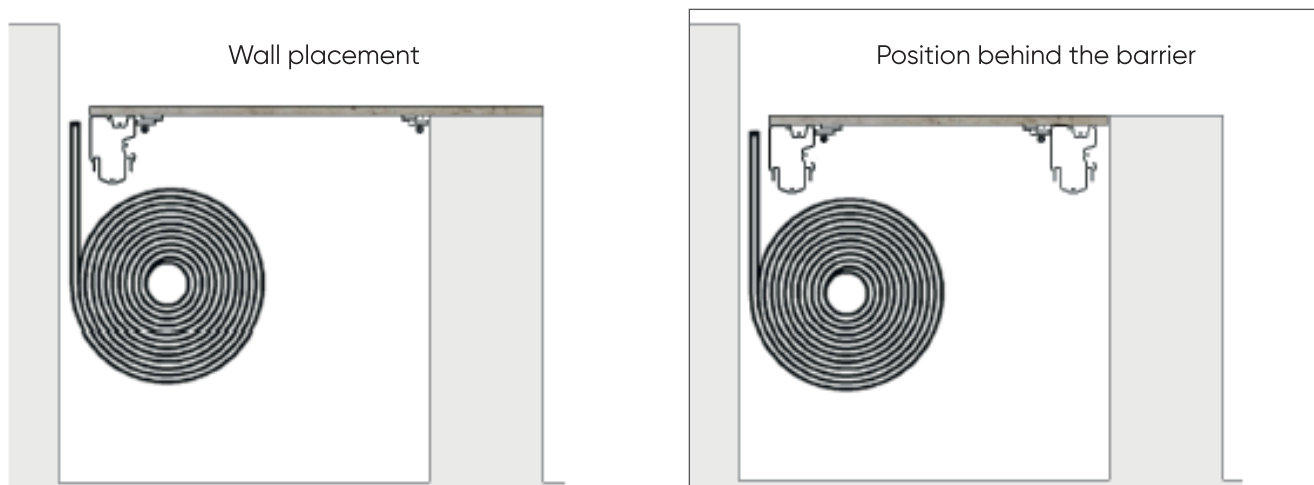

Finalize the installation of any additional option.

Consult the installation instructions for further details.



QUICK GUIDE

Rollinsinde 1 side Tubular motor

Additional information
on my-cfgroup.fr



+33 (0)9 70 72 5000
info.fr@cf.group

a CF group brand