



NOTICE D'INSTALLATION

INSTALLATION / ENTRETIEN / MAINTENANCE / CONSEILS DE SÉCURITÉ



DEL 

PROCÉDURE DE REMPLACEMENT DU MOTEUR MIT

INFORMATION

Suite à l'amélioration du moteur par le fabricant, la position des perçages de fixation sur le mât a été modifiée. Avant d'installer votre nouveau moteur, il est impératif de vérifier si votre ancien moteur appartient déjà à cette nouvelle génération.

▶ COMMENT LES DIFFÉRENCIER ?

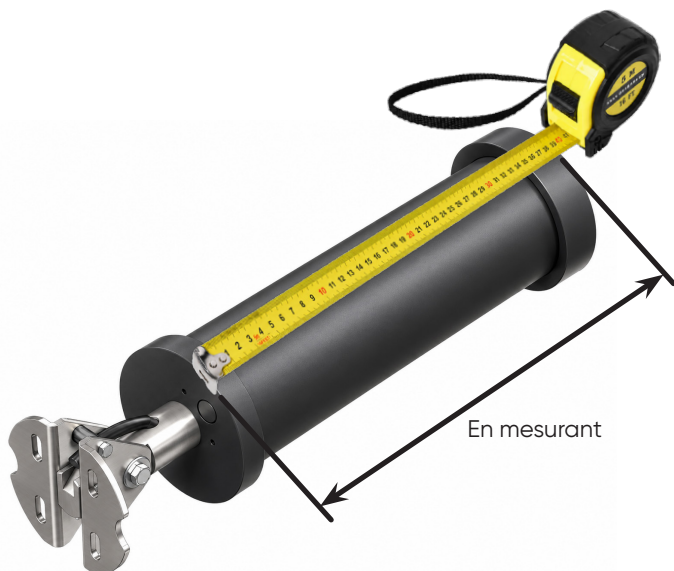







| Moteur | Ancienne génération | Nouvelle génération |
|--------|---------------------|---------------------|
| PL6010 | 388 mm | 450 mm |
| PL7710 | 425 mm | 450 mm |
| PL3210 | 356 mm | Aucun changement |
| PL1210 | 356 mm | Aucun changement |

! Si votre ancien moteur était déjà un modèle de nouvelle génération, vous pouvez installer directement le nouveau moteur. Dans le cas contraire, veuillez lire la suite de cette notice.

DESRIPTIF

OUTILS NÉCESSAIRES AU MONTAGE



| | | | |
|---|-------------|---|---------|
|  | Perceuse |  | Maillet |
|  Ø5 | Foret métal |  | Mètre |
|  Ø6 | Taraud |  | Poinçon |
|  T4 | Clé allen | | |

INSTALLATION

! Votre moteur est d'ancienne génération. Veuillez suivre les instructions suivantes.

MODIFICATION DU MÂT

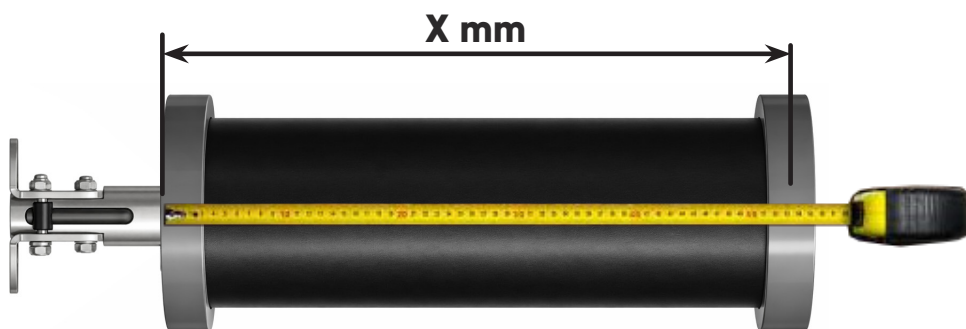

➤ ÉTAPE - 1

À l'aide d'un marqueur, repérez les nouveaux perçages à faire à **X** mm du bord du tube et sur tout le tour.

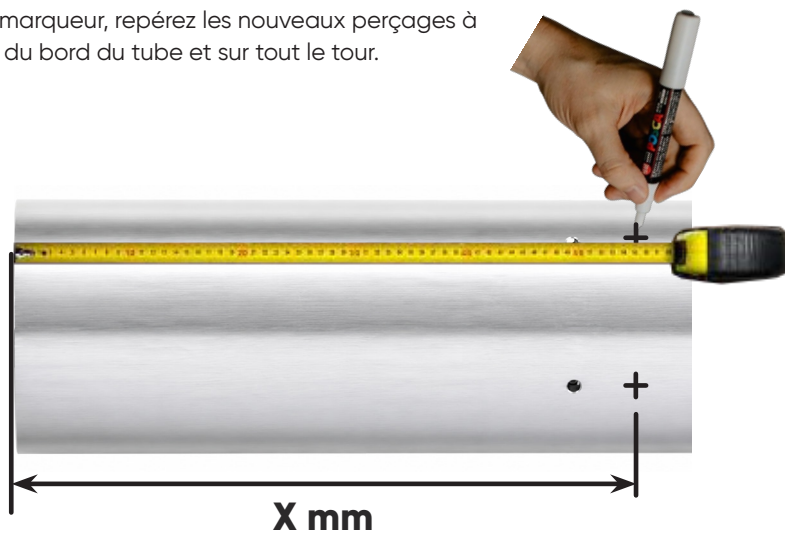

INSTALLATION

ÉTAPE - 2



Pointer au niveau de la marque.

ÉTAPE - 3

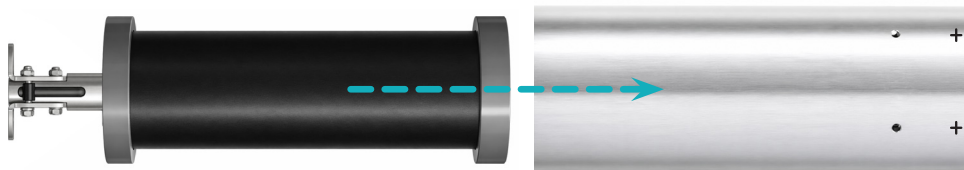

Insérer le moteur dans le tube.



Le bord du moteur doit coïncider avec le bord du tube.

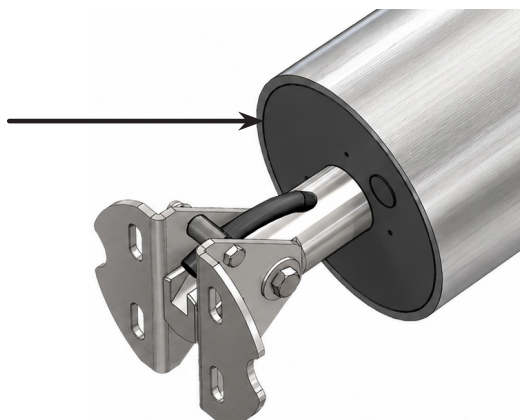

INSTALLATION

ÉTAPE - 4

Percez le tube et le moteur à l'aide du foret $\varnothing 5$ mm à l'endroit des marquages. Puis tarauder uniquement le tube avec un taraud $\varnothing 6$.



32 ±1 mm de profondeur de perçage

35 mm de profondeur de perçage **maximum**

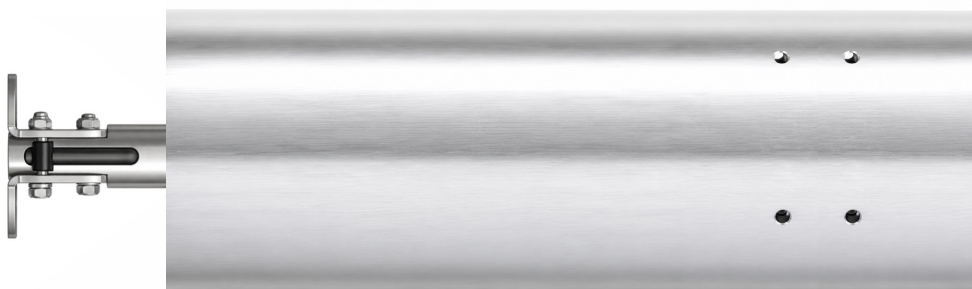

⚠ Après le perçage, veillez à ne surtout pas déplacer le mât ni le moteur.

INSTALLATION

ÉTAPE - 5

Fixez le moteur au tube à l'aide des vis et des rondelles.



EN



INSTALLATION GUIDELINES

INSTALLATION/SERVICING/MAINTENANCE/SAFETY ADVICE



DEL 

MIT MOTOR REPLACEMENT PROCEDURE

INFORMATION

Following the manufacturer's motor improvement, the position of the mounting holes on the mast has been changed. Before installing your new motor, it is essential to check whether your old motor already belongs to this new generation.

▶ HOW CAN THEY BE DISTINGUISHED ?

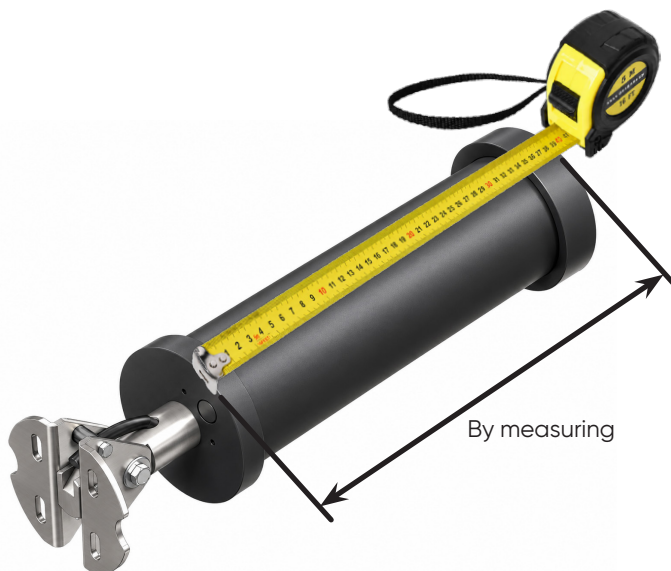







| Motor | Old generation | New generation |
|--------|----------------|----------------|
| PL6010 | 388 mm | 450 mm |
| PL7710 | 425 mm | 450 mm |
| PL3210 | 356 mm | No change |
| PL1210 | 356 mm | No change |

! If your old motor was already a new-generation model, you can install the new motor directly. Otherwise, please read the rest of this manual.

DESCRIPTION

COMPONENTS PROVIDED



| | | |
|---|--|---|
|  Drill | |  Mallet |
|  Ø5 Metal drill bit | |  Meter |
|  Ø6 Tap | |  Center punch |
|  T4 Hex key | | |

INSTALLATION

Your motor is an older-generation model. Please follow the instructions below.

MAST MODIFICATION

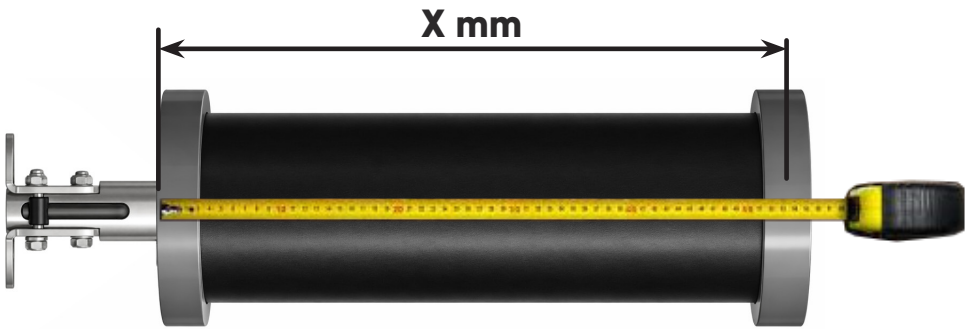

STEP - 1

Using a marker, mark the positions of the new holes to be made at 435 mm from the edge of the tube, all around it.

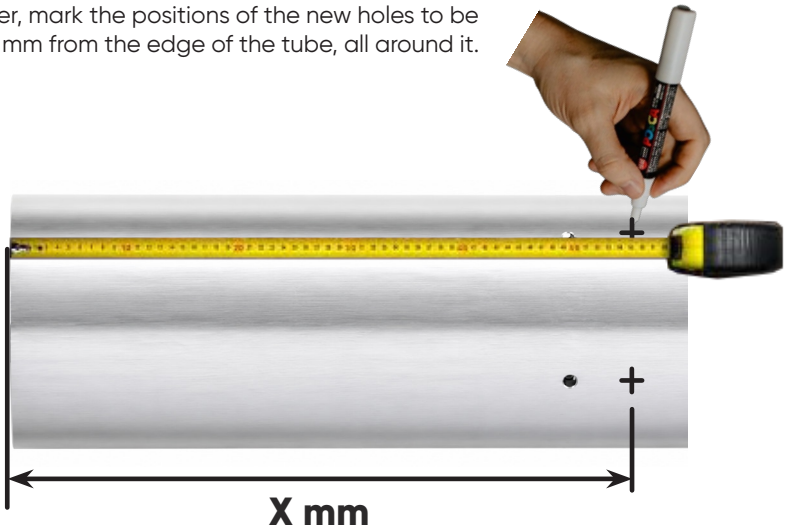

INSTALLATION

STEP - 2



Punch at the mark.

STEP - 3

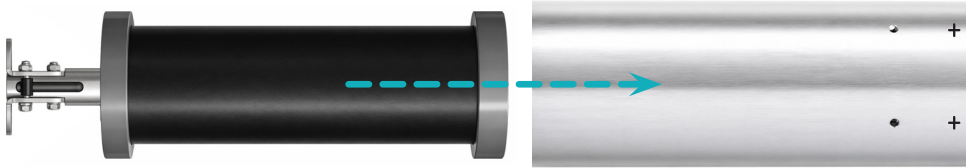

Insert the motor into the tube.



The edge of the motor must align with the edge of the tube.

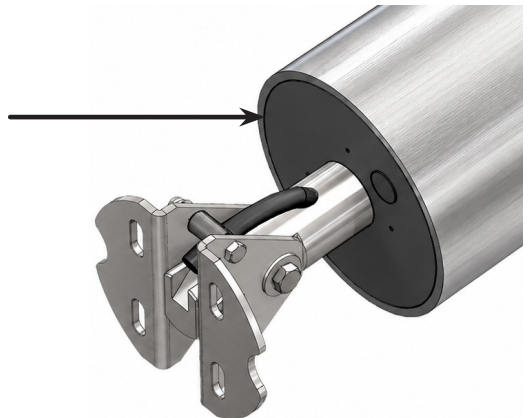

INSTALLATION

STEP - 4

Drill the tube and the motor at the marked positions using a $\varnothing 5$ mm drill bit. Then tap only the tube with an $\varnothing 6$ tap.

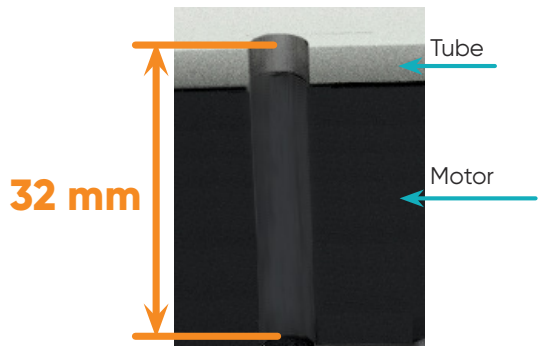

32 ±1 mm drilling depth

35 mm drilling depth **maximum**



! After drilling, make sure not to move the mast or the motor under any circumstances.

INSTALLATION

STEP - 5

Secure the motor to the tube using the screws and washers.



DE



INSTALLATIONSANLEITUNG

INSTALLATION / WARTUNG / INSTANDHALTUNG / SICHERHEITSHINWEISE



DEL 

AUSTAUSCHVERFAHREN DES MIT-MOTORS

INFORMATION

Aufgrund der vom Hersteller vorgenommenen Verbesserung des Motors wurde die Position der Befestigungsbohrungen am Mast geändert. Vor dem Einbau Ihres neuen Motors müssen Sie unbedingt prüfen, ob Ihr alter Motor bereits zu dieser neuen

▶ WIE KANN MAN SIE UNTERSCHIEDEN?

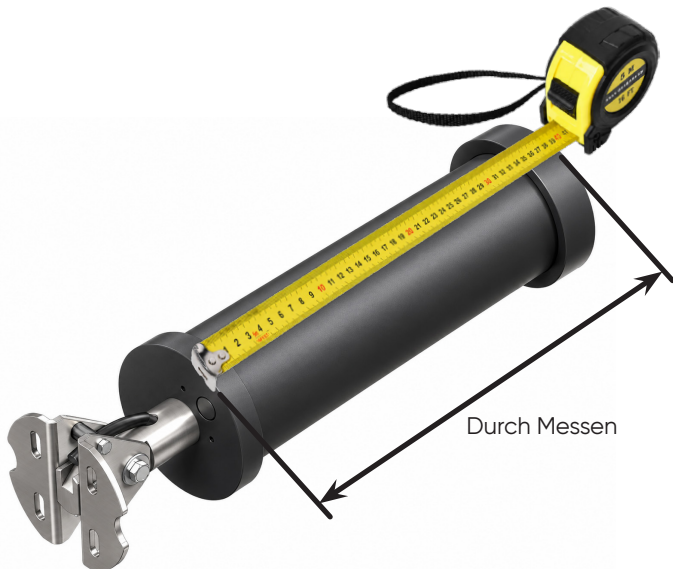







| Motor | Alte Generation | Neue Generation |
|--------|-----------------|-----------------|
| PL6010 | 388 mm | 450 mm |
| PL7710 | 425 mm | 450 mm |
| PL3210 | 356 mm | Keine Änderung |
| PL1210 | 356 mm | Keine Änderung |

! Wenn Ihr alter Motor bereits ein Modell der neuen Generation war, können Sie den neuen Motor direkt einbauen. Andernfalls lesen Sie bitte den weiteren Verlauf dieser Anleitung.

BESCHREIBUNG

LIEFERUMFANG



| | | | |
|---|----------------|---|------------|
|  | Bohrmaschine |  | Holzhammer |
|  Ø5 | Metallbohrer |  | Maßband |
|  Ø6 | Gewindebohrer |  | Körner |
|  T4 | Inbusschlüssel | | |

INSTALLATION

! Ihr Motor ist ein Modell der älteren Generation. Bitte befolgen Sie die folgenden Anweisungen.

ÄNDERUNG DES MASTS

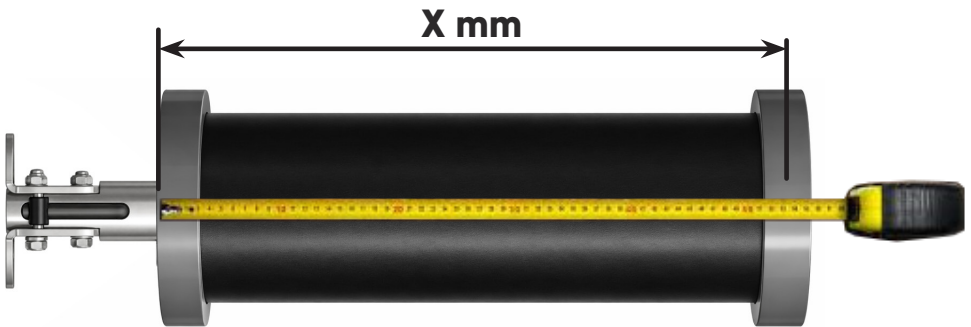

SCHRITT - 1

Markieren Sie mit einem Marker die neuen Bohrungen, die bei 435 mm vom Rand des Rohrs rundum anzubringen sind.

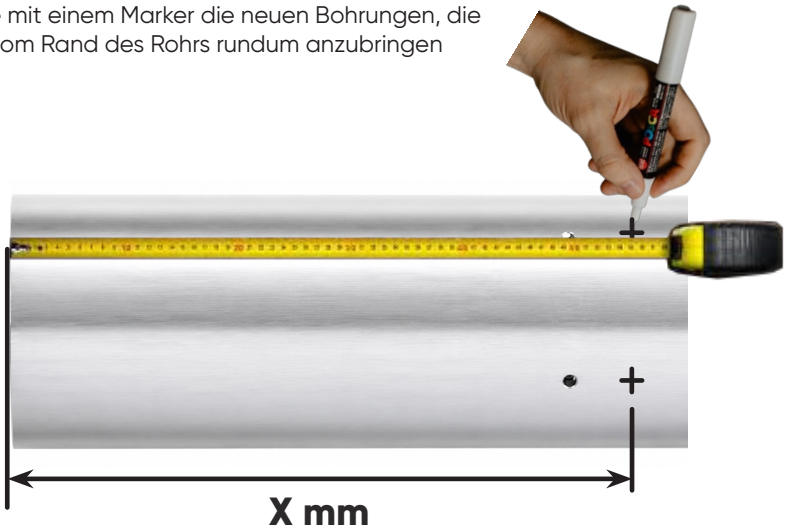

INSTALLATION

SCHRITT - 2



An der Markierung ankörnen.

SCHRITT - 3

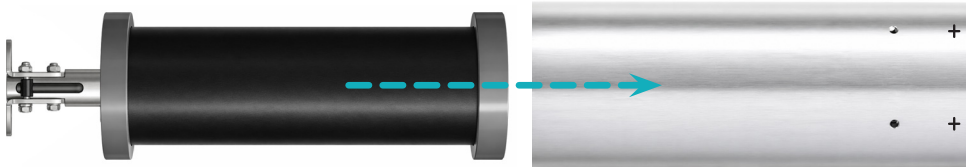

Den Motor in das Rohr einsetzen.



Die Kante des Motors muss mit der Kante des Rohrs übereinstimmen.

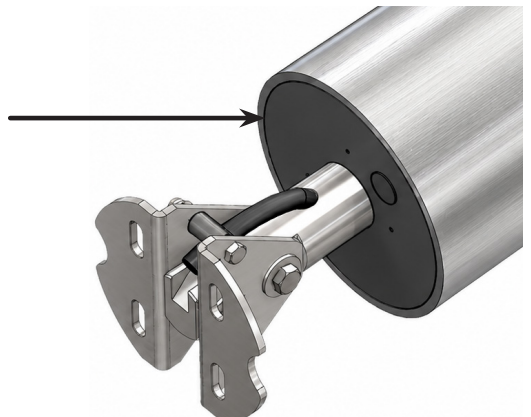

INSTALLATION

➤ SCHRITT - 4

Bohren Sie das Rohr und den Motor an den markierten Stellen mit einem Bohrer $\varnothing 5$ mm. Schneiden Sie anschließend nur in das Rohr mit einem Gewindebohrer $\varnothing 6$ ein Gewinde.

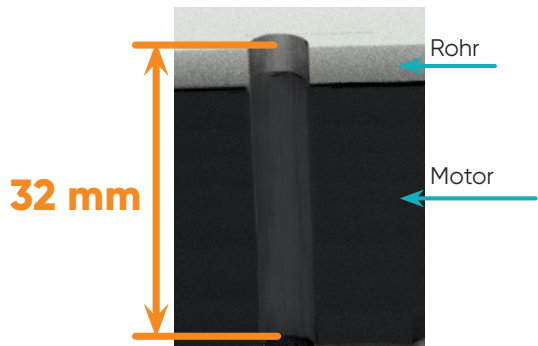

32 ±1 mm Bohrtiefe

35 mm maximale Bohrtiefe



! Achten Sie nach dem Bohren unbedingt darauf, weder den Mast noch den Motor zu bewegen.

INSTALLATION

SCHRITT - 5

Befestigen Sie den Motor mit den Schrauben und Unterlegscheiben am Rohr.



DEL SAS
ZA LA CROIX ROUGE
35530 BRÉCÉ - FRANCE

+33(0)9 70 72 5000 / INFO.FR@CF.GROUP

CACHET / STAMP / STEMPLET



une marque / A brand by / Eine marke



NOTICE ORIGINALE

/ 05 2026

A-DOTE03013

Revises sur www.cfgroup.fr